



Deploying Avaya Wireless DECT with IP Office

Release 12.2
Issue 21
August 2025

Notices

© 2026 Avaya LLC. All Rights Reserved.

You may, at your own risk, assemble a MyDocs collection solely for your own internal business purposes, which constitutes a modification to the original published version of the publications. Avaya shall not be responsible for any modifications, additions, or deletions to the original published version of publications. You agree to defend, indemnify and hold harmless Avaya, Avaya's agents, servants and employees against all claims, lawsuits, demands and judgments arising out of, or in connection with, your modifications, additions or deletions to the publications.

A single topic or a collection of topics may come from multiple Avaya publications. All of the content in your collection is subject to the legal notices and disclaimers in the publications from which you assembled the collection. For information on licenses and license types, trademarks, and regulatory statements, see the original publications from which you copied the topics in your collection.

Except where expressly stated by Avaya otherwise, no use should be made of materials provided by Avaya on this site. All content on this site and the publications provided by Avaya including the selection, arrangement and design of the content is owned by Avaya and/or its licensors and is protected by copyright and other intellectual property laws including the sui generis rights relating to the protection of databases. Avaya owns all right, title and interest to any modifications, additions or deletions to the content in the Avaya publications.

Notice

While reasonable efforts have been made to ensure that the information in this document is complete and accurate at the time of printing, Avaya assumes no liability for any errors. Avaya reserves the right to make changes and corrections to the information in this document without the obligation to notify any person or organization of such changes.

Documentation disclaimer

"Documentation" means information published in varying media which may include product information, subscription or service descriptions, operating instructions and performance specifications that are generally made available to users of products. Documentation does not include marketing materials. Avaya shall not be responsible for any modifications, additions, or deletions to the original published version of Documentation unless such modifications, additions, or deletions were performed by or on the express behalf of Avaya. End user agrees to indemnify and hold harmless Avaya, Avaya's agents, servants and employees against all claims, lawsuits, demands and judgments arising out of, or in connection with, subsequent modifications, additions or deletions to this documentation, to the extent made by End user.

Link disclaimer

Avaya is not responsible for the contents or reliability of any linked websites referenced within this site or Documentation provided by Avaya. Avaya is not responsible for the accuracy of any information, statement or content provided on these sites and does not necessarily endorse the products, services, or information described or offered within them. Avaya does not guarantee that these links will work all the time and has no control over the availability of the linked pages.

Warranty

Avaya provides a limited warranty on Avaya hardware and software. Please refer to your agreement with Avaya to establish the terms of the limited warranty. In addition, Avaya's standard warranty language as well as information regarding support for this product while under warranty is available to Avaya customers and other parties through the Avaya Support website: <https://support.avaya.com/helpcenter/getGenericDetails?detailId=C20091120112456651010> under the link "Warranty & Product Lifecycle" or such successor site as designated by Avaya. Please note that if the product(s) was purchased from an authorized Avaya channel partner outside of the United States and Canada, the warranty is provided by said Avaya Channel Partner and not by Avaya.

"Hosted Service" means an Avaya hosted service subscription that You acquire from either Avaya or an authorized Avaya Channel Partner (as applicable) and which is described further in Hosted SAS or other service description documentation regarding the applicable hosted service. If You purchase a Hosted Service subscription, the foregoing limited warranty may not apply but You may be entitled to support services in connection with the Hosted Service as described further in your service description documents for the applicable Hosted Service. Contact Avaya or Avaya Channel Partner (as applicable) for more information.

Hosted Service

THE FOLLOWING APPLIES ONLY IF YOU PURCHASE AN AVAYA HOSTED SERVICE SUBSCRIPTION FROM AVAYA OR AN AVAYA CHANNEL PARTNER (AS APPLICABLE). THE TERMS OF USE FOR HOSTED SERVICES ARE AVAILABLE ON THE AVAYA WEBSITE, [HTTPS://SUPPORT.AVAYA.COM/LICENSEINFO](https://support.avaya.com/licenseinfo) UNDER THE LINK "Avaya Terms of Use for Hosted Services" OR SUCH SUCCESSOR SITE AS DESIGNATED BY AVAYA, AND ARE APPLICABLE TO ANYONE WHO ACCESSES OR USES THE HOSTED SERVICE. BY ACCESSING OR USING THE HOSTED SERVICE, OR AUTHORIZING OTHERS TO DO SO, YOU, ON BEHALF OF YOURSELF AND THE ENTITY FOR WHOM YOU ARE DOING SO (HEREINAFTER REFERRED TO INTERCHANGEABLY AS "YOU" AND "END USER"), AGREE TO THE TERMS OF USE. IF YOU ARE ACCEPTING THE TERMS OF USE ON BEHALF A COMPANY OR OTHER LEGAL ENTITY, YOU REPRESENT THAT YOU HAVE THE AUTHORITY TO BIND SUCH ENTITY TO THESE

TERMS OF USE. IF YOU DO NOT HAVE SUCH AUTHORITY, OR IF YOU DO NOT WISH TO ACCEPT THESE TERMS OF USE, YOU MUST NOT ACCESS OR USE THE HOSTED SERVICE OR AUTHORIZE ANYONE TO ACCESS OR USE THE HOSTED SERVICE.

Licenses

The Global Software License Terms ("Software License Terms") are available on the following website <https://www.avaya.com/en/legal-license-terms/> or any successor site as designated by Avaya. These Software License Terms are applicable to anyone who installs, downloads, and/or uses Software and/or Documentation. By installing, downloading or using the Software, or authorizing others to do so, the end user agrees that the Software License Terms create a binding contract between them and Avaya. In case the end user is accepting these Software License Terms on behalf of a company or other legal entity, the end user represents that it has the authority to bind such entity to these Software License Terms.

Copyright

Except where expressly stated otherwise, no use should be made of materials on this site, the Documentation, Software, Hosted Service, or hardware provided by Avaya. All content on this site, the documentation, Hosted Service, and the product provided by Avaya including the selection, arrangement and design of the content is owned either by Avaya or its licensors and is protected by copyright and other intellectual property laws including the sui generis rights relating to the protection of databases. You may not modify, copy, reproduce, republish, upload, post, transmit or distribute in any way any content, in whole or in part, including any code and software unless expressly authorized by Avaya. Unauthorized reproduction, transmission, dissemination, storage, or use without the express written consent of Avaya can be a criminal, as well as a civil offense under the applicable law.

Virtualization

The following applies if the product is deployed on a virtual machine. Each product has its own ordering code and license types. Unless otherwise stated, each Instance of a product must be separately licensed and ordered. For example, if the end user customer or Avaya Channel Partner would like to install two Instances of the same type of products, then two products of that type must be ordered.

Third Party Components

The following applies only if the H.264 (AVC) codec is distributed with the product. THIS PRODUCT IS LICENSED UNDER THE AVC PATENT PORTFOLIO LICENSE FOR THE PERSONAL USE OF A CONSUMER OR OTHER USES IN WHICH IT DOES NOT RECEIVE REMUNERATION TO (i) ENCODE VIDEO IN COMPLIANCE WITH THE AVC STANDARD ("AVC VIDEO") AND/OR (ii) DECODE AVC VIDEO THAT WAS ENCODED BY A CONSUMER ENGAGED IN A PERSONAL ACTIVITY AND/OR WAS OBTAINED FROM A VIDEO PROVIDER LICENSED TO PROVIDE AVC VIDEO. NO LICENSE IS GRANTED OR SHALL BE IMPLIED FOR ANY OTHER USE. ADDITIONAL INFORMATION MAY BE OBTAINED FROM MPEG LA, L.L.C. SEE [HTTP://WWW.MPEGLA.COM](http://www.mpegla.com).

Service Provider

WITH RESPECT TO CODECS, IF THE AVAYA CHANNEL PARTNER IS HOSTING ANY PRODUCTS THAT USE OR EMBED THE H.264 CODEC OR H.265 CODEC, THE AVAYA CHANNEL PARTNER ACKNOWLEDGES AND AGREES THE AVAYA CHANNEL PARTNER IS RESPONSIBLE FOR ANY AND ALL RELATED FEES AND/OR ROYALTIES. THE H.264 (AVC) CODEC IS LICENSED UNDER THE AVC PATENT PORTFOLIO LICENSE FOR THE PERSONAL USE OF A CONSUMER OR OTHER USES IN WHICH IT DOES NOT RECEIVE REMUNERATION TO: (i) ENCODE VIDEO IN COMPLIANCE WITH THE AVC STANDARD ("AVC VIDEO") AND/OR (ii) DECODE AVC VIDEO THAT WAS ENCODED BY A CONSUMER ENGAGED IN A PERSONAL ACTIVITY AND/OR WAS OBTAINED FROM A VIDEO PROVIDER LICENSED TO PROVIDE AVC VIDEO. NO LICENSE IS GRANTED OR SHALL BE IMPLIED FOR ANY OTHER USE. ADDITIONAL INFORMATION FOR H.264 (AVC) AND H.265 (HEVC) CODECS MAY BE OBTAINED FROM MPEG LA, L.L.C. SEE [HTTP://WWW.MPEGLA.COM](http://www.mpegla.com).

Compliance with Laws

You acknowledge and agree that it is Your responsibility to comply with any applicable laws and regulations, including, but not limited to laws and regulations related to call recording, data privacy, intellectual property, trade secret, fraud, and music performance rights, in the country or territory where the Avaya product is used.

Preventing Toll Fraud

“Toll Fraud” is the unauthorized use of your telecommunications system by an unauthorized party (for example, a person who is not a corporate employee, agent, subcontractor, or is not working on your company's behalf). Be aware that there can be a risk of Toll Fraud associated with your system and that, if Toll Fraud occurs, it can result in substantial additional charges for your telecommunications services.

Avaya Toll Fraud intervention

If You suspect that You are being victimized by Toll Fraud and You need technical assistance or support, please contact your Avaya Sales Representative.

Security Vulnerabilities

Information about Avaya's security support policies can be found in the Security Policies and Support section of <https://support.avaya.com/security>.

Suspected Avaya product security vulnerabilities are handled per the Avaya Product Security Support Flow (<https://support.avaya.com/css/P8/documents/100161515>).

Trademarks

The trademarks, logos and service marks (“Marks”) displayed in this site, the Documentation, Hosted Service(s), and product(s) provided by Avaya are the registered or unregistered Marks of Avaya, its affiliates, its licensors, its suppliers, or other third parties. Users are not permitted to use such Marks without prior written consent from Avaya or such third party which may own the Mark. Nothing contained in this site, the Documentation, Hosted Service(s) and product(s) should be construed as granting, by implication, estoppel, or otherwise, any license or right in and to the Marks without the express written permission of Avaya or the applicable third party.

Avaya is a registered trademark of Avaya LLC.

All non-Avaya trademarks are the property of their respective owners.

Linux® is the registered trademark of Linus Torvalds in the U.S. and other countries.

Downloading Documentation

For the most current versions of Documentation, see the Avaya Support website: <https://support.avaya.com>, or such successor site as designated by Avaya.

Contact Avaya Support

See the Avaya Support website: <https://support.avaya.com> for Product or Cloud Service notices and articles, or to report a problem with your Avaya Product or Cloud Service. For a list of support telephone numbers and contact addresses, go to the Avaya Support website: <https://support.avaya.com> (or such successor site as designated by Avaya), scroll to the bottom of the page, and select Contact Avaya Support.

Contents

Part 1: Avaya Wireless DECT	11
Chapter 1: Avaya Wireless DECT	12
Avaya Wireless DECT System Components.....	12
What's New.....	14
Reset /Restart Switch.....	15
Chapter 2: Base Stations	17
Base Station Types.....	17
IP Base Stations.....	19
Digital Base Stations.....	20
Base Station Details.....	20
Base Station Status Lamps.....	22
IPBS1 Base Stations.....	22
IPBS2/IPBS3 Base Stations.....	22
Digital Base Station.....	23
Aerials.....	23
Chapter 3: IP DECT Digital Gateway (IPBL)	25
IP DECT Gateway Status Lamps.....	26
IP DECT Gateway Status Lamp.....	26
Base Station Port Lamps.....	26
LAN Port Lamps.....	27
Chapter 4: Phones	28
3720.....	29
3725.....	30
3730.....	31
3735.....	32
3745.....	33
3749.....	34
3755.....	35
3759.....	38
Chargers.....	41
Chapter 5: Avaya In-Building Wireless Server	43
AIWS1.....	43
AIWS1 Status Lamp.....	45
AIWS2.....	46
Front Panel.....	48
Rear Panel.....	49
Status LED.....	49
Power LED.....	49
Mode LED.....	50

Part 2: Performing a Site Survey	51
Chapter 6: Site Survey and Planning	52
Factors to Consider.....	52
Base Station Signal Strength.....	54
Handover.....	55
Base Station Synchronization.....	56
Advanced Scenario: Separated Locations.....	56
Performing a Survey.....	57
Site Survey Mode.....	57
Part 3: Doing a Provisioned Installation	59
Chapter 7: Provisioned Installation	60
IP Office Installation Requirements.....	61
IP Base Station Installation Requirements.....	61
Phone Subscription Requirements.....	62
Unpacking the DECT Software.....	63
Device Management.....	64
Chapter 8: Configuring IP Office	65
Configuring Security Settings.....	65
IP Office System VoIP Codecs.....	68
Creating IP DECT Lines.....	68
Enabling Subscription.....	70
Adding Licenses.....	72
Reserving Licenses.....	72
Configuring a Source Number.....	73
Chapter 9: Master Base Station Setup	75
Defaulting the Base Station.....	76
Accessing the Base Station Configuration.....	76
Setting the Base Station IP Address.....	78
Configuring a Virtual Local Area Network (VLAN).....	79
Configuring a VLAN.....	79
Updating the Base Station Software.....	81
Selecting Administration Mode.....	83
Selecting Master Mode.....	84
Setting the DECT Password.....	85
Setting the Time Zone.....	86
Enabling Provisioning.....	87
Enabling HTTPS and Security Certificates in the Web Interface.....	89
Adding Radio Connections.....	90
Phonebook Integration.....	91
Performing an RFP Scan.....	91
Entering the PARI.....	92
Configuring Air Sync.....	93

Advanced Scenario: Separated Locations.....	93
Configuring Air Sync in Separated Locations.....	94
Chapter 10: IP Slave Base Station Setup.....	96
Defaulting the Base Station.....	96
Accessing the Base Station Configuration.....	97
Setting the Base Station IP Address.....	98
Updating the Base Station Software.....	99
Setting a Base Station to Slave Mode.....	101
Registering the Slave Base Station.....	103
Chapter 11: Base Station Mounting.....	105
Mounting a Base Station using a Wallmount.....	105
Mounting a Base Station on a Column/Pillar.....	107
Chapter 12: Subscribing Phones	108
Preconfigured Phone Subscription.....	108
Auto-Create Phone Subscription.....	109
Allowing Subscription.....	109
Enabling IP Office Subscription.....	110
Master Base Station.....	111
Manually Creating Extensions.....	112
Subscribing a Phone.....	113
3700 Series Phones.....	113
Auto-Create Subscription Mode.....	116
Preconfigured Subscription Mode.....	116
3701/3711 Phones.....	116
Upgrading Phones.....	117
Installing Windows Device Manager to Upgrade Phones.....	117
Starting Windows Device Manager.....	120
Upgrading Phone Software.....	120
Displaying Subscribed Users.....	122
Using the Master Base Station.....	122
Using IP Office System Status.....	123
Unsubscribing Phones.....	123
Disabling Subscription.....	124
Part 4: Avaya Wireless DECT Resilience.....	125
Chapter 13: DECT Resilience.....	126
Viewing and Controlling Resilience.....	126
Chapter 14: Configuring Base Station Mirroring.....	128
Configuring the IP Office.....	128
Configuring the Mirrored Base Stations.....	129
Activating the Master Base Station.....	129
Chapter 15: Configuring Switch Resilience.....	131
Provisioned Base Station Configuration.....	131

Non-Provisioned Base Station Configuration.....	132
IP Office Configuration for Switch Resilience.....	133
IP Office Line Configuration for DECT Resilience.....	134
Part 5: Base Station Location Information.....	135
Chapter 16: Using IP Office Locations with Avaya Wireless DECT Base Stations...	136
Enabling Base Station Location Support.....	136
Setting the Base Station Locations.....	137
Importing Base Station Location IDs from a CSV File.....	137
Part 6: Digital Gateway Installation.....	139
Chapter 17: IP DECT Gateway Installation.....	140
IP DECT Gateway Installation Summary.....	140
Digital Base Station Power Consumption.....	141
Installing the Digital Base Stations.....	142
Mounting.....	143
Mounting a Base Station using a Wallmount.....	143
Mounting a Base Station on a Column/Pillar.....	144
Part 7: IP Office User Phone Features.....	146
Chapter 18: IP Office User Features.....	147
Idle Display.....	147
Status Indicators.....	148
Call Services.....	149
In Call Options.....	151
Call Waiting Options.....	152
Part 8: Device Management.....	154
Chapter 19: Device Management.....	155
Starting AIWS Device Manager.....	155
Loading Parameter Definition Files.....	156
Loading Phone Templates into Device Manager.....	158
Applying Templates to Phones.....	160
Editing Templates.....	162
Chapter 20: Upgrading Phone Software.....	165
Installing Windows Device Manager to Upgrade Phones.....	165
Starting Windows Device Manager.....	168
Upgrading Phone Software.....	168
Part 9: AIWS Installation.....	171
Chapter 21: AIWS Installation.....	172
Pre-Requisites.....	173
Parts Required.....	173
Information.....	173
Tools.....	174
Removing the AIWS Cover.....	174

Image Installation Mode.....	176
Connecting the RTC Battery.....	177
Connecting Cables to an AIWS.....	177
Accessing the AIWS Interface.....	178
Running the Setup Wizard.....	179
Enabling Base Station/AIWS Connection.....	186
Configuring the AIWS DECT Connection (Master Only).....	186
Enabling Status Log (Master and Slave).....	187
Upgrading the AIWS Firmware.....	188
Switching Off the AIWS.....	194
Mounting the AIWS on a Wall.....	194
Replacing the AIWS Cover.....	195
Chapter 22: Installing an AIWS2	197
Browsing to the AIWS2.....	197
Using the Network Connection.....	197
Using the USB Management Connection.....	198
Running the Setup Wizard.....	198
Enabling Base Station/AIWS Connection.....	205
Configuring the AIWS DECT Connection (Master Only).....	205
Enabling Status Log (Master and Slave).....	206
Upgrading the AIWS Firmware.....	207
Upgrading the AIWS2 Software	208
Switching Software.....	208
Part 10: Non-Provisioned Installation	210
Chapter 23: Non-Provisioned Installation	211
IP Office Installation Requirements.....	211
IP Base Station Installation Requirements.....	212
Phone Subscription Requirements.....	213
Unpacking the DECT Software.....	214
Chapter 24: IP DECT Line Setup	216
Adding Licenses.....	218
Reserving Licenses.....	218
Chapter 25: Configuring the Master Base Station	220
Pre-Requisites.....	221
Information.....	221
Parts Required.....	221
Tools.....	222
Defaulting the Base Station.....	222
Accessing the Base Station Configuration.....	223
Updating the Base Station Firmware.....	224
Setting the Base Station IP Address.....	227
Configuring a Virtual Local Area Network (VLAN).....	228

Configuring a VLAN.....	228
Setting the Time Source.....	230
QoS/ToS Settings.....	231
Setting the Base Station as the Master.....	231
Enabling Supplementary Services.....	233
Setting the PBX Switch Mode.....	234
Configuring IP Trunks	235
Entering the Radio Settings.....	235
Performing an RFP Scan.....	236
Entering the PARI.....	237
Entering the SARI/PARK.....	238
Configuring Air Sync.....	238
Advanced Scenario: Separated Locations.....	239
Integrating the IP Office Directory	240
Resetting a Master Base Station.....	241
Checking Master Base Station Radio.....	242
Chapter 26: Configuring IP Slave Base Stations	243
Pre-Requisites.....	243
Information.....	243
Parts Required.....	244
Defaulting the Base Station.....	245
Accessing Base Station Configuration.....	246
Updating Base Station Firmware.....	247
Setting a Base Station IP Address.....	249
Setting a Base Station to Slave Mode.....	250
Resetting a Base Station.....	252
Chapter 27: Checking a Base Station Signaling Status.....	253
Master Base Station.....	253
Slave Base Station.....	254
Chapter 28: Mounting a Base Station	255
Mounting a Base Station using a Wallmount.....	255
Mounting a Base Station on a Column/Pillar.....	257
Chapter 29: Phone Subscription.....	258
Pre-Requisites.....	258
Information.....	258
Tools.....	259
Allowing Subscription.....	259
Enabling IP Office Subscription.....	259
Master Base Station.....	260
Creating User Entries.....	261
Subscribing a Phone.....	263
3701/3711 Phone Subscription.....	265
Completing Anonymous Login.....	266

Disabling Subscription.....	267
Part 11: Further Help	268
Chapter 30: Additional Help and Documentation	269
Additional Manuals and User Guides.....	269
Getting Help.....	269
Finding an Avaya Business Partner.....	270
Additional IP Office resources.....	270
Training.....	271

Part 1: Avaya Wireless DECT

Chapter 1: Avaya Wireless DECT

Avaya Avaya Wireless DECT is a Digital Enhanced Cordless Telecommunications system connecting multiple base stations using an IP LAN to provide an IP based cordless telephony and messaging system. This installation manual covers the installation of Avaya Wireless DECT systems using the firmware supported by IP Office Release 12.2.

This document is a basic manual covering the most common install scenarios for Avaya Wireless DECT with an IP Office system. For more advanced options and complex install scenarios, refer to the full set of Avaya Wireless DECT manuals.

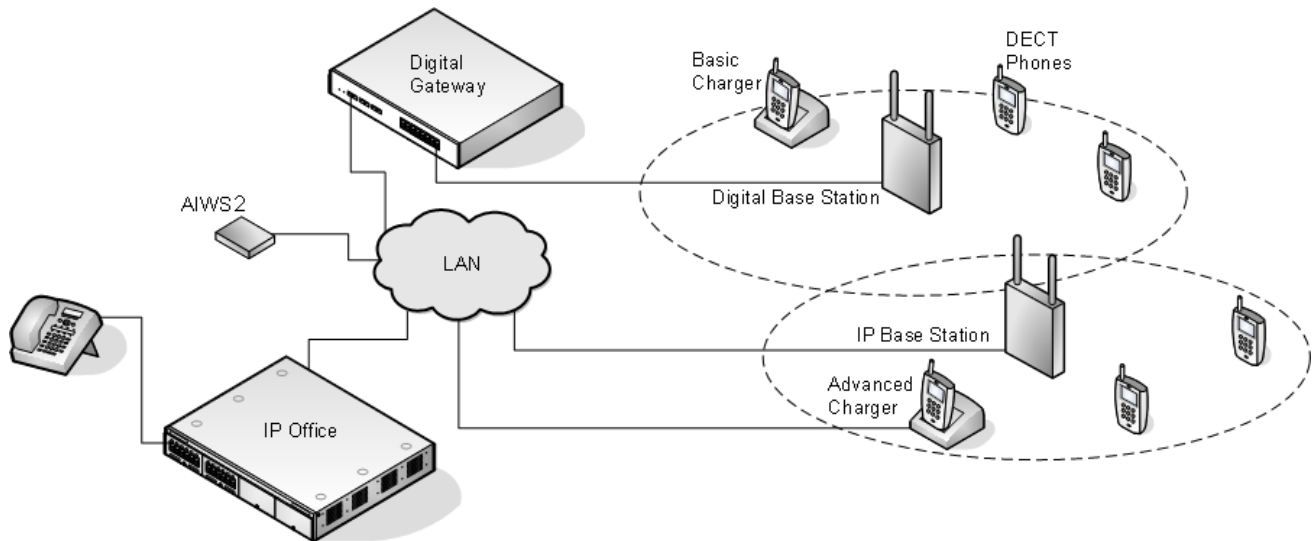

Related links

[Avaya Wireless DECT System Components](#) on page 12

[What's New](#) on page 14

[Reset /Restart Switch](#) on page 15

Avaya Wireless DECT System Components

The following table summarizes the components used in a Avaya Wireless DECT system.

Component	Details
Base Stations	
Up to 1000 base stations are supported. This can be a mix of IP and digital base stations, though the digital base stations are limited to a maximum of 128.	
IP Base Stations:	<p>These base stations connect to the IP Office system through the customer's IP network.</p> <ul style="list-style-type: none"> • Standard IP DECT Base Station (IPBS) on page 17 Standard stations have eight channels used for speech and messaging, and one channel which is reserved for broadcast messages. During installation one is configured as the master base station, to which the other base stations synchronize as slave base stations. Each base station can host up to 8 simultaneous phone conversations in its coverage area. • Compact Base Stations: Compact base stations are identical to standard base stations but only support up to 4 simultaneous calls.
Digital Base Stations	<p>These base stations connect to an IP DECT Gateway (see IP DECT Digital Gateway (IPBL) on page 25) using traditional 4-wire telephone cabling. The gateway then connects to the IP Office system through the customer's IP network.</p> <ul style="list-style-type: none"> • Up to 8 IP DECT Gateway units are supported per IP Office. • Up to 16 digital base stations can be connected to each IP DECT Gateway, for a maximum of 128 digital base stations. • Digital base stations are available in variants with internal and external aerials. There is no digital variant of the Compact Base Station base station.
IP DECT Digital Gateway	<p>The IP DECT Gateway allows Digital base stations to be connected to the DECT system (see Digital Base Stations on page 20). An IPBL is intended to be used only if Digital base stations will be deployed in an IP-DECT system. Up to 16 digital base stations can be connected to each gateway, using traditional 4-wire telephony cabling.</p> <p>The gateway itself connects to the IP Office and other IP based elements of the system through via the IP LAN. See IP DECT Digital Gateway (IPBL) on page 25.</p>
Phones	
On Linux-based solutions, up to 1500 DECT phones are supported (subject to the server platform/solution supporting that number of extensions, refer to the Avaya IP Office™ Platform Guidelines: Capacity). IP500 V2 systems support up to 384 extension.	
3700 Series Phones	The currently available Avaya 3700 Series phones supported. See Phones on page 28. Other DECT phones are supported but only for basic telephony using the DECT GAP and DECT CAP standards.
Chargers	A number of different types of charger exist for 3700 Series phones. See Chargers on page 41. Some of the chargers are advanced chargers which allow the phone docked with the charger to be accessed using the Device Manager application (browser access via the AIWS unit and charger LAN port or WinPDM application via the USB port).
IP Office System	

Table continues...

Component	Details
IP Office	Avaya Wireless DECT is supported on IP Office systems running in any mode other than IP Office Basic Edition mode.
VCM Channels	IP500 V2/V2A systems require base cards that provide VCM channels to support VoIP telephony.
Licenses	Each phone subscribed via the Avaya Wireless DECT systems requires an Avaya IP Endpoint license in the IP Office configuration.
Other Components	
Configuration Tools	<p>The tools and applications for Avaya Wireless DECT are included as part of the IP Office Manager installer.</p> <ul style="list-style-type: none"> This includes the appropriate base station and phone firmware for their operation with the IP Office release. IP DECT firmware is also downloadable from the Avaya Support site.
AIWS	<p>This unit allows SMS messaging between handsets, handset configuration and directory integration. See Avaya In-Building Wireless Server (AIWS) on page 43.</p> <ul style="list-style-type: none"> Without an AIWS, handsets can only be upgraded and configured when in an advanced charger. Directory integration can be done by the master base station but without SMS support. If both SMS and directory integration are required, an AIWS unit must be used.

Related links

[Avaya Wireless DECT](#) on page 12

What's New

The following changes have been made for Avaya Wireless DECT support:

IP Office Release 12.2

- **Maximum DECT IP base station capacity increased**

With Avaya Wireless DECT R5, the maximum IP base station capacity has increased from 256 to 1000.

- **Avaya Wireless DECT R5 firmware**

The Avaya Wireless DECT R5 firmware is now included as part of the IP Office administration software installation package.

IP Office Release 12.1 SP1

- **Support for R5 firmware**

IP Office supports Avaya Wireless DECT running R5 firmware.

- **Maximum DECT extension capacity increased on Linux-based systems**

With Avaya Wireless DECT R5, the maximum DECT extension capacity on a Linux-based IP Office primary and secondary servers has increased from 750 to 1500.

- The overall extension capacity, including DECT and non-DECT extensions, must still remain within the extension capacity of the individual IP Office system and the IP Office solution.

IP Office Release 11.1.3 SP1

- **3755/3759 Phone Support**

IP Office supports these new models of 3700 Series phones.

IP Office Release 11.1 FP2 SP2

- **Base Station Location Information**

Base stations can be configured with location ID's that match locations configured on the IP Office system. This allows the appropriate location emergency ARS and address settings to be applied when a DECT extensions makes an emergency call. See [Using IP Office Locations with Avaya Wireless DECT Base Stations](#) on page 136.

IP Office Release 11.0

- **Maximum DECT Extension Capacity Increased on Linux-Based Systems**

For Avaya Wireless DECT systems linked to a Linux-based server, the maximum Avaya Wireless DECT extension capacity has increased from 384 to 750. The maximum limit on IP500 V2 systems (including Server Edition expansions) remains at 384.

- **Maximum Base Stations Capacity Increased**

The maximum number of base stations supported in a Avaya Wireless DECT system connected to IP Office has been increased from 128 to 256.

- **Compact Base Station Capacity Limitations Removed**

The previous maximum limit of 5 compact base stations has been removed. Any mix of compact and non-compact base stations is supported up to the overall base station limit above. Note that base station mirroring between a compact and non-compact base stations is still not supported.

Related links

[Avaya Wireless DECT](#) on page 12

Reset /Restart Switch

The base stations (all types), IP DECT Gateway and AIWS2 all include a reset switch. To press it requires a fine point. How long the switch is depressed affects the type of reset.

Action	Duration	Effect
Short press	Less than 1 second	Restart

Table continues...

Action	Duration	Effect
Medium press	Approximately 3 seconds	Restart in TFTP mode. This mode is intended for development only.
Long press	Approximately 10 seconds	Factory reset. All configuration parameters will be set to default values.

Related links

[Avaya Wireless DECT](#) on page 12

Chapter 2: Base Stations

Avaya Wireless DECT supports several base station variants. They differ in aerial connection, the number of simultaneous calls supported and how they connect to the DECT system. Normally, during installation, one of the base stations is configured as the master base station for the whole Avaya Wireless DECT system. Remaining base stations are then configured as slave base stations.

The availability of particular base stations variants depends on the country of operation.

Base Station Types

The following types of base station are available for use in a Avaya Wireless DECT system. They are available as IP and or digital versions. Each base station includes a detachable bracket for wall mounting or column mounting of the base station. The bracket allows the base station to be removed for maintenance. The same brackets are used for all base station types , allowing for quick interchange of base stations.

- **Internal Aerial Base Stations**

These standard base stations have two internal aerials which cannot be adjusted. The aerials produce a directional pattern of radio coverage. The base station supports up to eight simultaneous calls. This type of base station is available in both IP (IPBS1 and IPBS2/IPBS3) base station and digital base station versions.



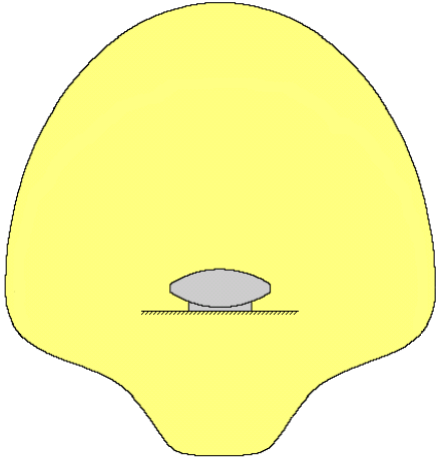

- **Compact Base Station**

This type of base station, available for IPBS1 and IPBS2/IPBS3, is physically similar to other base stations with internal aerials but only supports 4 simultaneous calls. Compact Base Stations are only supported if all other base stations are running firmware version 5.0.11 or later.

- **External Aerial Base Stations**

These base stations have two external aerials. These aerials produce an even pattern of radio coverage. The base station supports up to eight simultaneous calls. The aerials can be disconnected and replaced by a various other types of aerials if different radio coverage patterns and range is required. This type of base station is available in both IP (IPBS1 and IPBS2/IPBS3) base station and digital base station versions. Note that the placement of the aerial connectors differs between IPBS1 and IPBS2/IPBS3.

This type of base station is not supported in North America.

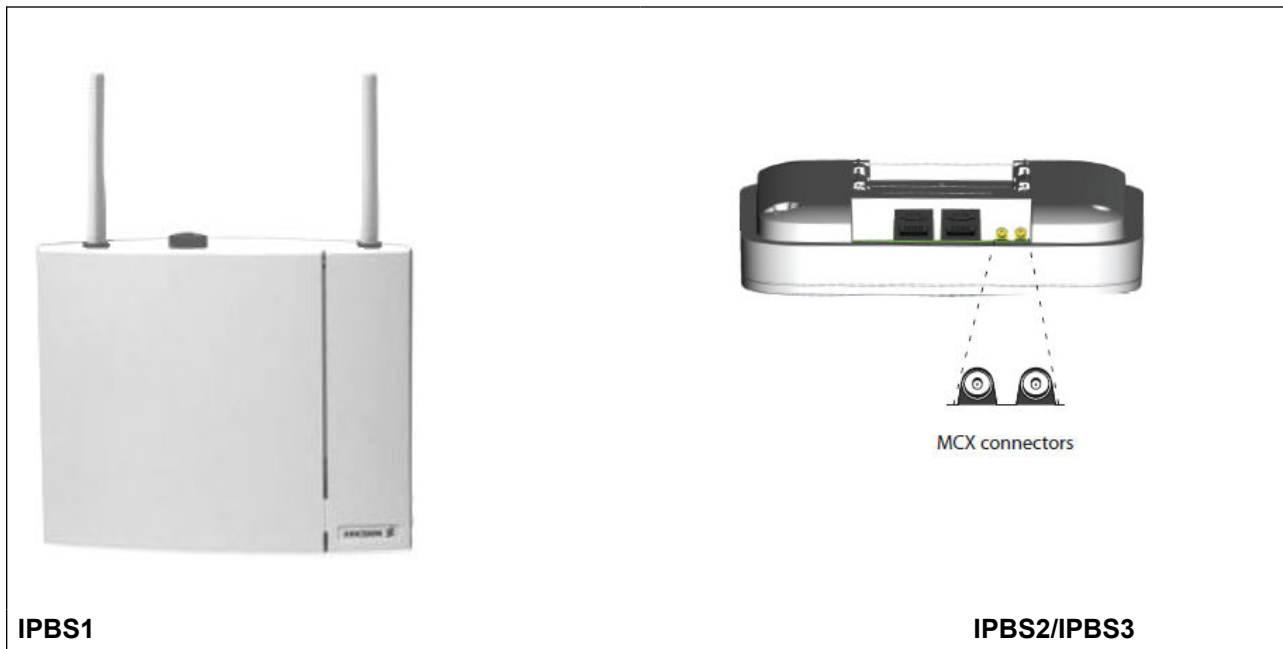

IPBS1

IPBS2/IPBS3

IPBS1

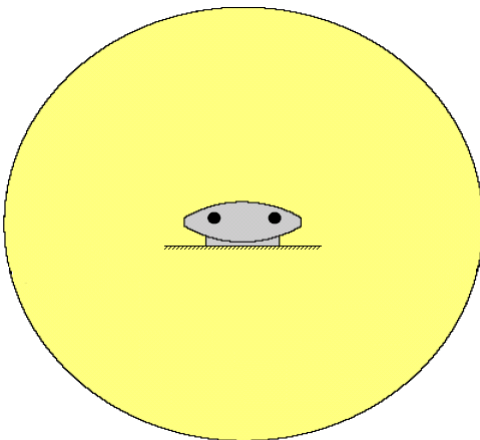

IP Base Stations

IP base stations are supplied with a mounting bracket and a 1.2 metre (4 foot) LAN cable. Power the base station using IEEE 802.3af Power over Ethernet (PoE). Alternatively, the base station might use an external power supply (Optional regional dependent part from Avaya) provided that an outlet socket exists within 8 metres (26 feet) cable distance.

The original IPBS1 versions of these base stations have been replaced by IPBS2/IPBS3 versions. The two types are functionally the same and can be mixed in the same installation. Avaya will continue to offer the same versions of the IPBS2/IPBS3 as were offered for the IPBS1

! Important:

For IP Office Release 10.0 and higher, IPBS1 base stations are only supported as slave radio base stations. IPBS1 base stations are no longer supported in other roles, for example as master base stations. For systems being upgraded, any existing IPBS1 base station being used in a non-slave role must first be replaced in that role with an IPBS2/IPBS3 or IPBL1.

The IPBS2/IPBS3 products are fully interoperable with IPBS1 products and the IP DECT Gateway solution.

Digital Base Stations

You can connect digital base stations to the DECT system using an IP DECT Gateway (see [IP DECT Digital Gateway \(IPBL\)](#) on page 25). These base stations are physically similar to the IPBS1 base stations, using the same casings and mounting brackets, but connect directly to an IP DECT Gateway using traditional 4-wire telephone cabling.

Digital base stations are available in variants with internal and external aerials. There is no digital variant of the Compact Base Station base station.

- Digital Base Station with internal antennas for European Union, Switzerland, Iceland, Liechtenstein, Norway and Russia.
- Digital Base Station with external antennas for European Union, Switzerland, Iceland, Norway and Russia.
- Digital Base Station with internal antennas for US and Canada.

Digital base stations can be powered either direct from the IP DECT Gateway or using separate power adapters for each base station. The number of base stations that the IP DECT Gateway can power depends on the cable distance to each base station and the type of cable used. A table indicating the base station power consumption can be found under [Digital Base Station Power Consumption](#) on page 141. You can use the table to calculate whether the IP DECT Gateway can directly power the digital base stations. In cases where the IP DECT Gateway cannot directly power all the digital base stations, some of the base stations will need a separate power connection.

Base Station Details

Feature		Details
DECT Frequencies	Brazil	1910-1920 MHz frequencies.
	Latin America	1910-1930 MHz frequencies.

Table continues...

Feature	Details	
	North America	1920-1930 MHz frequencies.
	Rest of World	1880-1900 MHz frequencies.
Physical	Dimensions (Height x Width x Depth)	165 x 200 x 56 mm (including mounting bracket). Add 95mm height for external aerials.
	Weight	450g
	Material	ABS moulded plastic
	Colour	Beige
	External connectors	2 x RJ45, 1 x RJ12
	Power (IP Base Stations)	Input
Operating voltage		21 to 56 V dc.
Power consumption		Typical 4W, maximum 5W.
Power over Ethernet		PoE Class 2 (7W).
Network (IP Base Stations)	Ethernet	10/100baseT
	Voice over IP	H.323 XMobile incl. QSig/DSS1.
	Voice Encoding	G.711 A-law / Mu-law (64kbps) G.723.1 (5.3 kbps) G.729A and AB (16 kbps) * Note: Avaya recommends against using Audio codec G.723.1 for mixed installations containing both IPBS1 and IPBS2/IPBS3.
Radio	RF output power EU	Between 23 dBm and 28 dBm (with internal antenna) Between 20 dBm and 25 dBm (with external antenna)
	RF output power US	Between 17 dBm and 21,6 dBm (with internal antenna)
Environmental	Operating temperature	-10°C to +55°C
	Storage temperature	-40°C to +70°C
	Relative operating humidity	15 to 90%, non condensing
	Relative storage humidity	5 to 95%, non condensing
	Immunity to electromagnetic fields	3V/m (EN61000-4-3)
	Immunity to ESD	4 kV contact discharge and 8 kV air discharge (EN61000-4-2)

Base Station Status Lamps

IPBS1 Base Stations

Each IPBS1 base station has two LED lamps.

LED	Color	Description
LED 2 - Activity	Off	Idle, no calls in progress.
	Green	Calls in progress.
	Green Flashing	Maximum calls in progress.
	Amber*	Air synchronization insufficient and calls in progress.
	Amber Flashing*	Air synchronization insufficient and no calls in progress.
	Amber Slow Flashing*	Air synchronization insufficient and maximum calls in progress.
	Red Flashing	No air synchronization. Searching for synchronization signal.
	Red Fast Flashing	Download of RFP software in progress.
LED 1 - Status This is the lower LED on the bottom edge of the base station.	Green	Operational
	Amber	TFTP Mode (<i>not used</i>).
	Amber Fast Flashing	Firmware download in progress.
	Alternating Red/Green	No Ethernet connection.
 Note:	* All amber statuses are warnings that Air synchronization, although still adequate, is fading and might be lost. A flashing red indicates lost Air synchronization.	

IPBS2/IPBS3 Base Stations

IPBS2/IPBS3 base stations have one LED to indicate status.

LED	Description
Blue On	Idle, no calls in progress.
Blue Fast Flash	Starting up or searching for air synchronization.
Blue On - Regular Blink	Calls in progress.
Blue On - Red Blink	Maximum calls in progress.
Blue Slow Flash	Firmware download in progress.
Yellow Fast Flash	IPBS2/IPBS3 is in mini firmware mode.
Yellow On	TFTP Mode (<i>not used</i>).

Table continues...

LED	Description
Red Fast Flash	No Ethernet connection.
Red On	Hardware error.
Blue On - Yellow Blink	The IPBS2/IPBS3 is in deployment mode and has air synchronization.
Red On - Yellow Blink	The IPBS2/IPBS3 is in deployment mode and has no air synchronization.
Blue Slow Flash/Yellow Flash	The IPBS2/IPBS3 is in deployment mode and does not have adequate air synchronization.
Green	Reset button depressed.

Digital Base Station

Digital base stations have two LED lamps.

LED	Color	Description
LED 2 - Activity	Off	Idle, no calls in progress.
	Green	Calls in progress.
	Green Flashing	Maximum calls in progress.
	Amber	Base station OK but not operational (self-test, no communication with IP DECT Gateway).
	Amber Flashing	Software download in progress.
LED 1 - Status This is the lower LED on the bottom edge of the base station.	Green	Operational
	—	—
	—	—

Aerials

The following aerials can be used to replace the supplied aerials on a base station with external aerials. These aerials have leads to allow for optimal positioning.

*** Note:**

These optional aerials are not supported in North America.

- **Omni-Directional Single Aerial**

A pair of these aerials can be used to approximately double the base station radio coverage, ie. up to 600 metres (2000 feet) omni-directional coverage.



- **Directional Dual Aerial**

This aerial gives directional coverage up to 750 metres (2500 feet). Only one aerial unit is required for connection to the base station.

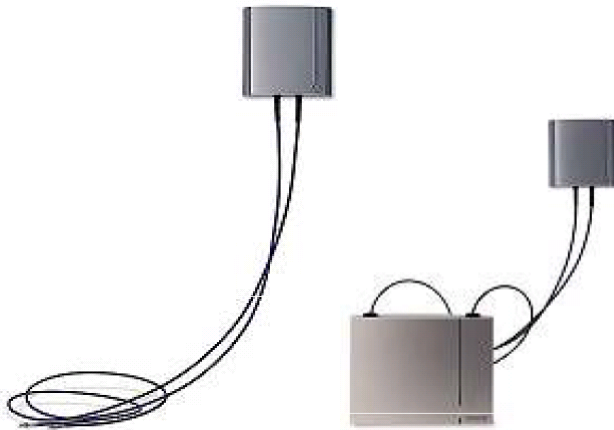

- **Directional Single Antenna**

A pair of these aerials can be used to give directional coverage up to 1000 metres (3300 feet). They must be mounted facing the same direction and approximately 1 metre (3 feet) apart. To achieve maximum coverage, the aerial should be mounted between 4 to 8 metres (13 to 26 feet) above area being covered.



Chapter 3: IP DECT Digital Gateway (IPBL)

The IP DECT Gateway allows digital base stations to be connected to the DECT system. Up to 16 digital base stations can be connected to a gateway, using traditional 4-wire telephony cabling. The gateway itself connects to the IP Office and other IP based elements of the system via the IP LAN.

Though the gateway does not support telephone calls without digital base stations connected, it can be configured to act as the master base station for the whole DECT system. It is possible for the gateway to act as a master even in a system that has a mix of IP and digital base stations.



The IP DECT Gateway provides the following features:

- Up to 8 IP DECT Gateway units are supported per IP Office.
- Up to 16 digital base stations can be connected to each IP DECT Gateway, for a maximum of 128 digital base stations.
- Synchronization of attached digital base stations via UPN cables (including automatic cable delay measurement).
- Over-the air synchronization master for IP base stations. Master sync or backup sync functionality can reside in the gateway appliance. It cannot be slave sync.
- Seamless roaming and handover, also with IP base station on same site.
- The IP DECT Gateway can act as the master base station for the DECT system. This does not affect the count of actual base stations (IP and or digital) allowed.
- Remote configuration and software upgrade of IP DECT Gateway appliance (web-based).
- Remote automatic update of digital base stations connected to the IP DECT Gateway.
- Configuration option for reuse of Avaya UPN repeaters. This means a configuration option for each base station port to disable the automatic cable delay measurement and allow to manually set a cable delay value for that specific port.
- Remote power feeding of digital base stations via UPN ports. The maximum cable length between the IP DECT Gateway and each digital base station should not exceed 1500 meters. The length and type of cable used affects the power consumption of the base station. If the total power capacity of the IP DECT Gateway is exceeded, additional digital base stations will require their own power support connection.

- The IPBL has eight channels for each RFP used for speech, message and alarm. The IPBL also has two channels which are reserved for messaging and alarm. In total, the IPBL has 40 speech channels.

Note: The IP DECT Gateway does not support call handover when the digital base station used for that call is reset or unplugged. This means that calls lost on one digital base station will not transfer to another digital base station.

Related links

[IP DECT Gateway Status Lamps](#) on page 26

IP DECT Gateway Status Lamps

Related links

[IP DECT Digital Gateway \(IPBL\)](#) on page 25

[IP DECT Gateway Status Lamp](#) on page 26

[Base Station Port Lamps](#) on page 26

[LAN Port Lamps](#) on page 27

IP DECT Gateway Status Lamp

This LED is located at the left-hand end of the front panel of the IP DECT Gateway.

LED	Description
Off	No power.
Green slow flash	Reset switch pressed.
Green fast flash	Firmware update in progress or config cleared after reset.
Green on	OK.
Red on	Error.
Amber on	TFTP mode.

Related links

[IP DECT Gateway Status Lamps](#) on page 26

Base Station Port Lamps

Each base station port has a left-hand and right-hand LED. These are used as follows:

Left-hand LED		Right-hand LED	
LED	Description	LED	Description
Off	No link to base station.	Off	No calls in progress.
On	Linked and base station operational.	On	Calls in progress.
Flashing	Linked but base station not operational.	Flashing	Maximum calls in progress.

Related links

[IP DECT Gateway Status Lamps](#) on page 26

LAN Port Lamps

Each LAN port has a left-hand and right-hand LED. These are used as follows:

Left-hand LED		Right-hand LED	
LED	Description	LED	Description
Off	No link or Ethernet connection.	Off	No connection or 10Mbps connection.
On	No network activity.	On	100Mbps connection
Flashing	Network activity.	—	—

Related links

[IP DECT Gateway Status Lamps](#) on page 26

Chapter 4: Phones

Avaya Wireless DECT supports a range of Avaya 3700 Series phones.

Related links

[3720](#) on page 29

[3725](#) on page 30

[3730](#) on page 31

[3735](#) on page 32

[3745](#) on page 33

[3749](#) on page 34

[3755](#) on page 35

[3759](#) on page 38

[Chargers](#) on page 41

3720

Avaya 3720	Features	
	<ul style="list-style-type: none"> • High quality voice DECT phone, GAP/CAP compliant. • Easy access to PBX services. • Voicemail including message icon. • Manual and automatic keypad lock. • Local directory: 250 entries. • Central directory from the IP Office. 	
	Dimensions	133 x 53 x 24mm
	Weight	115g
	Battery Type	600 mAh, Lithium 3.7V. Charge time 4 hours.
	Speech Time	> 16 hours.
	Standby Time	> 160 hours.

- For systems installed using IP Office provisioning, the language used is set by the IP Office system or user language setting.
- An additional language file can be uploaded to a phone.

Related links

[Phones](#) on page 28

3725

Avaya 3725	Features	
	<ul style="list-style-type: none"> • As per 3720 plus: • Site Survey tool. • Cleanable, IP 44. • Option: Bluetooth. • 19 Languages Czech, Danish, Dutch, English, Finnish, French, German, Greek, Hungarian, Italian, Norwegian, Polish, Portuguese (Brazilian), Portuguese, Russian, Slovakian, Spanish, Swedish and Turkish. • SMS Message length up to 160 characters. 30 received/sent messages. Requires AIWS. 	
	Dimensions	134 x 53 x 26mm
	Weight	130g
	BatteryType	930 mAh, Li-Pol 3.7V. Charge time 4 hours.
	Speech Time	> 20 hours (13h with Bluetooth option)
Standby Time	> 120 hours.	

- For systems installed using IP Office provisioning, the language used is set by the IP Office system or user language setting.
- An additional language file can be uploaded to a phone.

Related links

[Phones](#) on page 28

3730

Avaya 3730	Features	
	<ul style="list-style-type: none"> • High quality voice DECT phone, GAP/CAP compliant • Easy access to PBX services • Voicemail including message icon. • Manual and automatic keypad lock • Local directory: 250 entries. • Central directory from the IP Office. • Call list with the 25 last calls • Vibrator • Loudspeaker/hands free • Central Management and software download • Headset socket (3.5mm). • 19 Languages Czech, Danish, Dutch, English, Finnish, French, German, Greek, Hungarian, Italian, Norwegian, Polish, Portuguese (Brazilian), Portuguese, Russian, Slovakian, Spanish, Swedish and Turkish. • Color display (1.8", 128 x 160 pixels). 	
	Dimensions	136 x 53 x 21mm
	Weight	115g
	Battery Type	600 mAh, Lithium 3.7V. Charge time 4 hours.
	Speech Time	> 16 hours.
	Standby Time	> 160 hours.

- For systems installed using IP Office provisioning, the language used is set by the IP Office system or user language setting.
- An additional language file can be uploaded to a phone.

Related links

[Phones](#) on page 28

3735

The 3735 is available in two versions, one with support for integrated alarm button functions and one without alarm button support.

Avaya 3735	Features	
	As per the 3730 plus: <ul style="list-style-type: none"> • Alarm button • Cleanable, IP44 • Option: Bluetooth for headset • Color display (2", 240 x 320 pixels). • SMS Message length up to 160 characters. 30 received/sent messages. Requires AIWS. 	
	Dimensions	136 x 53 x 21mm
	Weight	130g
	Battery Type	920 mAh, Li-Pol 3.7V. Charge time 4 hours.
	Speech Time	> 20 hours (13 hours with Bluetooth option).
	Standby Time	> 120 hours.

- For systems installed using IP Office provisioning, the language used is set by the IP Office system or user language setting.
- An additional language file can be uploaded to a phone.

Related links

[Phones](#) on page 28

3745

Avaya 3740	Features		
	<ul style="list-style-type: none"> • High quality voice DECT phone, GAP/CAP compliant • Easy access to PBX services • Voicemail including message icon. • Manual and automatic keypad lock • Local directory: 250 entries. • Central directory from the IP Office. • Call list with the 25 last calls • Vibrator • Loudspeaker/hands free (full-duplex) • Central Management and software download • Headset socket (IP65 plug). • 19 Languages Czech, Danish, Dutch, English, Finnish, French, German, Greek, Hungarian, Italian, Norwegian, Polish, Portuguese (Brazilian), Portuguese, Russian, Slovakian, Spanish, Swedish and Turkish. • Ruggedized. • IP65 Classified. • Wide temperature range: -10C to +55C. • Colour display (128 x 160 pixels). • SMS Message length up to 160 characters. 30 received/sent messages. Requires AIWS. • GAP compatible. 		
	<table border="1"> <tr> <td data-bbox="656 1388 894 1430">Dimensions</td> <td data-bbox="894 1388 1479 1430">143 x 59 x 29mm</td> </tr> </table>	Dimensions	143 x 59 x 29mm
	Dimensions	143 x 59 x 29mm	
	<table border="1"> <tr> <td data-bbox="656 1430 894 1472">Weight</td> <td data-bbox="894 1430 1479 1472">180g</td> </tr> </table>	Weight	180g
	Weight	180g	
	<table border="1"> <tr> <td data-bbox="656 1472 894 1514">Battery Type</td> <td data-bbox="894 1472 1479 1514">920 mAh, Li-Ion 3.7V. Charge time 4 hours.</td> </tr> </table>	Battery Type	920 mAh, Li-Ion 3.7V. Charge time 4 hours.
Battery Type	920 mAh, Li-Ion 3.7V. Charge time 4 hours.		
<table border="1"> <tr> <td data-bbox="656 1514 894 1556">Speech Time</td> <td data-bbox="894 1514 1479 1556">> 12 hours with Bluetooth, 10 hours without..</td> </tr> </table>	Speech Time	> 12 hours with Bluetooth, 10 hours without..	
Speech Time	> 12 hours with Bluetooth, 10 hours without..		
<table border="1"> <tr> <td data-bbox="656 1556 894 1602">Standby Time</td> <td data-bbox="894 1556 1479 1602">> 90 hours.</td> </tr> </table>	Standby Time	> 90 hours.	
Standby Time	> 90 hours.		

- For systems installed using IP Office provisioning, the language used is set by the IP Office system or user language setting.
- An additional language file can be uploaded to a phone.

Related links

[Phones](#) on page 28

3749

Avaya 3749	Features										
	<ul style="list-style-type: none"> • High quality voice DECT phone, GAP/CAP compliant • Easy access to PBX services • Voicemail including message icon. • Manual and automatic keypad lock • Local directory: 250 entries. • Central directory from the IP Office. • Call list with the 25 last calls • Vibrator • Option: Bluetooth. • Loudspeaker/hands free (half-duplex) • Central Management and software download • Headset socket (IP65 plug). • 19 Languages Czech, Danish, Dutch, English, Finnish, French, German, Greek, Hungarian, Italian, Norwegian, Polish, Portuguese (Brazilian), Portuguese, Russian, Slovakian, Spanish, Swedish and Turkish. • Ruggedized. • IP65 Classified. • Intrinsically Safe. Conforms to ATEX/IECEX • Wide temperature range: -10C to +40C. • Colour display (128 x 160 pixels). • SMS Message length up to 160 characters. 30 received/sent messages. Requires AIWS. • GAP compatible. 										
	<table border="1"> <tr> <td data-bbox="660 1501 894 1537">Dimensions</td> <td data-bbox="894 1501 1471 1537">143 x 59 x 29mm</td> </tr> <tr> <td data-bbox="660 1537 894 1579">Weight</td> <td data-bbox="894 1537 1471 1579">180g</td> </tr> <tr> <td data-bbox="660 1579 894 1621">Battery Type</td> <td data-bbox="894 1579 1471 1621">920 mAh, Li-Ion 3.7V. Charge time 4 hours.</td> </tr> <tr> <td data-bbox="660 1621 894 1663">Speech Time</td> <td data-bbox="894 1621 1471 1663">> 12 hours with Bluetooth, 10 hours without..</td> </tr> <tr> <td data-bbox="660 1663 894 1705">Standby Time</td> <td data-bbox="894 1663 1471 1705">> 90 hours.</td> </tr> </table>	Dimensions	143 x 59 x 29mm	Weight	180g	Battery Type	920 mAh, Li-Ion 3.7V. Charge time 4 hours.	Speech Time	> 12 hours with Bluetooth, 10 hours without..	Standby Time	> 90 hours.
Dimensions	143 x 59 x 29mm										
Weight	180g										
Battery Type	920 mAh, Li-Ion 3.7V. Charge time 4 hours.										
Speech Time	> 12 hours with Bluetooth, 10 hours without..										
Standby Time	> 90 hours.										

- Due to the power restrictions for intrinsically safe handset operation, the display brightness is lower, the loudspeaker and ringer volumes are lower and the audible ringer and vibrating

alert cannot be activated simultaneously. An additional language file can be uploaded to a phone.

- For systems installed using IP Office provisioning, the language used is set by the IP Office system or user language setting.
- An additional language file can be uploaded to a phone.

Related links

[Phones](#) on page 28

3755

Physical	
Dimensions (l × w × d)	150 × 64 × 23 mm
Weight	175 g (including battery and clip)
Material	Case: PC / ABS, Key pad: PC, Clip: PA
Color	<ul style="list-style-type: none"> • Handset: Gray or Black • Front plates: Black (standard), Steel Gray, Turquoise, Green, and Orange
Display	<ul style="list-style-type: none"> • 40 × 50 mm (2.4 in), TFT display • Multiple colors with high resolution, 262 K individual colors • 240 × 320 pixel LCD with white LED backlight
Clip	Hinge-type (standard) or swivel-type or no clip
User interface	
Indicator	<ul style="list-style-type: none"> • Multicolor LED on top for visual indication of incoming call or message • The LED can also be used for visual indication of normal function
Vibrator	Incoming call, incoming message, or alarm
Battery and charging	
Note: All battery times are based on optimal conditions (no roaming or handover and black display).	
Type	Li-ion 3.7 V 920 mAh
Speech time	<ul style="list-style-type: none"> • Up to 18 hour (Bluetooth disabled and Location features disabled) • Up to 12 hour (with Bluetooth headset in use and Location features disabled) • Up to 16 hour (Bluetooth disabled and Location features enabled) • Up to 10 hour (with Bluetooth headset in use and Location features enabled)
Stand-by time	<ul style="list-style-type: none"> • Up to 120 hour (Black screen saver activated and Location features disabled) • Up to 60 hour (Black screen saver activated and Location features enabled)

Table continues...

Charge time	< 4 h
Connectors	
Multi-purpose connector	With USB for fast software download, configuration and battery charging
Headset connector	Standard 3.5 mm, screw enforced 3.5 mm
Audio	
Ring signal	<ul style="list-style-type: none"> • Maximum sound level 100 dBA @ 10 cm • Adjustable in 8 steps
Earpiece	Adjustable in 8 steps of 3dB each
Loudspeaker	Duplex loudspeaking function
Voice codecs	G.722.2 and G.726
Languages	
Menu and message languages	Czech, Danish, Dutch, English, Finnish, Flemish, French, German, Greek, Hungarian, Italian, Norwegian, Polish, Portuguese (Brazilian), Portuguese (European), Russian, Slovakian, Spanish, Swedish and Turkish + one downloadable
Phonebook	
Central phonebook	Maximum 40 characters in a name and 20 digits in a number
Company phonebook	<ul style="list-style-type: none"> • Maximum 24 characters in a name and 24 digits in a number (1 number per name) • 1000 entries
Local phonebook	<ul style="list-style-type: none"> • 48 character name • 24 digit work number • 24 digit mobile phone number • 24 digit other number • Selectable ring tones per contact • 250 entries
Telephony	
Indication	14 ring signals, illuminated display, vibrator and LED
Answer call	Button press or auto answer
Call list storage capacity	50 calls (received, dialed, and missed) with time stamps
Messaging	
Maximum message length	Up to 140 characters from handset, depending on language and system settings
Storage capacity	30 received/sent messages (> 20 000 characters)
Multicast groups per handset	The handset can be a member in maximum 8 different messaging groups

Table continues...

Message character encoding	<ul style="list-style-type: none"> • SMS Standard • Latin-1 • UTF-8
Additional	
	<ul style="list-style-type: none"> • Wideband audio • High quality voice • Centralized management • Easy access to PBX services • Easy replacement of handset • Programmable headset button • Programmable handset restrictions • Site survey tool • Customizable sounds • Customizable menus • Easily replaceable battery • Sound off key • Mute button • 180 degrees rotation of message or call information • Clear message and call lists in charger
Bluetooth	
Bluetooth radio	ISM 2.4000–2.4835 GHz
Supported version	5.0
Supported profiles	Headset and Handsfree
Radio	
Automatic DECT protocol detection	Automatic detection and configuration for US DECT and EU DECT at first registration
Frequency range	<ul style="list-style-type: none"> • 1880–1900 MHz: Europe, Africa, Middle East, Australia, New Zealand and parts of Asia • 1910–1920 MHz: Brazil • 1910–1930 MHz: Latin America • 1920–1930 MHz: US
Modulation	GFSK
Channel spacing	1.728 MHz
Antenna	2 integral antennas for antenna diversity
Sensitivity	–93 dBm

Table continues...

Maximum average power	<ul style="list-style-type: none"> • EU/LA/BR: 10 mW • US: 4 mW
Environmental	
Operating temperature	-10°C to +55°C (+14°F to +131°F)
Storage temperature	-20°C to +60°C (-4°F to +140°F)
Relative operating humidity	5 % to 95 % non-condensing
Relative storage humidity	5 % to 95 % non-condensing
Storage life	At least 7 years, depending on the storage environment
Service life	At least 7 years, depending on the operating conditions
Transport management	No special requirements for transportation
Disposal management	The Avaya Wireless Handset 3735 phone does not contain expensive and toxic materials. Do not throw the device into unsorted household waste. Use designated utilization points for the disposal of e-waste

Related links

[Phones](#) on page 28

3759

Physical	
Dimensions (l × w × d)	150 × 64 × 23 mm
Weight	175 g (including battery and clip)
Material	Case: PC / ABS, Key pad: PC, Clip: PA
Color	<ul style="list-style-type: none"> • Handset: Gray or Black • Front plates: Black (standard), Steel Gray, Turquoise, Green, and Orange
Display	<ul style="list-style-type: none"> • 40 x 50 mm (2.4 in), TFT display • Multiple colors with high resolution, 262 K individual colors • 240 × 320 pixel LCD with white LED backlight
Clip	Hinge-type (standard) or swivel-type or no clip
User interface	
Indicator	<ul style="list-style-type: none"> • Multicolor LED on top for visual indication of incoming call or message • The LED can also be used for visual indication of normal function
Vibrator	Incoming call, incoming message, or alarm

Table continues...

Battery and charging	
Note: All battery times are based on optimal conditions (no roaming or handover and black display).	
Type	Li-ion 3.7 V 920 mAh
Speech time	<ul style="list-style-type: none"> • Up to 16 hours (Bluetooth disabled and location features enabled) • Up to 18 hours (Bluetooth disabled and location features disabled) • Up to 10 hours (with Bluetooth headset in use and location features enabled) • Up to 12 hours (with Bluetooth headset in use and location features disabled)
Stand-by time	<ul style="list-style-type: none"> • Up to 120 hours (Black screen saver activated or Location features disabled) • Up to 60 hours (Black screen saver activated or Location features enabled)
Charge time	Approximately 3 hours in CR3 charging rack and DC3 desktop charger
Connectors	
Multi-purpose connector	With USB for fast software download, configuration and battery charging
Headset connector	Standard 3.5 mm, screw enforced 3.5 mm
Audio	
Ring signal	<ul style="list-style-type: none"> • Maximum sound level 90 dBA @ 10 cm • Adjustable in 8 steps
Earpiece	Adjustable in 8 steps of 3dB each
Loudspeaker	Duplex loudspeaking function
Voice codecs	G.722.2 and G.726
Languages	
Menu and message languages	Czech, Danish, Dutch, English, Finnish, Flemish, French, German, Greek, Hungarian, Italian, Norwegian, Polish, Portuguese (Brazilian), Portuguese (European), Russian, Slovakian, Spanish, Swedish and Turkish + one downloadable
Phonebook	
Central phonebook	Maximum 40 characters in a name and 20 digits in a number
Company phonebook	<ul style="list-style-type: none"> • Maximum 24 characters in a name and 24 digits in a number (1 number per name) • 1000 entries
Local phonebook	<ul style="list-style-type: none"> • 48 character name • 24 digit work number • 24 digit mobile phone number • 24 digit other number • Selectable ring tones per contact • 250 entries
Telephony	

Table continues...

Indication	14 ring signals, illuminated display, vibrator and LED
Answer call	Button press or auto answer
Call list storage capacity	50 calls (received, dialed, and missed) with time stamps
Messaging	
Maximum message length	Up to 140 characters from handset, depending on language and system settings
Storage capacity	30 received/sent messages (> 20 000 characters)
Multicast Groups per handset	The handset can be a member in maximum 8 different Messaging groups
Message character encoding	<ul style="list-style-type: none"> • SMS Standard • Latin-1 • UTF-8
Additional	
	<ul style="list-style-type: none"> • Wideband audio • High quality voice • Centralized management • Easy access to PBX services • Easy replacement of handset • Programmable headset button • Programmable handset restrictions • Site survey tool • 180 degrees rotation of message or call information • Customizable sounds • Customizable menus • Easily replaceable battery • Sound off key or Mute button • 180 degrees rotation of message or call information • Clear message and call lists in charger
Bluetooth	
Bluetooth radio	ISM 2.4000–2.4835 GHz
Supported Version	5.0
Supported Profiles	Headset and Handsfree
BLE Beacon Protocol	iBeacon
Radio	

Table continues...

Automatic DECT protocol detection	Automatic detection and configuration for US DECT and EU DECT at first registration
Frequency range	<ul style="list-style-type: none"> • 1880–1900 MHz: Europe, Africa, Middle East, Australia, New Zealand and parts of Asia • 1910–1920 MHz: Brazil • 1910–1930 MHz: Latin America • 1920–1930 MHz: US
Modulation	GFSK
Channel spacing	1.728 MHz
Antenna	2 integral antennas for antenna diversity
Sensitivity	–93 dBm
Maximum average power	<ul style="list-style-type: none"> • EU/LA/BR: 10 mW • US: 4 mW
Environmental	
Operating temperature	–10°C to +55°C (+14°F to +131°F)
Storage temperature	–20°C to +60°C (–4°F to +140°F)
Relative operating humidity	5 % to 95 % non-condensing
Relative storage humidity	5 % to 95 % non-condensing
Storage life	At least 7 years, depending on the storage environment
Service life	At least 7 years, depending on the operating conditions
Transport management	No special requirements for transportation
Disposal management	The Avaya Wireless Handset 3759 phone does not contain expensive and toxic materials. Do not throw the device into unsorted household waste. Use designated utilization points for the disposal of e-waste

Related links

[Phones](#) on page 28

Chargers

A number of different types of charger exist for 3700 Series phones. Note that chargers are not necessarily interchangeable between different phone models.

- **Basic Chargers**

These are simple single-phone charger for charging only.

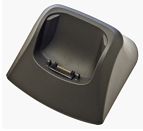

- **Advanced Chargers**

These are single-phone chargers with USB and LAN sockets. These allow the phone docked with the charger to be accessed using the Device Manager application (browser access via the AIWS unit and charger LAN port or WinPDM PC application access via the USB port).

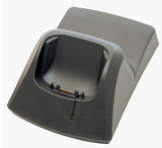

- **Rack Chargers**

These are 6 phone advanced chargers.



- **Battery Chargers**

These chargers allows the charging of up to 6 batteries separate from the phones.

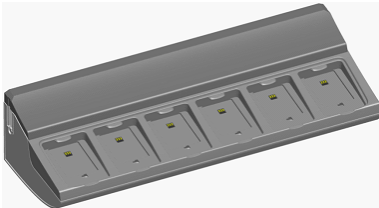

Related links

[Phones](#) on page 28

Chapter 5: Avaya In-Building Wireless Server

The AIWS (*Avaya In-Building Wireless Server*) unit supports several functions:

- It allows SMS messaging between handsets.
- It also allows wireless software upgrades and configuration of the handsets. Without an AIWS, handsets can only be upgraded and configured when in an advanced charger or a rack charger.
- For IP Office R5, the AIWS provides directory integration between the IP Office and the Avaya Wireless DECT system.
 - This requires the IP Office security settings to allow **TFTP Directory Read (Unsecured Interfaces)**.
 - On Linux-based IP Office servers, the **Solution > ☰ > Platform View > Settings > System > Firewall Settings** must allow access using port 69.
- For IP Office R6 and higher, the master base station does directory integration when an AIWS is not present. However, if SMS is required, the AIWS is used for both functions.

The unit is managed using a web browser and requires a fixed IP address.

For IP Office 8.0, the AIWS2 is supported. The AIWS2 is the application server that has replaced the AIWS1 design.

Related links

[AIWS1](#) on page 43

[AIWS1 Status Lamp](#) on page 45

[AIWS2](#) on page 46

AIWS1

In this release of IP Office, this design of AIWS has now been replaced by the AIWS2.

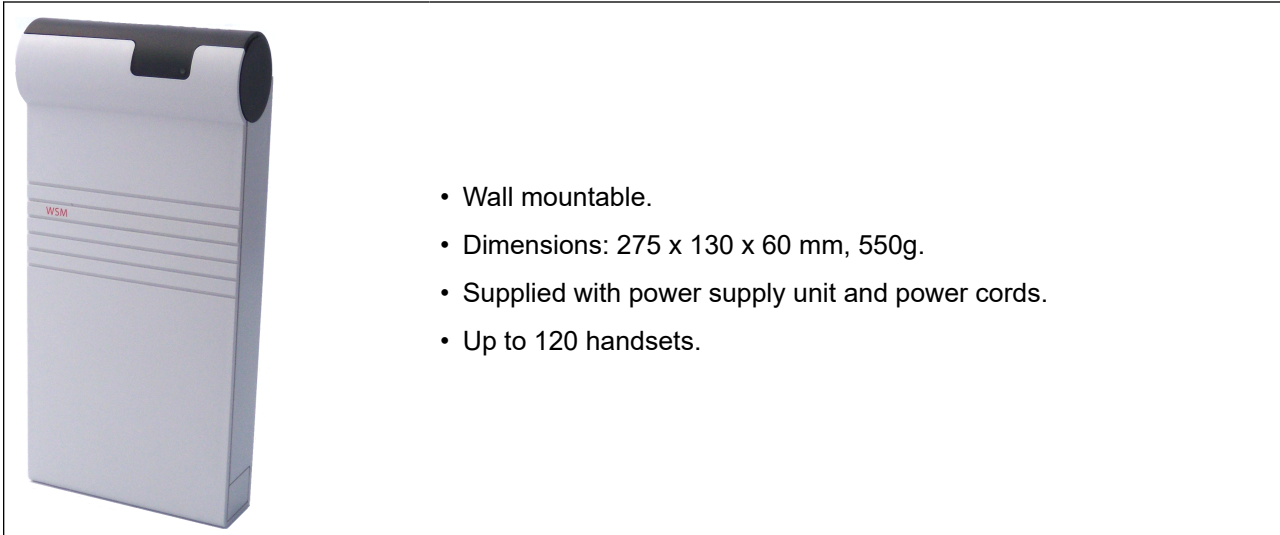

Several variants of the server are available. There is no upgrade available between variants.

Feature\IWS2 Variant	Basic	Standard	Enterprise	OAP
Feature\IWS2 Variant	Basic	Standard	Enterprise	OAP
Central Phonebook	Yes	—	Yes	Yes
Corporate Directory Access	Yes (TFTP only)	Yes (TFTP and LDAP)	—	—
SMS Support	Yes	Yes	Yes	Yes
Basic Web Messaging	Yes	Yes	Yes	Yes
Netpage Web Messaging	—	Yes	—	—
Over-the-Air Handset Software Upload	—	Yes	Yes	—
Over-the-Air Handset Configuration Upload	Yes	Yes	Yes	—
Handset Software Upload via Advanced/Rack Charger	—	Yes	Yes	—

Table continues...

Feature\AIWS2 Variant	Basic	Standard	Enterprise	OAP
handset Configuration Upload via Advanced/Rack Charger	—	Yes	Yes	—
Virtual SIM Card	—	Yes	Yes	—
AIWS as Protocol Converter	—	—	—	Yes

Related links

[Avaya In-Building Wireless Server](#) on page 43

AIWS1 Status Lamp

Colour	State	Description
Green	On	Running
	On	Failsafe or Network setup mode
Orange	Flashing (1 second on/off)	Image installation mode
	Fast flash (100ms on/off)	Starting
	Intermittent flash (100ms on/1 second off)	Restart
	Slow flash (2 seconds on/3 seconds off)	Halted (auto restart after 10 minutes)
	Wink (5 seconds on/100ms off)	Unlicensed
	Wink (5 seconds on/100ms off)	Unlicensed
Red	On	Low voltage
	Intermittent flash (100ms on/1 second off)	License error
	Flashing (1 second on/off)	Watch dog reset
	Slow flash (2 seconds on/3 seconds off)	Shutdown
	Very slow flash (3 seconds on/3 seconds off)	Memory error
	Wink (5 seconds on/100ms off)	Network error/Module key error

Related links

[Avaya In-Building Wireless Server](#) on page 43

AIWS2

IP Office 8.0, supports the AIWS2. The AIWS2 is an application server for the system. It can run applications such as SMS messaging, centralized phonebook, and corporate directory access. The AIWS2 supports centralized device management, including firmware and configuration upgrades over the air.

The AIWS2 has replaced the AIWS1



- Wall mounting brackets are included with the unit. Various other mounting kits are available.
- Built-in power supply: The AIWS is supplied with a number of power leads suitable for most locales.
- For installation and maintenance, this server is managed by a PC using Windows Internet Explorer (7.0 or above) and Sun's Java Runtime Environment.

Several variants of the server are available. There is no upgrade available between variants.

Feature\AIWS2 Variant	Basic	Basic+	Standard	OAP
NTP Server	Yes	Yes	Yes	Yes
Central Phonebook	Yes	Yes	Yes	Yes
Corporate Directory Access (TFTP from IP Office)	Yes	Yes	Yes	—
SMS Support	Yes	Yes	Yes	Yes

Table continues...

Feature\AIWS2 Variant	Basic	Basic+	Standard	OAP
Basic Web Messaging	Yes	Yes	Yes	Yes
Netpage Web Messaging	—	Yes[1]	Yes	—
Over-the-Air Handset Software Upload	—	Yes[1]	Yes[2]	—
Over-the-Air Handset Configuration Upload	—	Yes[1]	Yes[2]	—
Handset Software Upload via Advanced/Rack Charger	—	Yes[1]	Yes[2]	—
Handset Configuration Upload via Advanced/Rack Charger	—	Yes[1]	Yes[2]	—
Virtual SIM Card	—	Yes[1]	Yes[2]	—
AIWS as Protocol Converter	—	—	—	Yes

1. Up to 32 handsets.
2. Up to 120 handsets.

Related links

[Avaya In-Building Wireless Server](#) on page 43

[Front Panel](#) on page 48

[Rear Panel](#) on page 49

[Status LED](#) on page 49

[Power LED](#) on page 49

[Mode LED](#) on page 50

Front Panel



1. Power LED

Indicates the status of the power supply to the unit. See [Status LED](#) on page 49.

2. Status LED

Indicates the status of the unit.

3. Mode Switch and LED

Pressing this switch twice will put the unit into mass storage mode. The unit will automatically return to normal operation after 10 minutes. While in mass storage mode, the LED in the switch flashes. Mass storage mode is used to allow a Windows PC to download the suitable drivers for USB cable connection to the Management port.

4. Restart Switch

5. SD Card Slot

Not used for IP Office operation.

6. USB Ports

Not used for IP Office operation.

7. Management Port

This port can be used for a USB connection to a PC in order to do unit configuration. Installation of the drivers for this requires the unit to be put into mass storage mode using the Mode Switch (see above). The address used for this port is 192.5.36.229.

Related links

[AIWS2](#) on page 46

Rear Panel



1. LAN 1

This is the LAN port which should be used for connection to the same LAN as the DECT system and IP Office.

2. LAN 2

Not used.

3. Power Connectors

The unit supports a number of different methods for power connection. If using the C10 port, a number of power cables are supplied with the unit.

Related links

[AIWS2](#) on page 46

Status LED

Colour	State	Description
Blue	On	OK. AIWS operational.
	Fast Flash	Starting up or shutting down.
Red	Fast flash	Error or fault.
	Slow flash	Warning
Yellow	Double blink	Waiting for automatic startup.

Related links

[AIWS2](#) on page 46

Power LED

Colour	State	Description
Blue	On	Power OK.
Red	Fast flash	Shutting down due to low voltage.
	Slow flash	Low voltage.

Related links

[AIWS2](#) on page 46

Mode LED

This LED is incorporated into the Mode button on the front of the unit.

Colour	State	Description
Blue	Slow flash	Mass storage mode.

Related links

[AIWS2](#) on page 46

Part 2: Performing a Site Survey

Chapter 6: Site Survey and Planning

Avaya cannot give precise recommendations for a site survey as every site will vary. However, a site survey is a prerequisite to installation in all cases. The correct and effective placement of base stations will prevent problems and maximize coverage. Most issues with any DECT system will arise from the number and positioning of the base stations.

The basic aim is to ensure:

- Base station coverage in all areas of expected DECT phone usage.
- Sufficient number of base stations covering each area for the number of expected simultaneous users (up to 8 per base station) in that area.
- Sufficient overlap between areas of base station coverage to allow for call handover when DECT phone users are moving.
- Where possible, synchronization of each base station with more than one other base station.

Related links

[Factors to Consider](#) on page 52

[Base Station Signal Strength](#) on page 54

[Handover](#) on page 55

[Base Station Synchronization](#) on page 56

[Advanced Scenario: Separated Locations](#) on page 56

[Performing a Survey](#) on page 57

Factors to Consider

In ideal open field conditions, the range between a phone and a standard base station can be up to 600 metres (2000 feet). However, in real conditions with obstacles absorbing signal strength and reflected signals giving increased error rates, the range is more realistically between 30 metres (100 feet) indoors and 300 metres (1000 feet) outdoors.

In practice, no rules or guarantees can be specified for base station coverage. Coverage is affected by too many factors that are unique to each site. The following is a guide to some of the factors that can affect coverage and which you should consider and look for during any site survey.

Type	Potential Factors
Obvious causes of signal problems	<ul style="list-style-type: none"> • Metal surfaces. • Concrete thickness greater than 1 metre (3 feet).
Beware of	<ul style="list-style-type: none"> • Windows with Reflective Film or Specialized Glass. These produce increased signal reflection and reduced signal pass-through. • Wire Meshes and Grills with Apertures of Less than 4cm (1.5 inches). These block signals as effectively as continuous metal sheet. • Fire Doors These block the signals. In multi-occupancy building such as hotels, the high number of fire-doors may be a problem. • Stair Wells In modern office buildings, stair wells frequently combine concrete building supports, fire doors and the intervening floor material, making them a special problem. • Screened Rooms Typically found in offices involved with TV, video and radio production, but also possible in computer centers. • Empty Sites Do not perform a survey on a site that is not yet occupied. The survey results will differ from those of the same site once occupied by the customer business. Similarly the survey should be performed during normal business hours in order to assess the areas of usage and the effect of equipment being operated and moved.
Be aware of	<ul style="list-style-type: none"> • Signal Direction The signal from a base station does not propagate evenly in all directions. The signal typically propagates strongest in the horizontal plane. However the ability for a base station to serve callers located on floors above or below it should not be ignored. This may allow coverage to be extended to areas not frequently used and so not meriting a dedicated local base station. • Other Radio Signals The ability to receive normal broadcast radio signals in an area is not an indication that DECT signaling will be received and vice versa. • Rack Chargers A rack charger (6 phones) immediately creates an area where a single base station (8 calls) would be near maximum capacity. Look to provide overlapping base station support to areas where rack chargers will be located.

Related links

[Site Survey and Planning](#) on page 52

Base Station Signal Strength

The diagram below indicates the basic measures for coverage between a base station and a DECT phone.

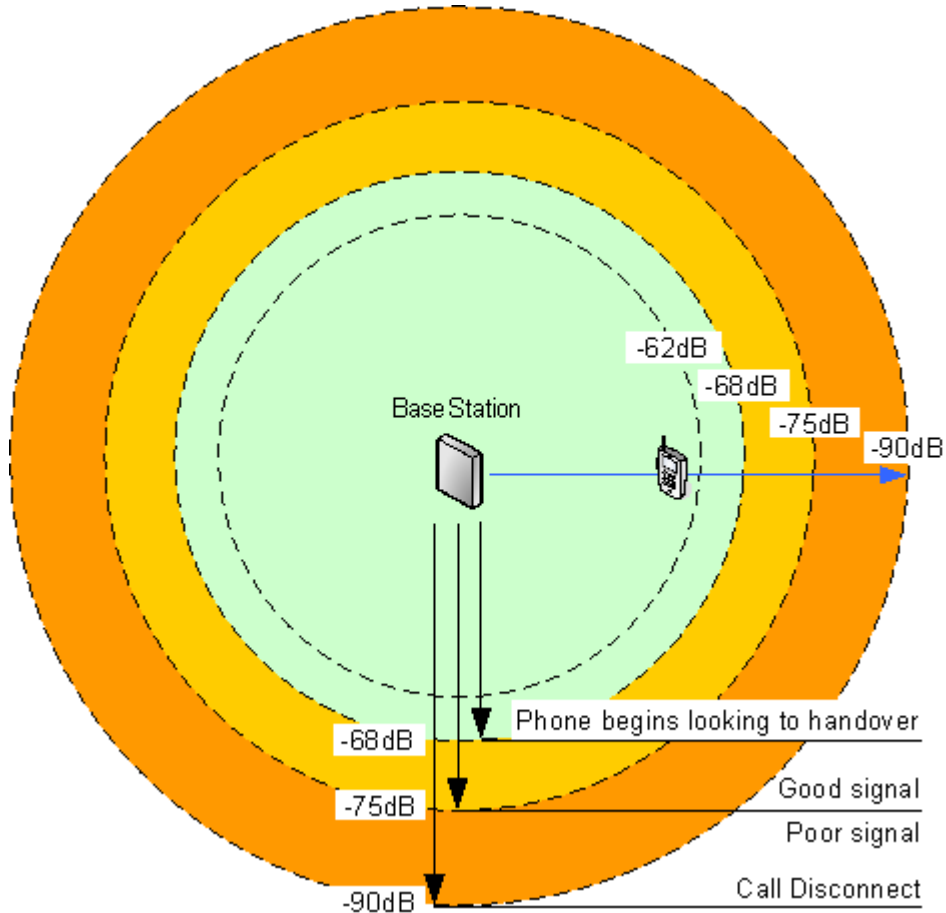

Signal	Description
-40dB	Strong signal typically seen when a phone is close to the base station.
-62dB	Minimum signal strength at which a base station will accept a phone wanting to handover from another base station.
-68dB	Signal strength below which the phone will begin looking for a base station to which it can handover.
-75dB	At this signal strength, the increased error rate will become apparent in the speech.
-90dB	At this signal strength calls are likely to disconnect. This is also the limit for one base station to synchronize with another.

Though this section focuses mainly on the measure of signal strength, the DECT signalling employs a number of methods to overcome a poor signal. The other key factor that affects signalling is the error rate. While decreasing signal strength and increasing error rate are usually related, there may be some scenarios where a higher than expected error rate occurs.

Related links

[Site Survey and Planning](#) on page 52

Handover

Once a phone is connected on a call through a particular base station, it will normally maintain connection with that base station even if the phone moves into an area with a stronger signal from another base station. However, when the signal to the phone drops below -68dB , the phone will begin looking for another base station with a better signal to which it can handover (this is often referred to as "roaming"). If the other base station signal is -62dB or higher, the phone will handover to that base station if it has free capacity.

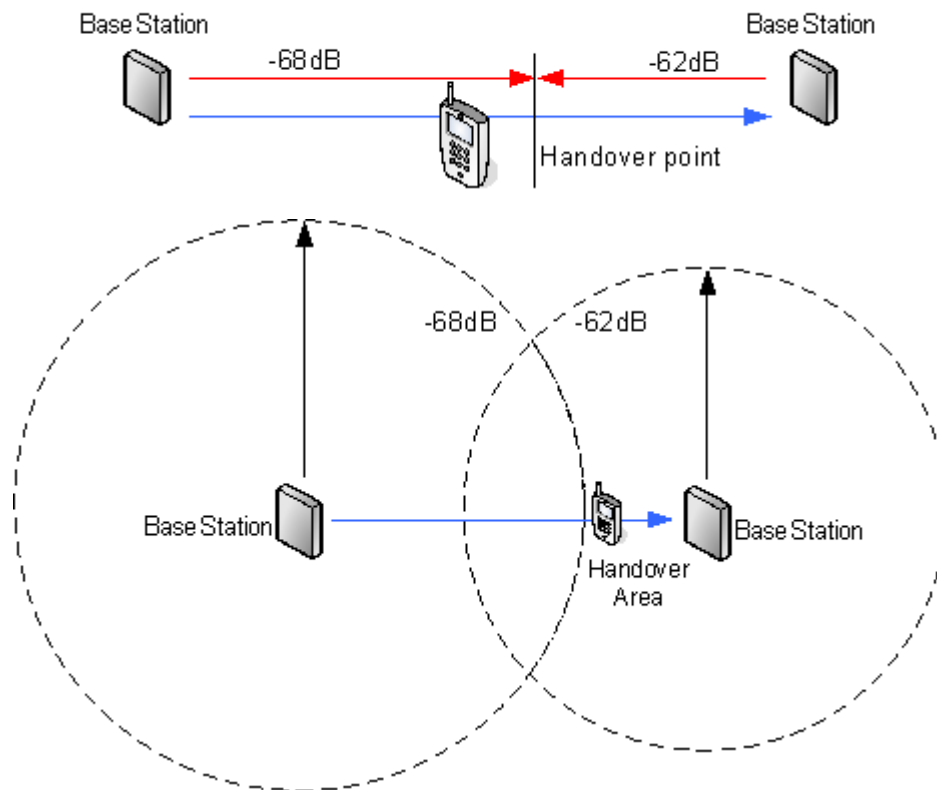
**Related links**

[Site Survey and Planning](#) on page 52

Base Station Synchronization

Base stations in the Avaya Wireless DECT system need to be synchronized with each other. This can be done with a signal as low as -90dB between base stations.

One base station is assigned as the 'air sync master', typically the master base station. Each other base station can sync directly with it or indirectly via a synchronization chain. However, it is preferable that the number of synchronization 'hops' between any particular base station and its air sync master base station is kept as low as possible. To help achieve this it is recommended that the air sync master is placed centrally within the set of base stations.

Where possible, each base station should be placed within synchronization range of more than one base station, which allows the base stations to maintain synchronization should one base station fail or be switched off for maintenance. The process of synchronizing by the shortest route to the air sync master when in synchronization range of multiple base stations is automatic.

For more information, see [Configuring Air Sync](#) on page 93.

Related links

[Site Survey and Planning](#) on page 52

Advanced Scenario: Separated Locations

In most scenarios, the master base station (Standard or Compact) is also used as the air sync master for all the other slave base stations and that is the scenario documented in this manual. However, in scenarios where you have base stations in separate locations that are not within synchronization range of each other, it is permissible to assign separate air sync masters in each location. However, there must be absolutely no overlap (<-90dB) between the separate groups of base stations. Any overlap will cause frequent loss of synchronization.

Having separate locations, each with its own synchronization, is done through the settings on the **DECT | Air Sync** tab of each base station. For each location, set the same **Sync Region** number for all the base stations at that location, using a different number for each location. In addition, use the **Sync Mode** drop-down menu to configure one of the base stations in each location as the **Master** base station.

* Note:

In deployments in mixed systems with IP Base Stations and IP-DECT Gateways, the IP-DECT Gateways need to be physically interconnected for the purpose of radio synchronization. When configuring an IP-DECT Gateway as an air sync master, use sync region 0. All other base stations should be configured as sync slaves. Systems with IPBS in sync regions that have only IPBS should use non-zero sync region number(s) and be configured with at least one sync master with the remaining IPBSs configured as sync slaves.

Related links

[Site Survey and Planning](#) on page 52

[Master Base Station Setup](#) on page 75

[Configuring Air Sync in Separated Locations](#) on page 94

[Configuring Air Sync](#) on page 238

[Configuring Air Sync in Separated Locations](#) on page 94

Performing a Survey

- While performing a survey you will require the following information:

- **Building Layout**

Accurate building plans are an essential aid to both the site survey and also for later fault analysis. Ensure that you have an accurate plan of the customer premises, including the locations of mains power outlets and network connection points.

- **The area of coverage required**

Which areas within the plans the customer expects to be covered. Do they expect coverage outside the building and or in buildings separate from the main building.

- **The number of simultaneous users within different areas**

Each base station can support up to 8 simultaneous calls (4 for a Compact Base Station).

- Perform the survey during normal business hours. The movement of large items of machinery, such as lifts and shutter doors, will then be observable during the survey.
- Ensure that you have read this documentation and understand the requirements of both phone handover and base station synchronization.
- As the survey occurs, note whether additional network connection points are required and check for main power outlets. Consider the use of Power over Ethernet, if possible, in order to simplify base station installation.

Related links

[Site Survey and Planning](#) on page 52

[Site Survey Mode](#) on page 57

Site Survey Mode

About this task

The following method is used to put a subscribed phone into site survey mode.

Procedure

1. Go to the **Call Time** menu (**Menu | Calls | Call Time**).
2. Activate the **Admin** menu by pressing ► * ◀ ◀ * ◀.
3. In **Admin** menu, select **DECT Info**.

4. Select **Link**. The phone will display information about the base station.

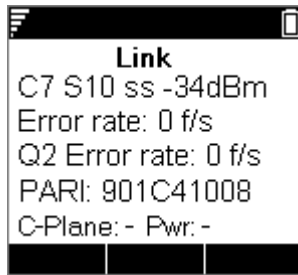

- **C7 S10**

This is the DECT signal carrier and slot.

- **ss**

This is the signal strength. This is the main value that should be recorded and accessed as you perform the survey.

Signal	Description
-40dB	Strong signal typically seen when a phone is close to the base station.
-62dB	Minimum signal strength at which a base station will accept a phone wanting to handover from another base station.
-68dB	Signal strength below which the phone will begin looking for a base station to which it can handover.
-75dB	At this signal strength, the increased error rate will become apparent in the speech.
-90dB	At this signal strength calls are likely to disconnect. This is also the limit for one base station to synchronize with another.

- **Error rate / Q2 Error rate**

These are the error (corrupted) frames per second on the signals from and to the base station.

- **PARI**

The PARI of the DECT system.

- **Bear:**

The current power output of the phone.

- **Pwr** = on hook
- **LU** = off hook, Low power
- **US** = off hook, Normal power
- **EU** = off hook, High power

Related links

[Performing a Survey](#) on page 57

Part 3: Doing a Provisioned Installation

Chapter 7: Provisioned Installation

A provisioned installation is the recommended method for both installation simplicity and handset feature support. Use Provisioned Installation for all deployments of systems comprised of only Avaya 3700 Series phones.

- **When to Use IP Office Provisioning**

IP Office provisioning simplifies installation and maintenance and provides 3700 Series phones with additional IP Office specific features (see [IP Office User Features](#) on page 147). Avaya recommends this installation method for new installations whenever possible.

- Provisioned installation in pre-configured or auto-create modes should be used for all installations with just 3700 Series phones.
- Provisioned installation in pre-configured mode should be used for all installations with a mix of 3700 Series phones and other DECT phones.
- Provisioned installation should not be used for installations without 3700 Series phones. For information on installations without 3700 Series phones see [Non-Provisioned Installation](#) on page 211.

For more information on provisioned installations, refer to the following sections:

1. [Unpacking the DECT Software](#) on page 63.
2. [Configuring IP Office](#) on page 65.
3. [Configuring the Master Base Station](#) on page 75.
4. [Configuring IP Slave Base Stations](#) on page 96.
5. [Mounting Base Stations](#) on page 105.
6. [Subscribing Phones](#) on page 108.

 **Note:**

The installation process and screen captures used in this document are for example only. Other methods and order of installed devices can be used once you become familiar with the installation process. For example, installing all of the slave base stations before installing the master base station.

Related links

- [IP Office Installation Requirements](#) on page 61
- [IP Base Station Installation Requirements](#) on page 61
- [Phone Subscription Requirements](#) on page 62
- [Unpacking the DECT Software](#) on page 63

[Device Management](#) on page 64

IP Office Installation Requirements

- It is assumed that you are familiar with installation and configuration of IP Office systems.

Information

- Service user name and password for IP Office configuration access.
- Service user name and password for IP Office security settings access.
- IP Office IP address.
- Avaya IP Endpoint licenses.

Parts

- IP Office software DVD or image of the IP Office admin software.

Tools

- Programming PC with IP Office Manager application installed. You must have administrator rights on this PC to change its IP address settings unless it is functioning as a DHCP client.
- Software for zip file extraction.

Related links

[Provisioned Installation](#) on page 60

[Non-Provisioned Installation](#) on page 211

IP Base Station Installation Requirements

Information

- Avaya Wireless DECT SARI.
- Base Station IP Addresses.
- Detailed plans from the site survey indicating the intended base station locations, LAN sockets and if necessary power supply outlets.

Parts Required

- Base station

Includes:

- Base station.
- Two 3.5mm screws and two 6mm wall plugs suitable for wall mounting onto a solid wall (brick or similar).
- 1.2 metre (4 foot) LAN cable. If this is replaced with a longer cable the replacement should be a CAT5 Ethernet LAN cable.

! **Important:**

For IP Office Release 10.0 and higher, IPBS1 base stations are only supported as slave radio base stations. IPBS1 base stations are no longer supported in other roles, for example as master base stations. For systems being upgraded, any existing IPBS1 base station being used in a non-slave role must first be replaced in that role with an IPBS2/ IPBS3 or IPBL1.

- If using Power over Ethernet:
 - The base station supports Power over Ethernet, IEEE 802.3af, class 2.
- If not using Power over Ethernet:
 - Base station power supply unit.

Required if not using Power over Ethernet to power the base station. Note that the base station power supply units include an 8 metre (26 feet) cable from the PSU to the base station. Check that you have the correct type of power supply unit for the locale.

- BSX-0013: Europe (except United Kingdom).
- BSX-0014: United Kingdom.
- BSX-0015: USA/Canada.
- BSX-0016: Australia.
- Mains power outlet socket.
- LAN Socket.

Related links

[Provisioned Installation](#) on page 60

Phone Subscription Requirements

Information

- Service user name and password for IP Office configuration.
- User names and extension numbers for the DECT phones.
- Phone IPEI numbers if using pre-configured installation mode.

Tools

- **IP Office Manager.**
- **Device Manager**

The software installed on each handset may need to be upgraded to match that supplied with the Avaya Wireless DECT software. This is done using the Windows Device Manager software to upgrade phones via an advanced charger or using AIWS Device Manager to upgrade phones over the air.

- Web browser (Internet Explorer or Firefox are supported).

Related links

[Provisioned Installation](#) on page 60

Unpacking the DECT Software

About this task

Before installing Avaya Wireless DECT, in addition to installing IP Office Manager, unpack the Avaya Wireless DECT software onto your programming PC.

- Avaya Wireless DECT is supported on a range of Avaya systems. For IP Office operation, you must use software specifically documented as tested and supported with IP Office. Details of supported software is included in the IP Office Technical Bulletin for each release.

Procedure

1. On the programming PC, create a folder with a name indicating its purpose, for example `c:\IP_DECT_R4`.
2. Within the IP Office Administrator Application software (that is the software from which IP Office Manager is installed), locate the folder `IPDECT`.
 - The folder contains a file `DECT_R4.zip`. This is the file containing software for Avaya Wireless DECT.
 - The file `IPDECT.zip` contains software for the older IP DECT product and is not used for Avaya Wireless DECT.
3. Copy the `DECT_R4.zip` file to the folder created on the programming PC.
4. Using WinZip or a similar tool, extract the contents of the zip file into the folder, maintaining the directory structure of the zip files.

The set of files should appear similar to the following.

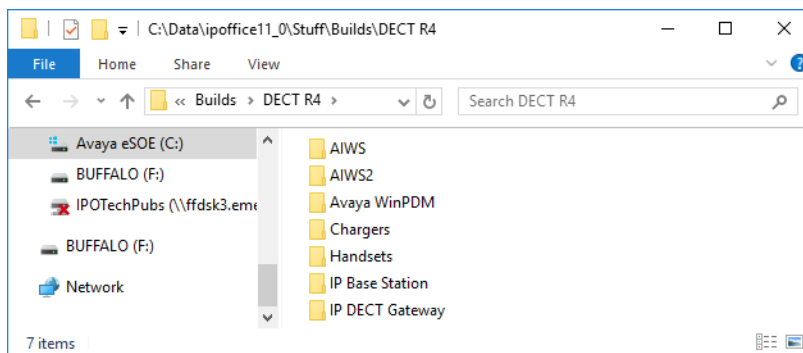

5. Check the software versions as follows:
 - Open the `IP Base Station` folder. There are separate sub-folders for each model of base station. Open each and note the software level shown as part of the `.bin`

filenames. There are separate files for the base station boot file and firmware file. All base stations in the installed system must run the same version of software.

- Open the `Handsets` folder and note the software level shown as part of the `.pkg` filenames. The handsets in the system must be running this level of software or higher.
- Open the `IP DECT Gateway` folder and note the software level shown as part of the `.bin` filenames. These versions must be of the same level as the IP Base Stations.

Related links

[Provisioned Installation](#) on page 60

Device Management

During installation (provisioned or non-provisioned) it may be necessary to upgrade the software being used by the 3700 Series phones. This is done in one of two ways:

- **Windows Device Manager**

The Windows device manager application can be used to upgrade the software of phones placed in an advanced charger and connected to the PC via USB or LAN. If using this method, install the Windows Device Manager software and load the parameter definition files supplied with the Avaya Wireless DECT software.

- **AIWS Device Management**

The AIWS device includes an integrated version of device manager that can be used to perform over the air upgrades. This method is only recommended for the maintenance of an existing system. For upgrades during the installation of a new system, Avaya recommends using Windows Device Manager.

For more information see [Upgrading Phone Software](#) on page 120

Related links

[Provisioned Installation](#) on page 60

Chapter 8: Configuring IP Office

The IP Office needs to be configured to allow communication between the IP Office and the Avaya Wireless DECT system.

Related links

- [Configuring Security Settings](#) on page 65
- [IP Office System VoIP Codecs](#) on page 68
- [Creating IP DECT Lines](#) on page 68
- [Enabling Subscription](#) on page 70
- [Adding Licenses](#) on page 72
- [Configuring a Source Number](#) on page 73

Configuring Security Settings

About this task

The provisioning connection between the IP Office control unit and the master base station uses the HTTP/HTTPS service configured in the IP Office system security settings.

- Important It is important to note that for new systems and system where the security settings have been defaulted:
- The **IPDECTService** service user used for provisioning is disabled by default.
- The TFTP Directory Read function used by handsets to display the IP Office system directory is off by default.

Procedure

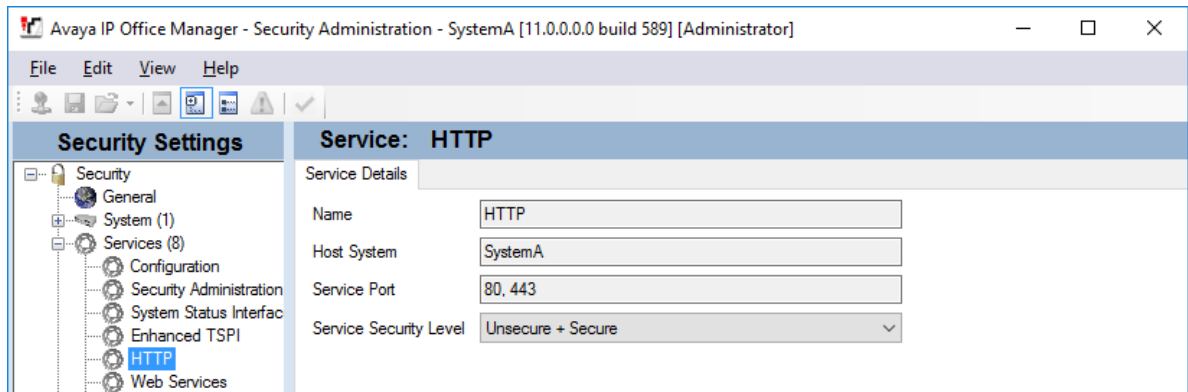

1. In the IP Office Manager **View** menu, select **Advanced** .
2. Select **File | Advanced | Security Settings**.
3. From the discovery menu select the IP Office and click **OK**.
4. Enter the systems user name and password for the security service user login. They will be different from the name and password used for IP Office configuration access.

5. Select  **Services**.



6. Select the **HTTP** service. The HTTP service affects all HTTP connections provided by the IP Office system. Changing its setting will affect applications other than just the Avaya Wireless DECT. The only option that can be changed is the **Service Security Level**. The default is **Secure + Unsecure**, meaning both http and https can be used between the base station and IP Office.

Value	Description
Unsecure Only	HTTP port 80 available and used for phone files, embedded file manager, system file upgrade, one-X Portal directory services, Avaya Wireless DECT provisioning.
Secure + Unsecure	This mode (the default) allows both unsecure HTTP (see above) and secure HTTPS (see below) connections.
Secure, Low	HTTPS port 443 available and used for Avaya Wireless DECT provisioning, IP Office Video Softphone provisioning. This option allows secure access to that service using TLS, and demands weak (for example DES_40 + MD5) encryption and authentication or higher. The service's unsecured TCP port is disabled.
Secure, Medium	This option allows secure access to that service using TLS, and demands moderate (for example DES_56 + SHA-1) encryption and authentication or higher. The service's unsecured TCP port is disabled.
Secure, High	This option allows secure access to that service using TLS and demands strong (for example 3DES + SHA-1) encryption and authentication, or higher. In addition, a certificate is required from the client (usually IP Office Manager).

7. Select  **Rights Groups**. The list of groups should contain one called **IPDECT Group**. Select that group. If the group is not present in the list, click on the  new entry icon to create the group.

8. Select the **HTTP** tab. Check that the option **DECT R4 Provisioning** and **Directory Read** are selected. Check that no other options are selected on any other tab.

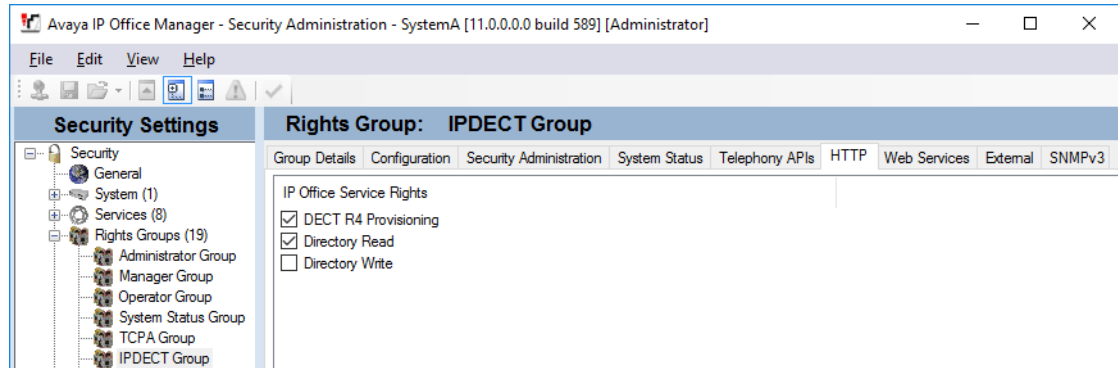

9. Select **Service Users**.
 - a. Select the Service User **IPDECTService**.

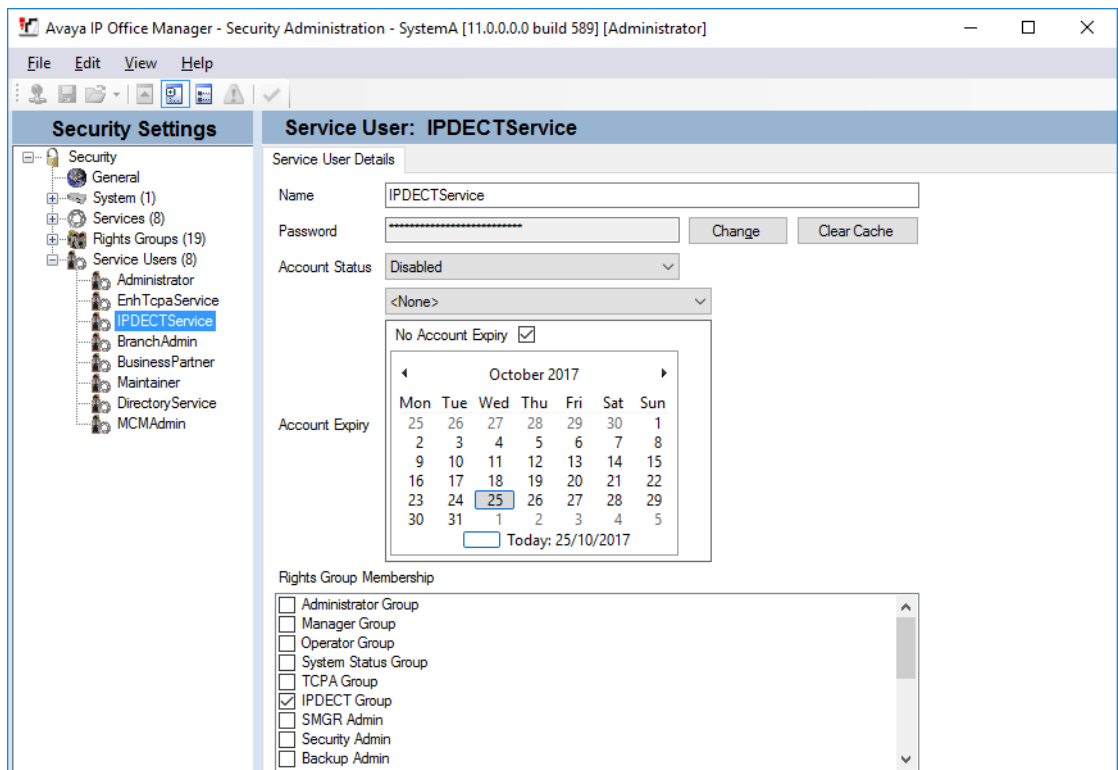

- b. In the **Rights Group Membership** list check that the user is set as a member of the IPDECT Group.
- c. Leave the **Account Status** as **Enabled** and the **Account Expiry** as **<None>**.
- d. Click on the  icon to save any changes you have made to the security settings.

 **Note:**

Avaya recommends changing the default password.

IP Office System VoIP Codecs

The VoIP codecs used can be set on the individual IP DECT line. However, where possible it is recommended to set the codecs at the system level and then use the same set of codecs across the whole system.

Even if intending to set the codecs used on the IP DECT line, the system codecs defines the codecs available for use.

- The 3700 Series phones do not support the OPUS and G.723 codecs.
- The 3755 and 3759 phones require the G.722 codec to be supported.

Procedure

1. Using IP Office Manager, retrieve the configuration from the IP Office system.
2. Click **System** and select the **VoIP** tab.
3. Use the **Available Codecs** list to select which codecs are available for use.
4. Adjust the **Default Code Selection** to ensure that the required codecs are available.
5. Click **OK** and save the configuration back to the system.

Related links



[Configuring IP Office](#) on page 65

Creating IP DECT Lines

About this task

Use the following procedure to create an IP DECT line for traffic between the IP Office and the Avaya Wireless DECT system. The line is configured with the IP address that will be assigned to the master base station. The IP Office configuration only requires a single IP DECT line.

Procedure

1. Using IP Office Manager, retrieve the configuration from the IP Office system.
2. Click on  **Line**. The list of existing lines is shown.
3. Click on the  icon and select **IP DECT Line**. The settings for an IP DECT line are displayed. If the option is grayed out then the configuration already contains an IP DECT line.

4. On the **Line** tab there are no adjustable settings. Once the system is installed and operational, this tab lists the DECT extensions.

The screenshot shows the 'Line' configuration tab. At the top, there are three tabs: 'Line', 'Gateway', and 'VoIP', with 'Line' being the active tab. Below the tabs, there is a 'Line Number' field with a dropdown arrow, currently showing '240'. To the right of this is a list box titled 'Associated Extensions' containing the numbers '301' and '302'. Below the list box is a horizontal scrollbar. At the bottom, there is a 'Description' label followed by an empty text input field.

5. Select the **VoIP** tab. This table is used to set details of the master base station.

The screenshot shows the 'VoIP' configuration tab. At the top, there are three tabs: 'Line', 'Gateway', and 'VoIP', with 'VoIP' being the active tab. Below the tabs, there are several configuration fields: 'Gateway IP Address' (192 . 168 . 0 . 226), 'Standby IP Address' (0 . 0 . 0 . 0), and 'Codec Selection' (Custom). To the right of these fields are two checkboxes: 'VoIP Silence Suppression' (unchecked) and 'Allow Direct Media Path' (checked). Below the 'Codec Selection' dropdown is a list management interface with two columns: 'Unused' and 'Selected'. The 'Unused' column contains 'G.723.1 6K3 MP-MLQ'. The 'Selected' column contains 'G.711 ULAW 64K', 'G.711 ALAW 64K', and 'G.729(a) 8K CS-ACELP'. Between the columns are five buttons: '>>>', '↑', '<<<', '↓', and '>>>'. At the bottom, there are two dropdown menus: 'TDM->IP Gain' (Default) and 'IP->TDM Gain' (Default).

6. Set the **Gateway IP Address** to match the IP address that will be assigned to the master base station.
7. Leave the **Codec Selection** set to **System Default** if it includes the required codecs, otherwise change the setting to **Custom** and adjust the selected codecs.
- The 3700 Series phones do not support the OPUS and G.723 codecs.
 - The 3755 and 3759 phones require the G.722 codec to be supported.
8. Select the **Gateway** tab
9. Enter the **SARI/PARK** and **Authentication Code** into the appropriate fields. These values are used during the phone subscription process.

*** Note:**

- To uniquely identify a single system (for example to generate a PARK code), one SARI certificate (Secondary Access Rights Identifier) is required per DECT installation to identify the system.

Related links

[Configuring IP Office](#) on page 65

Enabling Subscription

About this task

The IP DECT line settings control how the DECT handsets subscribe. For information on subscribing phone handsets, see [Phone Subscription](#) on page 258

Procedure

1. The **Line** tab will list any DECT extensions already subscribed.

The screenshot shows a configuration window with three tabs: 'Line', 'Gateway', and 'VolP'. The 'Line' tab is active. It contains a 'Line Number' field with a dropdown arrow, currently showing '240'. To the right is a list box titled 'Associated Extensions' containing the numbers '301' and '302'. Below the list box is a horizontal scrollbar. At the bottom left, there is a 'Description' label and an empty text input field.

2. Select the **Gateway** tab.

The screenshot shows the configuration interface for a Gateway. The 'Gateway' tab is active. The configuration is organized into several sections:

- General Settings:**
 - Auto-Create Extension:
 - Auto-Create User:
 - Enable DHCP Support:
- DHCP Settings:**
 - Boot File:
 - ADMM MAC Address:
 - VLAN ID:
- Base Station Address List:**
 - Empty list with 'Add...', 'Remove', and 'Edit...' buttons.
- Provisioning Settings:**
 - Enable Provisioning:
 - SARI/PARK:
 - Subscriptions:
 - Authentication Code:
- Resiliency Settings:**
 - Enable Resiliency:
 - Status Enquiry Period:
 - Prioritize Primary:
 - Supervision Timeout:

3. Change the Subscriptions mode to either **Auto-Create** or **Preconfigured**.

• **Auto-Create**

If you select this option, extension and user entries are automatically created in the IP Office configuration when the handsets are subscribed. Use this option for anonymous subscription. Ensure that no copies of the configuration are also open in Manager during subscription, as sending such a copy of the configuration back to the IP Office system will replace the subscriptions and require the handsets to be subscribed again. Following any handset subscription, a new copy of the configuration should always be loaded in IP Office Manager if any other configuration changes are required.

• **Preconfigured**

If you select this option, handset will only be able to subscribe if they match an existing IP DECT extension in the IP Office configuration.

If the IP DECT line subscription setting is set to **Preconfigured**, you must manually add extension and user entries for each handset to the IP Office configuration. To manually add extension and user entries, see [Manually Creating Extensions](#) on page 112

4. Save the configuration back to the IP Office system.

Related links

[Configuring IP Office](#) on page 65

Adding Licenses

About this task

For IP Office systems using PLDS licensing, each IP DECT extension requires an **Avaya IP Endpoint** license. This applies even if the handset subscribed to the Avaya Wireless DECT system is not an Avaya phone.

Phones without a license can still subscribe and register but are limited to making emergency calls only (calls that match a **Dial Emergency** short code). The associated user are treated as if logged off . If a license becomes available, it is assigned to any unlicensed DECT handsets first and then to any other unlicensed Avaya IP phone in the order that the phones registered.

- **Avaya IP Endpoint Licenses**

Licenses are added to the IP Office configuration and are based on a serial number unique to the system.

- Licenses are normally automatically assigned to extensions in order of registration. However, existing extensions can be configured to reserve a license. This ensures that they do not become unlicensed when newly added extensions manage to register first following a system reboot.

Related links

[Configuring IP Office](#) on page 65

[Reserving Licenses](#) on page 72

Reserving Licenses

About this task

Licenses are automatically assigned to extensions in order of registration. However existing extensions can reserve a license in order to ensure they do not become unlicensed when new extensions added to the system manage to register first following a system reboot.

Procedure

1. In IP Office Manager, select  **Extension** and then select the DECT extension.

2. Select the **IP DECT** tab. Note, the appearance of this menu will vary depending on whether you are doing a provisioned or non-provisioned installation.

The screenshot shows the configuration page for an extension. At the top, there are two tabs: 'Extn' and 'IP DECT', with 'IP DECT' being the active tab. Below the tabs, there are several configuration fields:

- DECT Line ID:** A dropdown menu showing '240 (190.168.42.224)'.
- Message Waiting Lamp Indication Type:** A dropdown menu showing 'On'.
- IPEI:** A text input field containing '0'.
- Use Handset Configuration:** An unchecked checkbox.
- Reserve Licence:** A dropdown menu showing 'Reserve Avaya IP endpoint licence'.

3. The **Reserve Avaya IP endpoint license** setting is used to reserve an existing license for the extension. The option is greyed out if the configuration does not have sufficient unreserved licenses remaining.
4. Repeat the process for any other extensions for which you want to reserve the license.
5. Save the configuration back to the IP Office system.

Related links

[Adding Licenses](#) on page 72

[IP DECT Line Setup](#) on page 216

Configuring a Source Number

About this task

The **Source Number** setting ensures that the DECT system frequency remains correctly configured following a restart of the IP Office system. The **Source Number** string is required in the IP Office configuration only when the Avaya Wireless DECT system frequency is set to either **North America** or **South America**.

Configure the **Source Number** string in IP Office Manager using the following procedure:

Procedure

1. In IP Office Manager, retrieve the IP Office configuration.
2. Navigate to the **NoUser** user.
3. Click the **Source Numbers** tab.
4. Click the **Add** button, enter the required Source Number, and click **OK**.
 - For installations in Europe, enter **IPBS_FR_EU**
 - For installations in North America, enter **IPBS_FR_NA**

Configuring IP Office

- For installations in South America, **IPBS_FR_SA**
5. Save the configuration back to the IP Office system.

Related links

[Configuring IP Office](#) on page 65

Chapter 9: Master Base Station Setup

Note:

If an IP DECT Gateway is being installed, Avaya recommends configuring the IP DECT Gateway as the master base station for the system. For information on installing an IP DECT Gateway, see [IP DECT Gateway Installation](#) on page 140.

Important:

For IP Office Release 10.0 and higher, IPBS1 base stations are only supported as slave radio base stations. IPBS1 base stations are no longer supported in other roles, for example as master base stations. For systems being upgraded, any existing IPBS1 base station being used in a non-slave role must first be replaced in that role with an IPBS2/IPBS3 or IPBL1.

Related links

- [Defaulting the Base Station](#) on page 76
- [Accessing the Base Station Configuration](#) on page 76
- [Setting the Base Station IP Address](#) on page 78
- [Configuring a Virtual Local Area Network \(VLAN\)](#) on page 79
- [Updating the Base Station Software](#) on page 81
- [Selecting Administration Mode](#) on page 83
- [Selecting Master Mode](#) on page 84
- [Setting the DECT Password](#) on page 85
- [Setting the Time Zone](#) on page 86
- [Enabling Provisioning](#) on page 87
- [Enabling HTTPS and Security Certificates in the Web Interface](#) on page 89
- [Adding Radio Connections](#) on page 90
- [Phonebook Integration](#) on page 91
- [Performing an RFP Scan](#) on page 91
- [Entering the PARI](#) on page 92
- [Configuring Air Sync](#) on page 93
- [Advanced Scenario: Separated Locations](#) on page 56

Defaulting the Base Station

About this task

This process will default a base station or IP DECT Gateway, erasing its configuration. After the unit restarts it will default to the IP address 192.168.0.1/255.255.255.0.

 **Note:**

The following instructions assume you are installing an IPBS2/IPBS3, which has one LED lamp. The IPBS1 has two LED lamps. For more information on the base station LEDs and what their statuses indicate, see [Base Station Status Lamps](#) on page 22.

Procedure

1. With only the power supply connected, switch the base station on.

The LED on the base station flashes red if no Ethernet is detected.

2. Wait approximately five seconds.

3. Press and hold the **Reset** button on the base station for approximately 10 seconds..

The LED on the base station will change to a quick flash, then the LED will go out, and then the LED returns to a slower flash.

4. Release the **Reset** button and wait for the base station to reset.

The LED should turn back on to solid amber.

5. Quickly press the **Reset** button once.

The base station reboots with default settings. The default IP is 192.168.0.1, with DHCP on, but not active. If you wish to activate DHCP reset the base station again.

 **Note:**

Avaya recommends disabling the DHCP on the base station and configuring the system with static IP addresses. For information on disabling DHCP on the base station, see [Set the Base Station IP Address](#) on page 78.

Related links

[Master Base Station Setup](#) on page 75

Accessing the Base Station Configuration

Procedure

Depending on whether DHCP is being used or not:

- a. Connect the base station to the network or PC using the LAN cable.
- b. If connected directly to the base station, change your programming PC's network address to 192.168.0.200 with subnet mask 255.255.255.0.

- c. If both your PC and the base station are connected to a LAN network with DHCP server, ensure your PC is set to act as a DHCP client or has a fixed address that is valid on the network.
- d. Start your web browser and enter the http:// or https:// followed by the IP address of the base station. The default IP address is 192.168.0.1. If a security certificate warning is displayed, select to continue to this website.
- e. The base station responds with its login menu.

- f. Select **System administration**. Enter the default user name (**admin**) and password (**changeme**) and click **Login**.
- g. A summary of the current logins is displayed. Click **OK**.
- h. The configuration menu for the base station is displayed.

Configuration	Info	Admin	EULA	Logout
General				
LAN	Version IPBS[10.0.5], Bootcode[10.0.5], Hardware[IPBS1-Y4/PD] Serial Number 09AD15300066 MAC Address (LAN) 00-01-3e-01-6f-9c DRAM 32 MB FLASH 8 MB Coder 8 Channels of G.711,G.729,G.723 SNTP Server 192.168.0.214 Time **.**.***.*** Uptime 0d 1h 38m 42s			
Administration				
Backup				
Update				
Diagnostics				
Reset				

- i. Note the software levels shown in the **General | Info** menu. These will determine if the base station software needs to be upgraded.

*** Note:**

Compact Base Stations have advanced menu options hidden by default. To enable or disable Advanced Administration menus, see [Select Administration Mode](#) on page 83 .

Related links

[Master Base Station Setup](#) on page 75

Setting the Base Station IP Address

About this task

During initial installation the IP address of a base station defaults to 192.168.0.1. The process below can be used to change the DHCP mode and IP address of a base station.

Procedure

1. From the base station configuration window, in the left-hand column, select **LAN**.
2. Select the **IP** tab.

- a. Enter the required **IP Address** and **Network Mask** for the base station. The other settings are optional.
- b. Click **OK**.

*** Note:**

The menu will prompt you with the message **Reset Required**. Do not click this or reset the base station at this stage.

- c. Select the **DHCP** tab.

- d. Using the **Mode** drop-down, select **Disabled**.
- e. Click **OK**.
- f. Select **Reset** and then select the **Reset** tab.
- g. Click **OK**.
- h. Depending on your base station, wait for the LED to return to solid blue or solid green.
- i. Log in again using the new IP address.

Related links

[Master Base Station Setup](#) on page 75

Configuring a Virtual Local Area Network (VLAN)

Both the IPBS1 and IPBS2/IPBS3 support VLAN capability. Note that the VLAN ID must be the same as the ID configured in the IPBS/IPBL, otherwise access to the IPBS/IPBL will not be possible.

On systems that do not support VLAN tagging (IEEE 802.1q), proceed to [Update the Base Station Software](#) on page 81. Note that VLAN configuration requires the **Advanced Administration** menu mode to be enabled.

* Note:

If "VLAN = 0", the Quality of Service (QoS) is inactive according to 802.1q. You should also avoid "VLAN = 1" as it is often used as a default VLAN setting.

Related links

[Master Base Station Setup](#) on page 75

[Configuring a VLAN](#) on page 79

Configuring a VLAN

About this task

Use the following procedure to configure a VLAN ID on a systems comprised of switches and endpoints that support VLAN tagging (IEEE 802.1q).

Procedure

1. Under the **Configuration** menu, navigate to **LAN** and then select the **VLAN** tab.

2. In the **ID** field, enter the parameter configured in the IPBS/IPBL.
3. Click **OK**.

Related links

[Configuring a Virtual Local Area Network \(VLAN\)](#) on page 79

[Viewing LAN Statistics](#) on page 80

[Deactivating LAN Port \(IPBL only\)](#) on page 80

[Configuring a Virtual Local Area Network \(VLAN\)](#) on page 228

[Viewing LAN Statistics](#) on page 80

[Deactivating LAN Port \(IPBL only\)](#) on page 80

Viewing LAN Statistics

About this task

To view statistics of LAN events.

Procedure

1. On a IPBS, select **LAN > Statistics**. On a IPBL, select **LAN1 > Statistics**.

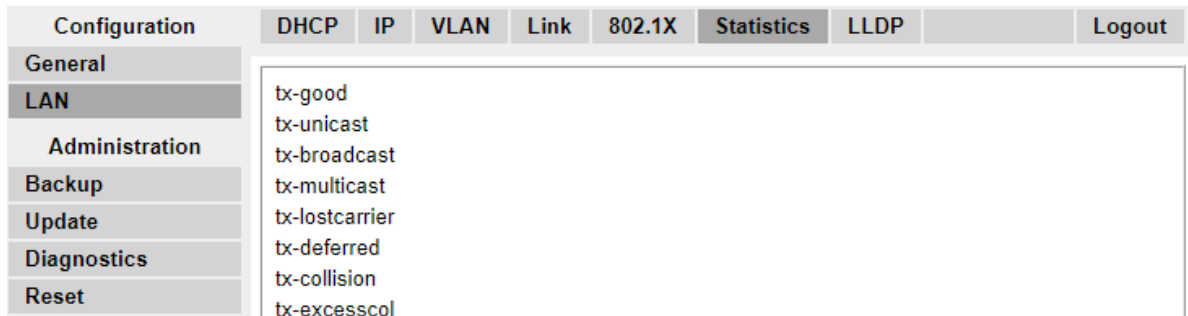

2. Press `Clear` to reset the Ethernet statistics counters. You may need to scroll down to view the **Clear** button.

Related links

[Configuring a VLAN](#) on page 79

[Configuring a VLAN](#) on page 79

Deactivating LAN Port (IPBL only)

About this task

The IP DECT Gateway (IPBL) has two LAN ports. The LAN2 port is used for administration only. If necessary, you can deactivate that port.

Procedure

1. Select **LAN2 > IP**.

Note: The LAN2 port is for administration only. It is typically the port you want to deactivate.

Configuration	System	Suppl. Serv.	Master	Trunks	Radio	Radio config	PARI	SARI	Air Sync	Logout
General										
LAN										
IP										
LDAP										
DECT										
VoIP										
Unite										
Services										
Administration										
Users										
Device Overview										
DECT Sync										
Traffic										

Active Settings

IP Address 192.168.1.1

Network Mask 255.255.255.0

Default Gateway 172.29.40.254

DNS Server

Alt. DNS Server

Check ARP

Disable

No IP protocol data will be sent/received via this interface

2. Select the **Disable** checkbox.
3. Click **OK**.

Related links

- [Configuring a VLAN](#) on page 79
- [Configuring a VLAN](#) on page 79

Updating the Base Station Software

About this task

The base station may need to be upgraded to match the software version supplied for use with the IP Office. The base station software consists of two parts, a firmware file and a boot file. All base stations in a DECT system should use the same version of software.

Procedure

1. Browse into the base station configuration and note the software levels shown by the **Version** line.

Configuration	Info	Admin	EULA	Logout
General				
LAN				
Administration				
Backup				
Update				
Diagnostics				
Reset				

Version IPBS[10.0.5], Bootcode[10.0.5], Hardware[IPBS1-Y4/PD]

Serial Number 09AD15300066

MAC Address (LAN) 00-01-3e-01-6f-9c

DRAM 32 MB

FLASH 8 MB

Coder 8 Channels of G.711,G.729,G.723

SNTP Server 192.168.0.214

Time **..**..**..**

Uptime 0d 1h 38m 42s

2. Check that these match the versions supplied with the IP Office administration software.

Ensure that you are checking against the correct folder for an IPBS1, IPBS2 or IPBS3 base station. If they do not match, you must upgrade the base station.

Master Base Station Setup

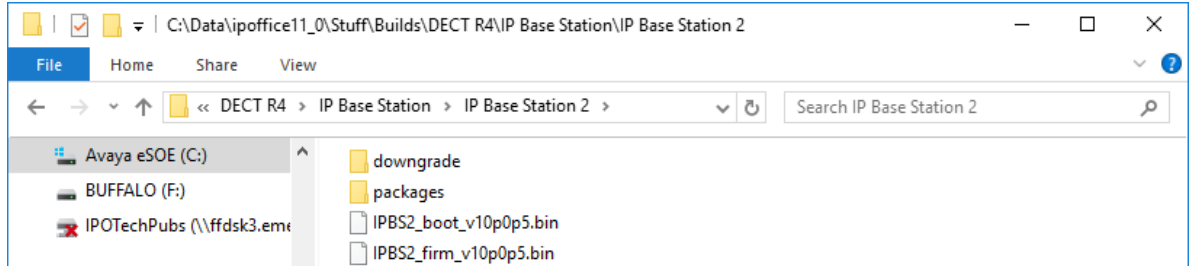

If both software files need to be upgraded, the boot file should be upgraded first.

3. In the left-hand column, under the **Administration** menu, select **Update** and then select the **Boot** tab.

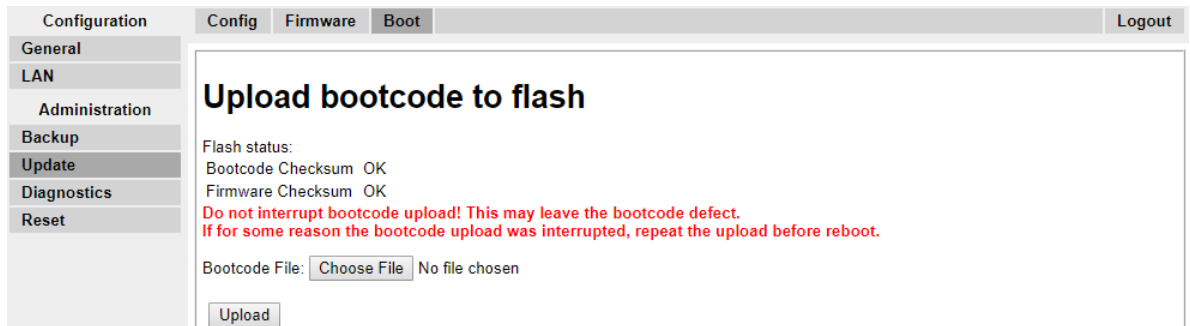

4. Click on the **Browse** button and browse to the **IP Base Station** sub-folder of the Avaya Wireless DECT software.
5. Select the appropriate boot file for the upgrade you are performing.
6. Click **OK**.
7. Click on the **Upload** button.

The browser shows the progress of the upload and upgrade. It will indicate when the process has been completed.



8. If necessary, repeat the process to upgrade remaining base stations.

9. To upgrade the base station firmware file, select **Update** and then select the **Firmware** tab.

10. Click on the **Browse** button and browse to the **IP Base Station** sub-folder of the Avaya Wireless DECT software you previously extracted onto the programming PC.
11. Select the appropriate firmware file for the upgrade you are performing,
12. Click **OK**.
13. Click on the **Upload** button.

The browser shows the progress of the upload and upgrade. It will indicate when the process has been completed.

14. Click on **Reset**.
15. Log in again. The **General > Info** tab should now list the new firmware.

If necessary:

- Repeat the process for the remaining base stations using the **Update > Firmware** menu.
- Update the base station firmware for base stations that will connect to an IP DECT Gateway using the **Update > RFPs** menu.

Related links

[Master Base Station Setup](#) on page 75

Selecting Administration Mode

About this task

On Standard Base Stations, all base station menus and menu options are visible by default, including numerous settings that are not applicable for IP Office operation. Compact Base Stations have advanced options hidden by default. This option is not supported on an IP DECT Gateway.

To enable or disable the advanced administration mode, use the following procedure.

Procedure

1. Select **General | Admin.**

The screenshot shows a configuration window with a sidebar on the left containing menu items: Configuration, General, LAN, Administration, Backup, Update, Diagnostics, and Reset. The main window has tabs for Info, Admin, and EULA, with a Logout button on the far right. The Admin tab is active, displaying the 'Local Admin' section with input fields for Device Name, User Name (pre-filled with 'admin'), Password, Confirm Password, and a text area for Login Banner. Below this is the 'Password Policy' section with numeric input fields for Minimum length (8), Number of character types (2), and Number of previous passwords not allowed (1). There are also two checked checkboxes: 'Do not allow repeated characters' and 'Do not allow sequential characters'. At the bottom, there is an 'Administration Mode' section with a 'Show Advanced Options' checkbox, which is currently unchecked. 'OK' and 'Cancel' buttons are at the bottom of the window.

2. Enable or disable the **Show Advanced Options** checkbox as desired.

This is a close-up of the 'Administration Mode' section from the previous screenshot. It shows a single checkbox labeled 'Show Advanced Options' which is checked. The checkbox is highlighted with a red rectangular border.

3. Click **OK**.

Related links

[Master Base Station Setup](#) on page 75

Selecting Master Mode

About this task

You must configure a base station to act as a master base station and configure the master for the type of telephone system it will be operating with.

Procedure

1. Select **DECT** and then select the **Master** tab.

The screenshot shows a configuration window with a sidebar on the left containing menu items: Configuration, General, LAN, IP, LDAP, and DECT. The main window has tabs for System, Suppl. Serv., Master, Trunks, Radio, Radio config, PARI, SARI, Air Sync, and Logout. The Master tab is active, displaying a 'Mode' dropdown menu currently set to 'Off'. Below the dropdown are 'OK' and 'Cancel' buttons.

2. Change the **Mode** to **Active** and click **OK**. A warning is displayed if the DECT password has not been set. For information on setting the DECT password, see [Set the DECT Password](#) on page 85.
3. Select the **Reset** in the configuration column.
4. Reset the base station.
5. Select **DECT** and then select the **Master** tab again.

Configuration	System	Suppl. Serv.	Master	Trunks	Radio	Radio config	PARI	SARI	Air Sync	Logout
General										
LAN										
IP										
LDAP										
DECT										
VoIP										
Unite										
Services										
Administration										
Users										
Device Overview										
DECT Sync										
Traffic										

Mode Active ▼

IP-PBX

PBX IPO ▼

PBX Resiliency

Protocol H.323/XMobile ▼

ARS Prefix

International CPN Prefix

National CPN Prefix

reset required

6. Change the **PBX** setting to **IPO** and click **OK**.
7. Select **Reset** in the configuration column.
8. Reset the base station.

Related links

[Master Base Station Setup](#) on page 75

Setting the DECT Password

About this task

The DECT system name and password are used by other base stations to connect to the master. The name also appears in other menus and on phone displays.

Procedure

1. Select **DECT** and then select the **System** tab.

Configuration	System	Suppl. Serv.	Master	Trunks	Radio	Radio config	PARI	SARI	Air Sync	Logout
General										
LAN										
IP										
LDAP										
DECT										
VoIP										
Unite										
Services										
Administration										
Users										
Device Overview										
DECT Sync										
Traffic										
Backup										
Update										
Diagnostics										
Reset										

System Name	<input type="text" value="IPBS2"/>
Password	<input type="password" value="••••••"/>
Confirm Password	<input type="password" value="••••••"/>
Subscriptions	<input type="text" value="With System AC"/> ▼
Authentication Code	<input type="text" value="50428950"/>
Default Language	<input type="text" value="English"/> ▼
Frequency	<input type="text" value="1880-1900 MHz (Europe)"/> ▼
Enabled Carriers	9 8 7 6 5 4 3 2 1 0 <input checked="" type="checkbox"/> <input checked="" type="checkbox"/> <input checked="" type="checkbox"/> <input checked="" type="checkbox"/> <input checked="" type="checkbox"/> <input checked="" type="checkbox"/> <input checked="" type="checkbox"/> <input checked="" type="checkbox"/> <input checked="" type="checkbox"/> <input checked="" type="checkbox"/>
Early Encryption	<input type="checkbox"/>
Coder	<input type="text" value="G729A"/> ▼ Frame (ms) <input type="text" value="30"/> Exclusive <input type="checkbox"/> SC <input type="checkbox"/>
Secure RTP Key Exchange	<input type="text" value="No encryption"/> ▼
<input type="button" value="OK"/> <input type="button" value="Cancel"/>	

reset required

2. Enter and confirm the password you want to use.
3. The **Subscriptions** and **Authentication Code** fields should not be adjusted. These will be set by the IP Office once the base station is in provisioning mode.
4. Check that the DECT **Frequency** field is set correctly for your location.
5. Click **OK**.

Related links

[Master Base Station Setup](#) on page 75

Setting the Time Zone

About this task

During a provisioned installation, Network Time Protocol (NTP) settings are all greyed out as the IP Office is automatically set as the time server. If you do not set the time zone prior to provisioning, the time and date on all the sets will be incorrect.

Procedure

1. Select **General** and then select the **NTP** tab.

Configuration	Info	Admin	NTP	Kerberos Server	Certificates	EULA	Logout
General							
LAN							
IP							
LDAP							
DECT							
VoIP							
Unite							
Services							
Administration							
Users							
Device Overview							

		Active Settings
Time Server	<input type="text" value="192.168.0.50"/>	192.168.0.50
Alt. Time Server	<input type="text"/>	
Interval [min]	<input type="text" value="60"/>	60
Timezone	<input type="text" value="Europe - Central European Time (UTC+1)"/> ▼	
String	<input type="text" value="CET-1CEST-2,M3.5.0/2,M10.5.0/3"/>	CET-1CEST-2,M3.5.0/2,M10.5.0/3
Current Server	192.168.0.50 -> 192.168.0.50	
Last Sync		
<input type="button" value="OK"/> <input type="button" value="Cancel"/>		

2. Using the **Timezone** drop-down menu, select the appropriate time zone for your area.
3. Click **OK**.

Related links

[Master Base Station Setup](#) on page 75

Enabling Provisioning

About this task

You can now configure the master base station for IP Office provisioning. Once you have enabled provisioning, several fields of the base station configuration will be set by the IP Office system. Other fields are greyed out and or automatically set to the values required for IP Office operation.

Before enabling IP Office provisioning, ensure that you configure the time zone. Otherwise, the time and date on all sets will be incorrect, as the IP Office is automatically set as the time server.

Procedure

1. Select **Services** and then select the **Provisioning** tab. This tab is only available when the base station's **Master** setting is **Active** and the **PBX** setting is set to **IPO** (see [Select Master Mode](#) on page 84).

Configuration	Update	Logging	HTTP	HTTP Client	SNMP	Provisioning	Phonebook	Logout
General								
LAN								
IP								
LDAP								
DECT								
VoIP								
Unite								
Services								
Administration								
Users								
Device Overview								
DECT Sync								
Traffic								
Backup								
Update								
Diagnostics								
Reset								

Current view Primary
Enable <input checked="" type="checkbox"/> Use HTTPS <input checked="" type="checkbox"/> PBX IP Address <input type="text" value="192.168.0.210"/>
General HTTP settings Base directory <input type="text" value="/system/ipdect/"/> User Name <input type="text" value="IPDECTService"/> Password <input type="password" value="*****"/>
Update service sub directory and file name Command File <input type="text" value="update_service"/>
Provisioning sub directory and file name System data <input type="text" value="system_data"/> User data <input type="text" value="extension_data?id="/>
Status Inactive
<input type="button" value="OK"/> <input type="button" value="Cancel"/>

2. Select the **Enable** option.
3. The IP Office security settings control whether HTTPS is supported between the IP Office control unit and the master base station (by default it is supported). To configure the IP DECT to use both self-signed certificates and approved certificates from a trusted location, enable the **Use HTTPS** checkbox and refer to [Security Settings](#) on page 65.
4. Set the **PBX IP Address** to match the IP Office system on which the IP DECT line was configured.
5. In the User Name and Password fields, set the details to match the IP Office system's service user configured for IP DECT. See [Security Settings](#) on page 65.
6. Click **OK**.
7. Reset the base station.
8. Select the **Services | Provisioning** tab again. The Status should have changed to **Connected**. If not, a user name/password mismatch may have caused the IP Office service user account to become disabled, check the settings and re-enable the user.
9. Select **DECT | SARI**. The value of the SARI entered into the IP Office configuration should now also be visible in the base station configuration.
10. Select **DECT | System**.

Related links

[Master Base Station Setup](#) on page 75

Enabling HTTPS and Security Certificates in the Web Interface

About this task

Depending on your site configuration, you may need to enable provisioning in the device configuration so that the IP DECT allows both self-signed certificates and approved certificates from a trusted location. You can also configure this option in IP Office Manager. See [Enabling HTTPS and Security Certificates in IP Office Manager](#) on page 65.

Procedure

1. Begin by enabling the advanced view in the Web Interface. Refer to [Select Administration Mode](#) on page 83.
2. Ensure that HTTPS provisioning is enabled.
3. Save the configuration and reset the device.
4. Select **General | Certificates** and wait to see the certificate from IP Office appear in the **Not trusted** list.

The screenshot shows the 'Certificates' configuration page in the IP Office Web Interface. The left sidebar contains a navigation menu with options like Configuration, LAN, IP, LDAP, DECT, VoIP, Unite, Services, Administration, Users, Device Overview, DECT Sync, and Traffic. The main content area has tabs for Info, Admin, NTP, Kerberos Server, Certificates, EULA, and Logout. Under the 'Certificates' tab, there are sections for 'Trust List' (with a 'File' upload field and 'Upload' button), 'Device Certificate' (with a table of certificates), and a 'Password' field with another 'File' upload field. The 'Device Certificate' table has columns for Subject, Issuer, Not before, Not after, and Download. A 'Trust' button is visible below the table.

Subject	Issuer	Not before	Not after	Download
<input type="checkbox"/> 00-01-3e-12-86-81	00-01-3e-12-86-81	01.01.2000	31.12.2049	PEM DER

5. Under **Rejected Certificates**, select the desired certificate from the **Not trusted** list and press the **Trust** button.

The screenshot shows the 'Rejected Certificates' section, which is currently empty. Below the section title, there is a 'Not trusted' list. A single certificate is listed with a checked checkbox and the subject 'ipoffice-00e007063082.avaya.com'. Below the list, there are 'Trust' and 'Clear' buttons. The 'Trust' button is highlighted with a red box.

The certificate should now appear in the **Trust List** section. No reset is required.

Related links

[Master Base Station Setup](#) on page 75

Adding Radio Connections

About this task

Each base station has a radio interface that must connect with the master base station. That includes the master base station’s own radio interface.

Procedure

1. Select **Device Overview** and then select the **Radios** tab.

2. The list shows those base stations the master can detect. Click **Add**.
3. On the popup window that appears, click **OK**.
4. Wait for the **Radios** tab to refresh. Note that this can take a couple of minutes.

Related links

[Master Base Station Setup](#) on page 75

Phonebook Integration

About this task

In a provisioned installation, the phonebook settings are automatically set by the IP Office system. However, use of the IP Office users, groups and directory as part of the DECT phone directory still needs to be enabled if required. If not enabled, the Central Phonebook functions on the DECT phones will not work.

For DECT systems using an AIWS, central phone book provisioning is done via the AIWS. (see [Enable Base Station AIWS Connection](#) on page 205).

Procedure

1. Select **Services**.
2. Select **Phonebook**.
3. Select **Enable**.

The screenshot shows the configuration interface for the Phonebook. The left sidebar contains a navigation menu with options: Configuration, Provisioning, Phonebook, and Logout. The main content area is titled 'Phonebook' and includes an 'Enable' checkbox which is checked. Below this are two sections: 'General Settings' and 'TFTP Settings'. In the 'General Settings' section, there is a 'Search Direction Numbers' dropdown menu set to 'Right to left' and a 'Phonebook Number' text input field containing '999999'. In the 'TFTP Settings' section, there is a 'Server IP Address' text input field containing '192.168.0.210'. At the bottom of the form are 'OK' and 'Cancel' buttons.

4. Click **OK**.

Related links

[Master Base Station Setup](#) on page 75

Performing an RFP Scan

About this task

The following processes are only required if the DECT system is operating in the same area as other DECT systems.

The Primary Access Rights Identifier (PARI) is a part of the IPBS broadcast identity, which uniquely identifies each DECT system. This PARI is automatically assigned to each master in the system. However, if more than one DECT system operates within the same coverage area, each system need to have a unique PARI assigned in order to differentiate the systems.

To see the occupied system IDs of other Avaya IP-DECT systems within the coverage area, perform an RFP scan using the following procedure:

Procedure

1. Select **Diagnostics**
2. Select **RFP Scan**
3. Click **Start Scanning**

*** Note:**

Executing an RFP scan will terminate all calls on the IPBS.

Related links

[Master Base Station Setup](#) on page 75

[Configuring the Master Base Station](#) on page 220

Entering the PARI

About this task

The following processes are only required if the DECT system is operating in the same area as other DECT systems. Following a RFP scan, ensure that the master base station has a unique Primary Access Rights Identifier (PARI) to identify it and the DECT system.

Procedure

1. In the left-hand panel select **DECT**. Select the **PARI** tab.



The screenshot shows a configuration window with a left-hand navigation pane and a main content area. The navigation pane has a 'Configuration' header and several sub-items: General, LAN, IP, LDAP, and DECT. The 'DECT' item is selected. The main content area has a horizontal tab bar with the following tabs: System, Suppl. Serv., Master, Trunks, Radio, Radio config, PARI, SARI, Air Sync, and Logout. The 'PARI' tab is selected. Below the tab bar, there is a 'System ID' label followed by a text input field containing the number '30'. Below the input field are two buttons: 'OK' and 'Cancel'.

2. Enter a value between 1 and 35. This value must be unique from any other Avaya Wireless DECT master base station in the area.
3. Click **OK**.

Related links

[Master Base Station Setup](#) on page 75

Configuring Air Sync

About this task

The following process is only required if the DECT system is operating in the same area as other DECT systems or the position of the master base station means it cannot be used as the air sync master for all the other base stations.

Base stations in the Avaya Wireless DECT system need to be synchronized with each other. This can be done with a signal as low as -90dB between base stations.

One base station is assigned as the 'air sync master', typically the master base station. Each other base station can sync directly with it or indirectly via a synchronization chain. However, it is preferable that the number of synchronization 'hops' between any particular base station and its air sync master base station is kept as low as possible. To help achieve this it is recommended that the air sync master is placed centrally within the set of base stations.

Where possible, each base station should be placed within synchronization range of more than one base station, which allows the base stations to maintain synchronization should one base station fail or be switched off for maintenance. The process of synchronizing by the shortest route to the air sync master when in synchronization range of multiple base stations is automatic.

Procedure

1. In the left-hand panel, select **DECT**. Select the **Air Sync** tab.

The screenshot shows the configuration interface for the Avaya Wireless DECT system. On the left, a navigation pane lists various configuration categories: Configuration, General, LAN, IP, LDAP, DECT (highlighted), VoIP, Unite, Services, Administration, Users, and Device Overview. The main configuration area has several tabs: System, Suppl. Serv., Master, Trunks, Radio, Radio config, PARI, SARI, Air Sync (selected), and Logout. The 'Air Sync' tab is active, displaying the following settings:

- Sync Mode: Master (dropdown menu)
- Reference RFPI: [Empty text box]
- Alternative reference RFPI: [Empty text box]
- Sync Region: 0 (text box)
- Action at reference sync failure:
 - Resynchronize on command
 - Resynchronize every day at 00:00 (dropdown)
 - Resynchronize every Sunday (dropdown) at 00:00 (dropdown)

At the bottom of the configuration area are 'OK' and 'Cancel' buttons.

2. Set the **Sync Mode** to **Master**.
3. Click **OK**.

Related links

[Master Base Station Setup](#) on page 75

Advanced Scenario: Separated Locations

In most scenarios, the master base station (Standard or Compact) is also used as the air sync master for all the other slave base stations and that is the scenario documented in this manual. However, in scenarios where you have base stations in separate locations that are not within

synchronization range of each other, it is permissible to assign separate air sync masters in each location. However, there must be absolutely no overlap (<-90dB) between the separate groups of base stations. Any overlap will cause frequent loss of synchronization.

Having separate locations, each with its own synchronization, is done through the settings on the **DECT | Air Sync** tab of each base station. For each location, set the same **Sync Region** number for all the base stations at that location, using a different number for each location. In addition, use the **Sync Mode** drop-down menu to configure one of the base stations in each location as the **Master** base station.

 **Note:**

In deployments in mixed systems with IP Base Stations and IP-DECT Gateways, the IP-DECT Gateways need to be physically interconnected for the purpose of radio synchronization. When configuring an IP-DECT Gateway as an air sync master, use sync region 0. All other base stations should be configured as sync slaves. Systems with IPBS in sync regions that have only IPBS should use non-zero sync region number(s) and be configured with at least one sync master with the remaining IPBSs configured as sync slaves.

Related links

[Site Survey and Planning](#) on page 52

[Master Base Station Setup](#) on page 75

[Configuring Air Sync in Separated Locations](#) on page 94

[Configuring Air Sync](#) on page 238

[Configuring Air Sync in Separated Locations](#) on page 94

Configuring Air Sync in Separated Locations

Procedure

1. For each base station in the system, configure a **Sync Region** number under the **DECT | Air Sync** tab in the Device Manager and click **OK**.

All the base stations in a single region should contain the same **Sync Region** number, but each Sync Region must have its own unique number. By default, **Sync Region = 0**, which means that no region is defined.

2. For each new Sync Region created, configure one base station as the **Master** using the **Sync Mode** drop-down menu and click **OK**.

You must configure at least one master base station per region.

Configuration	System	Suppl. Serv.	Master	Trunks	Radio	Radio config	PARI	SARI	Air Sync	Logout
General										
LAN										
IP										
LDAP										
DECT										
VoIP										
Unite										
Services										
Administration										
Users										
Device Overview										

Sync Mode	Master
Reference RFPI	
Alternative reference RFPI	
Sync Region	1
Action at reference sync failure	<input checked="" type="radio"/> Resynchronize on command <input type="radio"/> Resynchronize every day at 00:00 <input type="radio"/> Resynchronize every Sunday at 00:00
<input type="button" value="OK"/> <input type="button" value="Cancel"/>	

Related links

[Advanced Scenario: Separated Locations](#) on page 56

[Advanced Scenario: Separated Locations](#) on page 56

Chapter 10: IP Slave Base Station Setup

Once you have completed the setup of the DECT master base station, proceed to configure the slave base stations for the system.

Related links

- [Defaulting the Base Station](#) on page 96
- [Accessing the Base Station Configuration](#) on page 97
- [Setting the Base Station IP Address](#) on page 98
- [Updating the Base Station Software](#) on page 99
- [Setting a Base Station to Slave Mode](#) on page 101
- [Registering the Slave Base Station](#) on page 103

Defaulting the Base Station

About this task

This process will default a base station or IP DECT Gateway, erasing its configuration. After the unit restarts it will default to the IP address 192.168.0.1/255.255.255.0.

Note:

The following instructions assume you are installing an IPBS2/IPBS3, which has one LED lamp. The IPBS1 has two LED lamps. For more information on the base station LEDs and what their statuses indicate, see [Base Station Status Lamps](#) on page 22.

Procedure

1. With only the power supply connected, switch the base station on.
The LED on the base station flashes red if no Ethernet is detected.
2. Wait approximately five seconds.
3. Press and hold the **Reset** button on the base station for approximately 10 seconds..
The LED on the base station will change to a quick flash, then the LED will go out, and then the LED returns to a slower flash.
4. Release the **Reset** button and wait for the base station to reset.
The LED should turn back on to solid amber.

5. Quickly press the **Reset** button once.

The base station reboots with default settings. The default IP is 192.168.0.1, with DHCP on, but not active. If you wish to activate DHCP reset the base station again.

*** Note:**

Avaya recommends disabling the DHCP on the base station and configuring the system with static IP addresses. For information on disabling DHCP on the base station, see [Set the Base Station IP Address](#) on page 78.

Related links

[IP Slave Base Station Setup](#) on page 96

Accessing the Base Station Configuration

Procedure

Depending on whether DHCP is being used or not:

- a. Connect the base station to the network or PC using the LAN cable.
- b. If connected directly to the base station, change your programming PC's network address to 192.168.0.200 with subnet mask 255.255.255.0.
- c. If both your PC and the base station are connected to a LAN network with DHCP server, ensure your PC is set to act as a DHCP client or has a fixed address that is valid on the network.
- d. Start your web browser and enter the http:// or https:// followed by the IP address of the base station. The default IP address is 192.168.0.1. If a security certificate warning is displayed, select to continue to this website.
- e. The base station responds with its login menu.

- f. Select **System administration**. Enter the default user name (**admin**) and password (**changeme**) and click **Login**.
- g. A summary of the current logins is displayed. Click **OK**.
- h. The configuration menu for the base station is displayed.

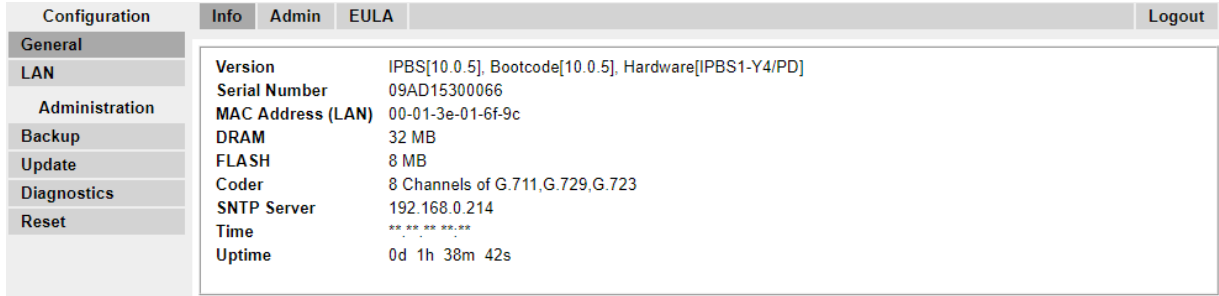

- i. Note the software levels shown in the **General | Info** menu. These will determine if the base station software needs to be upgraded.

*** Note:**

Compact Base Stations have advanced menu options hidden by default. To enable or disable Advanced Administration menus, see [Select Administration Mode](#) on page 83 .

Related links

[IP Slave Base Station Setup](#) on page 96

Setting the Base Station IP Address

About this task

During initial installation the IP address of a base station defaults to 192.168.0.1. The process below can be used to change the DHCP mode and IP address of a base station.

Procedure

1. From the base station configuration window, in the left-hand column, select **LAN**.
2. Select the **IP** tab.

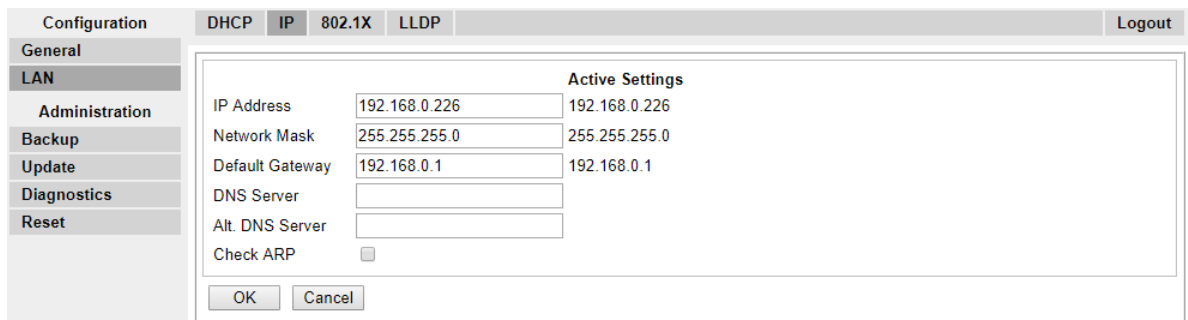

- a. Enter the required **IP Address** and **Network Mask** for the base station. The other settings are optional.
- b. Click **OK**.

*** Note:**

The menu will prompt you with the message **Reset Required**. Do not click this or reset the base station at this stage.

- c. Select the **DHCP** tab.

Configuration	DHCP	IP	802.1X	LLDP	Logout
General	Mode disabled <input type="button" value="Currently - disabled"/> <input type="button" value="OK"/> <input type="button" value="Cancel"/>				
LAN					
Administration					
Backup					

- d. Using the **Mode** drop-down, select **Disabled**.
- e. Click **OK**.
- f. Select **Reset** and then select the **Reset** tab.
- g. Click **OK**.
- h. Depending on your base station, wait for the LED to return to solid blue or solid green.
- i. Log in again using the new IP address.

Related links

[IP Slave Base Station Setup](#) on page 96

Updating the Base Station Software

About this task

The base station may need to be upgraded to match the software version supplied for use with the IP Office. The base station software consists of two parts, a firmware file and a boot file. All base stations in a DECT system should use the same version of software.

Procedure

1. Browse into the base station configuration and note the software levels shown by the **Version** line.

Configuration	Info	Admin	EULA	Logout
General	Version IPBS[10.0.5], Bootcode[10.0.5], Hardware[IPBS1-Y4/PD] Serial Number 09AD15300066 MAC Address (LAN) 00-01-3e-01-6f-9c DRAM 32 MB FLASH 8 MB Coder 8 Channels of G.711,G.729,G.723 SNTP Server 192.168.0.214 Time ** ** ** ** Uptime 0d 1h 38m 42s			
LAN				
Administration				
Backup				
Update				
Diagnostics				
Reset				

2. Check that these match the versions supplied with the IP Office administration software.

Ensure that you are checking against the correct folder for an IPBS1, IPBS2 or IPBS3 base station. If they do not match, you must upgrade the base station.

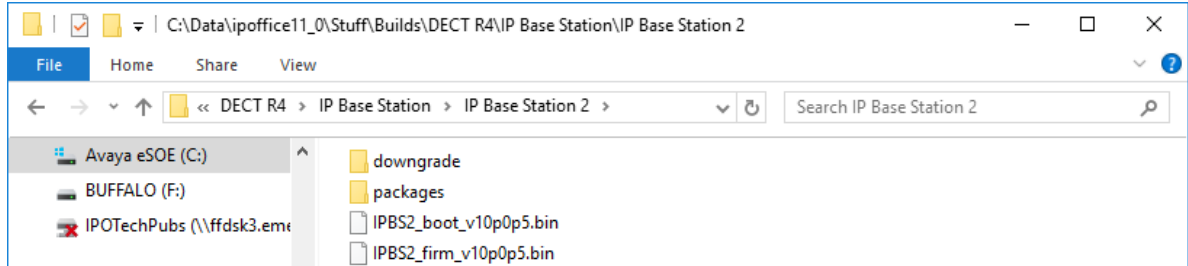

If both software files need to be upgraded, the boot file should be upgraded first.

3. In the left-hand column, under the **Administration** menu, select **Update** and then select the **Boot** tab.

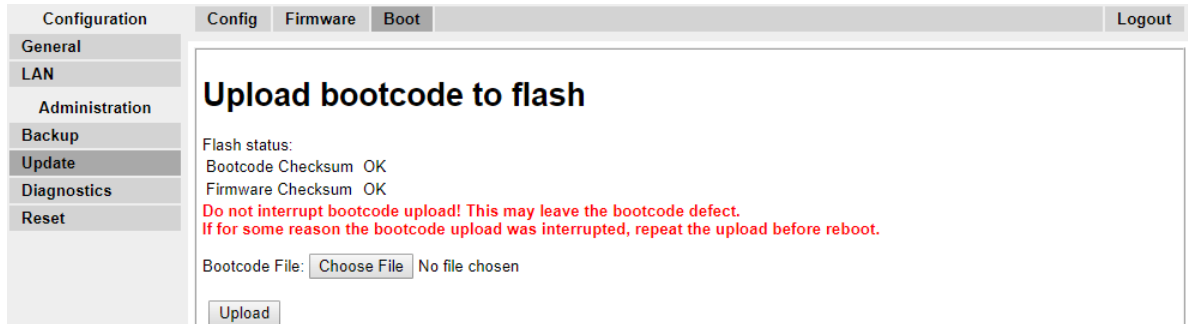

4. Click on the **Browse** button and browse to the **IP Base Station** sub-folder of the Avaya Wireless DECT software.
5. Select the appropriate boot file for the upgrade you are performing.
6. Click **OK**.
7. Click on the **Upload** button.

The browser shows the progress of the upload and upgrade. It will indicate when the process has been completed.



8. If necessary, repeat the process to upgrade remaining base stations.

9. To upgrade the base station firmware file, select **Update** and then select the **Firmware** tab.

10. Click on the **Browse** button and browse to the **IP Base Station** sub-folder of the Avaya Wireless DECT software you previously extracted onto the programming PC.
11. Select the appropriate firmware file for the upgrade you are performing,
12. Click **OK**.
13. Click on the **Upload** button.

The browser shows the progress of the upload and upgrade. It will indicate when the process has been completed.

14. Click on **Reset**.
15. Log in again. The **General > Info** tab should now list the new firmware.

If necessary:

- Repeat the process for the remaining base stations using the **Update > Firmware** menu.
- Update the base station firmware for base stations that will connect to an IP DECT Gateway using the **Update > RFPs** menu.

Related links

[IP Slave Base Station Setup](#) on page 96

Setting a Base Station to Slave Mode

About this task

There can be only one master base station in the IP Office Avaya Wireless DECT system. In this process we check that the base station is not set to act as a master and then configure its radio settings to access the master base station.

Procedure

1. In the left-hand column, select **DECT**. Select the **Master** tab.

The screenshot shows the configuration interface with the 'Master' tab selected. The 'Mode' is set to 'Off'. The interface includes a 'Configuration' sidebar on the left and a main content area with 'OK' and 'Cancel' buttons.

2. Check that the **Mode** is set to **Off**.
3. Click **OK**.
4. Select the **Radio** tab.

The screenshot shows the 'Radio' configuration tab. It includes a 'Disable' checkbox, a 'Master' section with fields for Name, Password, Master IP Address, and Alt. Master IP Address, and a 'Status' field. Below this is a 'Max RTP Streams' section with a 'Number of Streams' field. The 'Received Configuration' section lists various parameters like SARI, RFPI, Subscriptions, Authentication Code, Default Language, Frequency, Enabled Carriers, Early Encryption, ICE, and Coder. 'OK' and 'Cancel' buttons are at the bottom.

5. Set the following details:

- **Name**

Set this to match the **System Name** set on the master base station's **DECT | System** tab.

- **Password**

Set this to match the **Password** set on the master base station's **DECT | System** tab.

- **Master IP Address**

Enter the IP address of the master base station set on its **LAN | IP** tab.

- Click **OK**.
- Select the **Air Sync** tab.

The screenshot shows a configuration window with a sidebar on the left containing tabs: Configuration, System, Suppl. Serv., Master, Trunks, Radio, Radio config, PARI, SARI, Air Sync, and Logout. The 'Air Sync' tab is selected. The main area contains the following fields:

- Sync Mode: Slave (dropdown menu)
- Sync RFPI: [Empty text box]
- Alternative sync RFPI: [Empty text box]
- Sync Region: 0 (text box)
- Buttons: OK, Cancel

- Set the **Sync Mode** to **Slave**.
- Click **OK**.

Related links

[IP Slave Base Station Setup](#) on page 96

Registering the Slave Base Station

About this task

The slave base station needs to register and be synchronized with the master base station. Use the master base station configuration to register the slave base station.

*** Note:**

The following instructions assume you are installing an IPBS2/IPBS3 , which has one LED lamp. The IPBS1 has two LED lamps. For more information on the base station LED's and what their statuses indicate, see [Base Station Status Lamps](#) on page 22.

Procedure

1. Login to the master base station.
2. Select **Device Overview** and then select the **Radios** tab.

The screenshot shows the 'Radios' configuration page. It features a sidebar with tabs: Configuration, Radios, and Logout. The main content area is divided into two sections:

- Static Registrations:** A table with columns: Name, RFPI, IP Address, Sync, Region, Device Name, Version, and Connected. One entry is shown: IPBS2-12-87-b1, RFPI 9015001008, IP Address 192.168.42.151, Master OK, Region 9, Device Name IP-DECT Base Station [11.5.11/11.5.11/IPBS2-C4/1A], Version [11.5.11/11.5.11/IPBS2-C4/1A], Connected 12d 21h 9r.
- Uninitialized Registrations:** A table with columns: Name, IP Address, Device Name, Version, and Connected Time. One entry is shown: IPBS-01-6f-9c, IP Address 192.168.0.226, Device Name IP-DECT Base Station, Version [10.0.5/10.0.5/IPBS1-Y4/PD], Connected Time 0d 0h 0m 26s. An 'Add' button is next to the entry.

The new slave base station is shown as an unregistered device.

3. Click on **Add**.
4. On the pop-up menu that appears, click **OK**.

IP Slave Base Station Setup

The slave base station will be listed as a registered device.

Configuration		Radios							Logout
General									
Static Registrations									
Name ↑	RFPI	IP Address	Sync	Region	Device Name	Version	Connected		
IPBS2-12-87-b1	9015001008	192.168.42.151	Master OK	9	IP-DECT Base Station [-/2022-02-01T10:23:23]	[11.5.11/11.5.11/IPBS2-C4/1A]	12d 21h 9r		
IPBS-01-6f-9c	9015001000	192.168.0.226	Slave OK	0	IP-DECT Base Station	[10.0.5/10.0.5/IPBS1 Y4/PD]	0d 0h 2m		
Import location id's									
Radios: 2, Registrations: 2									

* Note:

It can take up to two minutes for a slave base station to synchronize with the master base station. During this time, the LED flashes fast blue and the status shows **Not in sync**. Once in sync, the LED changes to blue with a yellow flash and the status changes to **OK**.

Related links

[IP Slave Base Station Setup](#) on page 96

Chapter 11: Base Station Mounting

The base station can now be powered down and mounted in its intended operating position. The removable bracket on the back of the base stations can be used for either wall mounting using two screws suitable for the surface or for mounting on columns using two metal bands.

Related links

[Mounting a Base Station using a Wallmount](#) on page 105

[Mounting a Base Station on a Column/Pillar](#) on page 107

Mounting a Base Station using a Wallmount

About this task

Remove the mounting bracket from the base station. Use it as a template for marking the screw fixing holes. Note the diagram below indicating the required clearance for attaching the base station onto the mounting bracket.

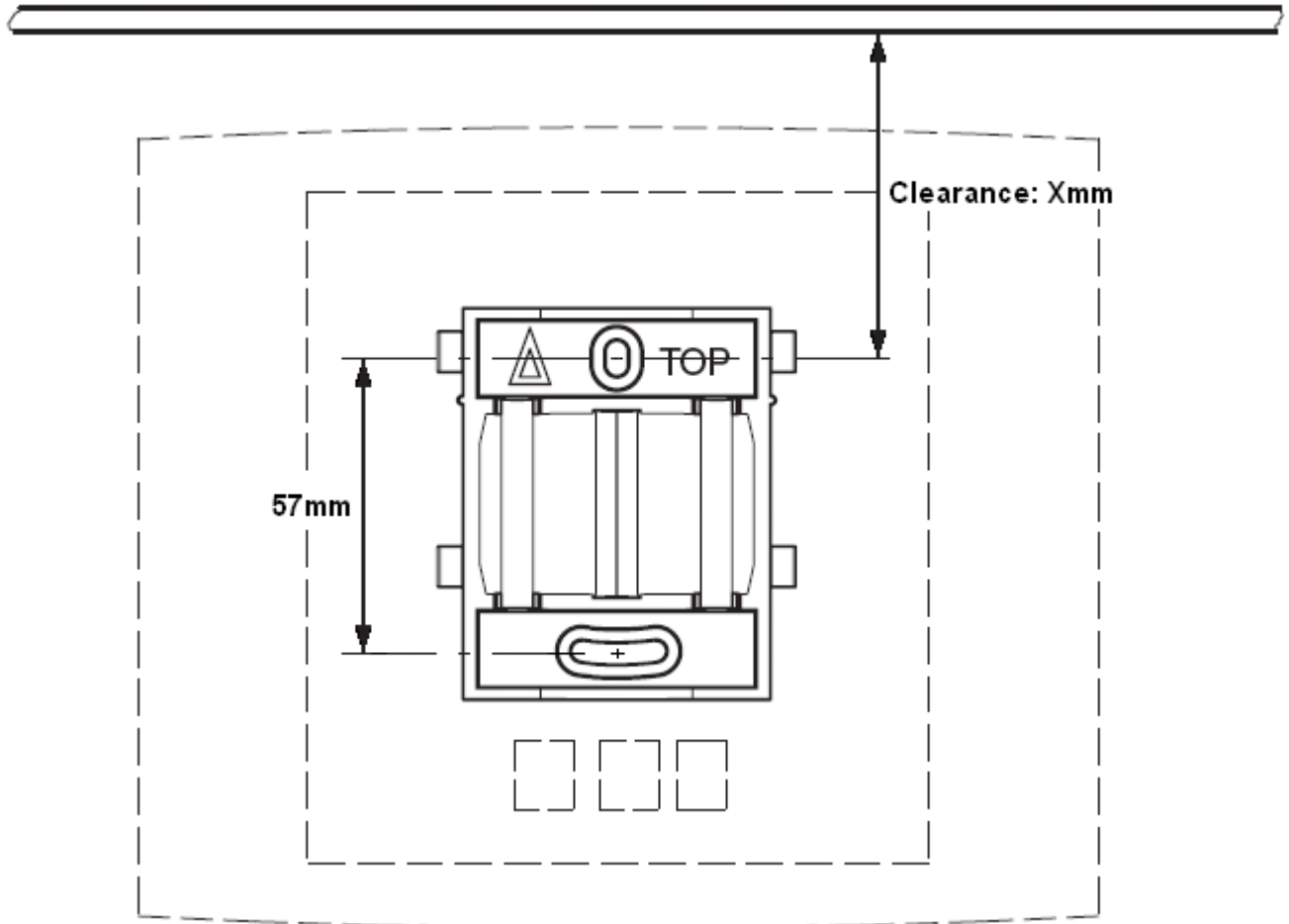

Procedure

1. Hold the mounting bracket with its flat side against the wall with the text ‘TOP’ upwards and mark the two holes. Observe the minimum distance between the top screw hole and the ceiling. This depends on the base station type as follows:

Base Station Type	Internal Aerials	External Aerials
IPBS1 Digital Base Station	65mm	160mm
IPBS2/IPBS3	100mm	195mm

2. Drill the two holes using a 6mm diameter drill and insert the included wall plugs.
3. Position the mounting bracket with its flat side to the wall and fasten it with the two included 3.5mm diameter screws.

Related links

- [Base Station Mounting](#) on page 105
- [Mounting](#) on page 143
- [Mounting a Base Station](#) on page 255

Mounting a Base Station on a Column/Pillar

The mounting bracket can be fixed to a pole of 45mm diameter or greater, or a beam of 50mm width minimum by using a strap or flexible metal band less than 30 mm wide. A suitable strap or flexible metal band is not included with the base station.

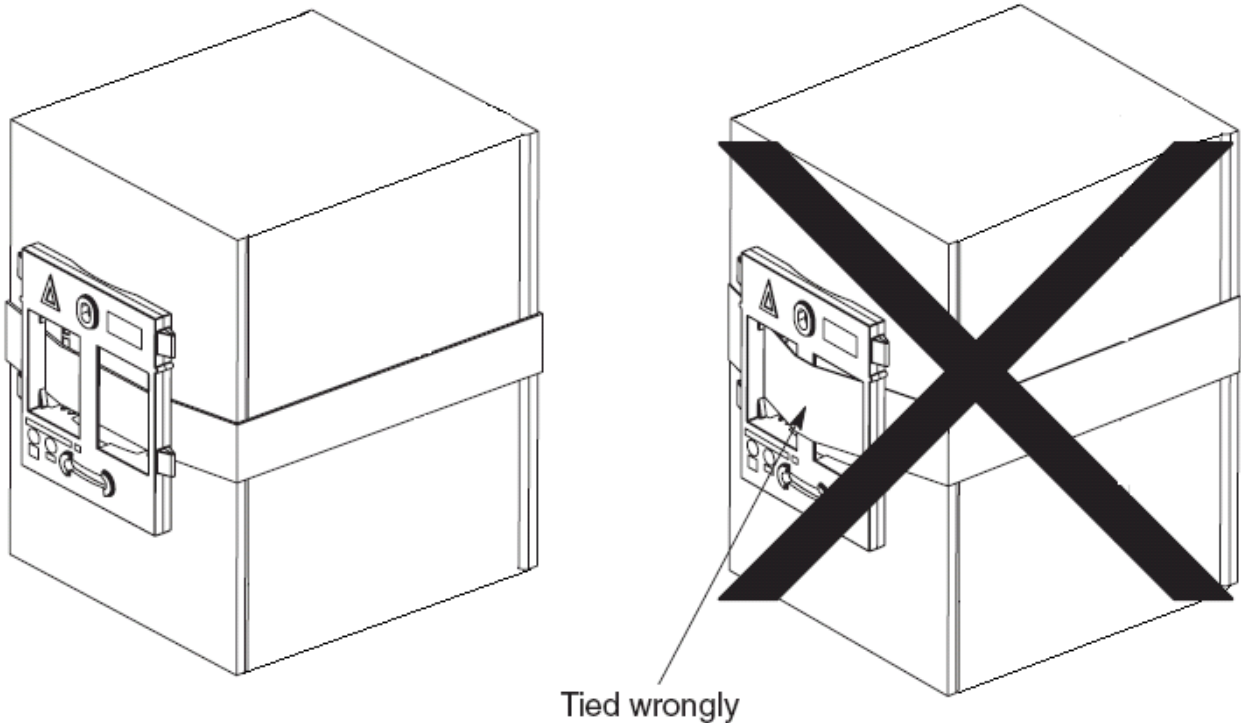

Note: Mounting a wireless base station directly on a steel beam or pillar could result in signal disruptions, such as dead zones or reflections. If it is absolutely necessary to mount the base station on a metallic surface, use spacers to separate the base station from the surface by 20-25 cm.

Related links

[Base Station Mounting](#) on page 105

[Mounting](#) on page 143

[Mounting a Base Station](#) on page 255

Chapter 12: Subscribing Phones

Once the master base station has been configured and is connected to the IP Office, you can begin phone subscription.

There are two methods of phone subscription; **pre-configured** or **auto-create**.

- The **pre-configured** method requires the DECT users to be pre-configured in the master base station configuration.
- The **auto-create** method does not require users to be pre-configured if the auto-create users checkbox is enabled in the IP-DECT Line, Gateway tab.

In both cases, the IP Office configuration should also contain available Avaya IP Endpoint Licenses. The PARK code and Authentication Code of the Avaya Wireless DECT system are required during subscription. The values set on the IP DECT line in the IP Office configuration are used.

Note:

This method makes changes to the IP Office system configuration. Ensure that no copies of the configuration are open in Manager during subscription as sending that configuration back to the IP Office system will remove the subscriptions and require the handsets to be resubscribed.

Related links

[Preconfigured Phone Subscription](#) on page 108

[Auto-Create Phone Subscription](#) on page 109

[Allowing Subscription](#) on page 109

[Manually Creating Extensions](#) on page 112

[Subscribing a Phone](#) on page 113

[Upgrading Phones](#) on page 117

[Displaying Subscribed Users](#) on page 122

[Unsubscribing Phones](#) on page 123

[Disabling Subscription](#) on page 124

Preconfigured Phone Subscription

About this task

This method is used when the IP Office IP DECT line's **Subscriptions** setting is set to **Preconfigured**. The SARI and Authentication Code set in the IP Office configuration are used.

Using this method, entries for the IP DECT extensions and users must first be created in the IP Office configuration. The matching phones can then be subscribed.

Procedure

1. Set the IP DECT line's **Subscriptions** mode to **Preconfigured**.
2. Create an IP DECT extension and user entry for each phone.
3. Subscribe the phones.
4. Disable subscription when all phones have been subscribed.

Related links

[Subscribing Phones](#) on page 108

Auto-Create Phone Subscription

About this task

This method is used when the IP Office IP DECT line's **Subscriptions** setting is set to **Auto-Create**. After successfully subscribing, the phone is assigned a temporary extension number which is the highest existing extension number plus 1.

You can accept this number or assign the desired extension number.

Procedure

1. Set the IP DECT line's **Subscriptions** mode to **Auto-Create**. Ensure that the **Auto-Create User** and **Auto-Create Extension** options are also selected.
2. Subscribe the phone to a temporary extension number.
3. Accept the temporary extension number (*#) or enter an alternate extension number (XXX*LLL#).

XXX is the extension number to use and LLL is the Login Code to assign to the user.
4. Disable subscription when all phones have been subscribed.

Related links

[Subscribing Phones](#) on page 108

Allowing Subscription

Before phones are subscribed, subscription needs to be allowed by both the IP Office and the Avaya Wireless DECT system.

Related links

[Subscribing Phones](#) on page 108

[Enabling IP Office Subscription](#) on page 110

[Master Base Station](#) on page 111

Enabling IP Office Subscription Procedure

1. Start IP Office Manager and receive the configuration from the IP Office system.
2. In the left-hand navigation pane, click on **Line** icon.
3. Select the **IP DECT Line**.
4. Select the **Gateway** tab.

The screenshot shows the configuration interface for a line, with the 'Gateway' tab selected. The interface includes several sections:

- Line** (selected), **Gateway**, **VoIP**
- Auto-Create Extension**
- Auto-Create User**
- Enable DHCP Support**
- Boot File**: ADMM_RFP_1_1_13.tftp
- ADMM MAC Address**: 00 00 00 00 00 00
- VLAN ID**: [Empty field]
- Base Station Address List**: [Empty list area with Add..., Remove, and Edit... buttons]
- Enable Provisioning**
- SARI/PARK**: 31100243777703
- Subscriptions**: Preconfigured
- Authentication Code**: [Masked with dots]
- Enable Resiliency**
- Status Enquiry Period**: 30
- Prioritize Primary**
- Supervision Timeout**: 120

5. Check that the **Auto-Create Extension** and **Auto-Create User** options are selected.
6. Click **OK**.

- Send the configuration back to the IP Office.

Related links

[Allowing Subscription](#) on page 109

[Allowing Subscription](#) on page 259

Master Base Station

Procedure

- Access the master base stations configuration.
- In the left-hand panel select **DECT**. Select the **System** tab.

- Check that the **Subscriptions** field:

- **With System AC**

IP Office provisioning will automatically set this field when the IP DECT line subscription setting is set to **auto-create**.

- **With User AC**

IP Office provisioning will automatically set this field when the IP DECT line subscription setting is set to **Preconfigured**.

- Note the number set in the **Authentication Code** field.
- Click **OK**.

Related links



[Allowing Subscription](#) on page 109

Manually Creating Extensions

About this task

If the IP DECT line subscription setting is set to **Preconfigured**, you must manually add extension and user entries for each handset to the IP Office configuration.

Procedure

1. Click on  **Extension**.
2. Click on the  icon and select **IP DECT Extension**. This option is greyed out until an IP DECT line is added to the configuration.
3. Select the **Extn** tab. Set the **Base Extension** number to a currently unused extension number.

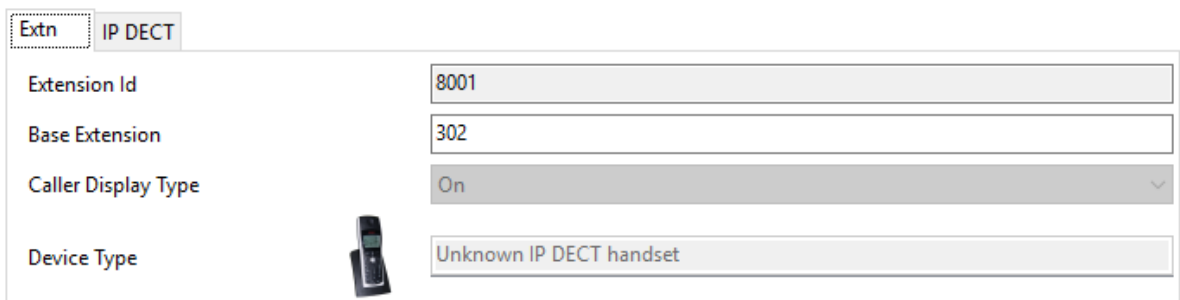

The screenshot shows the configuration form for an IP DECT extension. The 'Extn' tab is active. The fields are: Extension Id (8001), Base Extension (302), Caller Display Type (On), and Device Type (Unknown IP DECT handset). A handset icon is visible next to the Device Type field.

4. Select the **IP DECT** tab.

The appearance of this tab varies depending on whether the IP DECT line has **Enable Provisioning** selected or not. The following example shows this tab when provisioning is enabled.

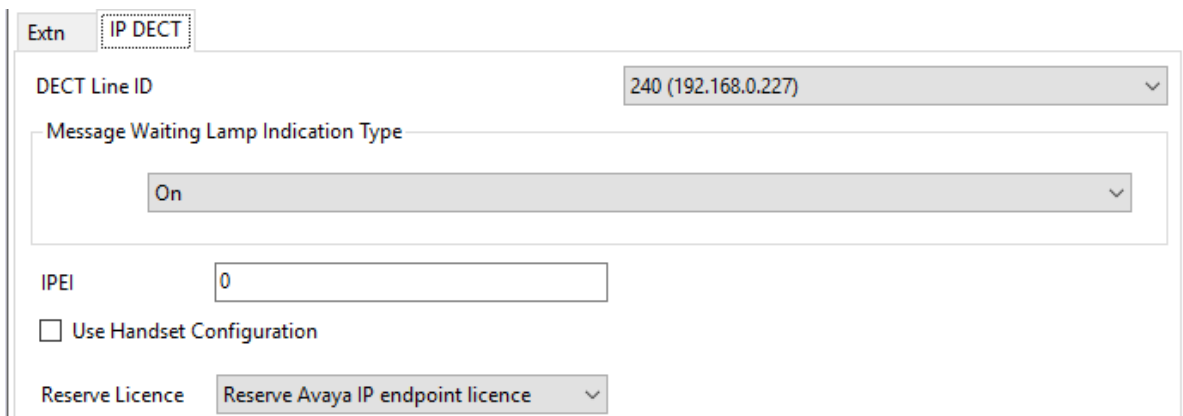

The screenshot shows the configuration form for an IP DECT extension with provisioning enabled. The 'IP DECT' tab is active. The fields are: DECT Line ID (240 (192.168.0.227)), Message Waiting Lamp Indication Type (On), IPEI (0), Use Handset Configuration (unchecked), and Reserve Licence (Reserve Avaya IP endpoint licence).

- a. Set the **Message Waiting Lamp Indication Type** to **On**.
- b. Select the Reserved Avaya IP endpoint license option. This option will be greyed out if there are insufficient licenses. If this option is selected, the phone will be licensed before any other Avaya IP endpoints for which this option has not been set.

- c. Set the IPEI to match that of the handset. For new phones the IPEI is shown on the screen. For other phones it can be displayed by selecting **Menu | Settings | Device Info | IPEI/IPDI**. It is also shown on a label under the battery.
 - For 3700 Series phones, the IPEI can be displayed by selecting **Menu | Settings | Device Info | IPEI/IPDI**. It is also printed on a label under the phone's battery.
 - If **Use Handset Configuration** is selected, the handset user is able to set the phone language and date/time format. If not selected, those settings will be driven by the system or user locale settings in the IP Office configuration.
 - Click **OK**.
 - IP Office Manager will prompt whether you want to create an associated user. Select **Yes**.
 - The user settings are displayed. Adjust any of these if required and click **OK**.
 - Repeat the process to create any other extension and user entries required. Then save the configuration back to the IP Office system.

Related links

[Subscribing Phones](#) on page 108

Subscribing a Phone

The method of subscription is largely the same regardless of whether the IP Office's IP DECT line **Subscriptions** setting is set to **Auto-Create** or **Preconfigured**.

You will need the system SARI code and Authentication Code set in the IP DECT line configuration during the subscription process. You also need to enable subscription, which is only valid for 2 minutes, in the master base station.

Related links

[Subscribing Phones](#) on page 108

[3700 Series Phones](#) on page 113

[Auto-Create Subscription Mode](#) on page 116

[Preconfigured Subscription Mode](#) on page 116

[3701/3711 Phones](#) on page 116

3700 Series Phones

About this task

Using the Telephone user interface, perform the following procedure to subscribe the handsets.

- Switch on the phone:
 - **3720**: Select **Menu | Settings | System | Subscribe**.

- **Others:** Select **Menu | Connections | System | Subscribe.**







Display	Actions
	<p>Details of the phone's current subscription are displayed. Select Next.</p>
	<p>The System name is just used by the phone to identify the different subscriptions it may have. Enter any name and select Next.</p>
	<p>The phone will display a list of telephone system types to which it can connect. Scroll the selected option to IP-DECT and select Next.</p>
	<p>The phone now requires the PARK (SARI) and AC (authentication code) of the system to which it should subscribe. Enter the PARK and then scroll to the AC field. Enter the System AC and select Next.</p>
	<p>The Protection on? prompt is displayed.</p> <ul style="list-style-type: none"> • If you select No, the user can delete the subscription from the list of subscriptions known by the phone. • If you select Yes, the user cannot delete the subscription.

Table continues...

Display	Actions
	<p>A summary of the subscription details is shown. Check that the values are correct</p>
	<p>Select OK. The phone broadcast for DECT systems to which it can subscribe.</p>
	<p>When a DECT system is located, the handset will attempt to subscribe to that system.</p>
	<p>The success or failure of the subscription is indicated.</p>

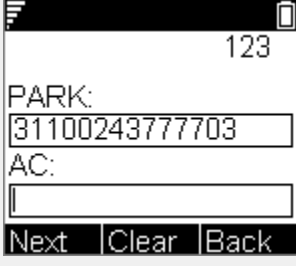
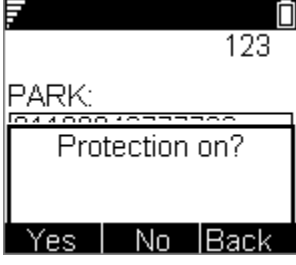
The display shown after successful subscription will depend on whether anonymous subscription is being used or the phone matches an existing extension in the IP Office configuration.

Related links

[Subscribing a Phone](#) on page 113

Auto-Create Subscription Mode

About this task

 <p>The image shows a phone screen with a status bar at the top displaying '01:42' and a battery icon. Below the status bar, the date '12/07/2010' and 'DECT' are shown. The main text on the screen reads 'Enter New Login (620)'. At the bottom, there are two buttons: 'Menu' on the left and 'Back' on the right.</p>	<p>If the phone displays Enter New Login, it has been assigned a temporary extension number, shown in brackets. The temporary number is simply the highest existing extension number plus 1.</p> <ul style="list-style-type: none"> • To accept the temporary extension number as permanent, dial *# and make the call. • To specify a different extension number, dial XXX*LLL# where XXX is the extension number to use and LLL is the Login Code to assign to the user. • To accept the temporary extension as permanent but set a login code for the user, dial *LLL# where LLL is the Login Code to assign to the user.
--	--

Related links

[Subscribing a Phone](#) on page 113

Preconfigured Subscription Mode

About this task

 <p>The image shows a phone screen with a status bar at the top displaying '01:42' and a battery icon. Below the status bar, the date '12/07/2010' and 'DECT' are shown. The main text on the screen reads 'Extn620' followed by '620' on the next line. At the bottom, there are two buttons: 'Menu' on the left and 'Back' on the right.</p>	<p>If the IPEI of the phone matches an existing extension entry in the IP Office configuration, the phone will use the existing settings.</p> <p>This may occur even when using Auto-Create subscription mode if the phone is an existing extension re-subscribing to the system.</p>
--	---

Related links

[Subscribing a Phone](#) on page 113

3701/3711 Phones

About this task

This method is only supported if the IP DECT line's **Subscriptions** setting is set to **Preconfigured** and matching configuration entries for the extensions have been created.

Procedure

1. Switch on the phone.
2. Select **Menu | System | Subscription | Subscribe HS**.
3. Select **PABX-PIN**.
4. Enter the authentication code.

Related links

[Subscribing a Phone](#) on page 113

Upgrading Phones

About this task

It may be necessary to upgrade to software used by the 3700 Series phones. For new installations it is assumed that the Windows Device Manager and advanced chargers will be used for this.

Related links

[Subscribing Phones](#) on page 108

[Installing Windows Device Manager to Upgrade Phones](#) on page 117

[Starting Windows Device Manager](#) on page 120

[Upgrading Phone Software](#) on page 120

Installing Windows Device Manager to Upgrade Phones

Procedure

1. Browse to the location where you unpacked the IP Office software for Avaya Wireless DECT. Locate the `Avaya WinPDM` folder.
2. Double-click on **Setup.exe**.

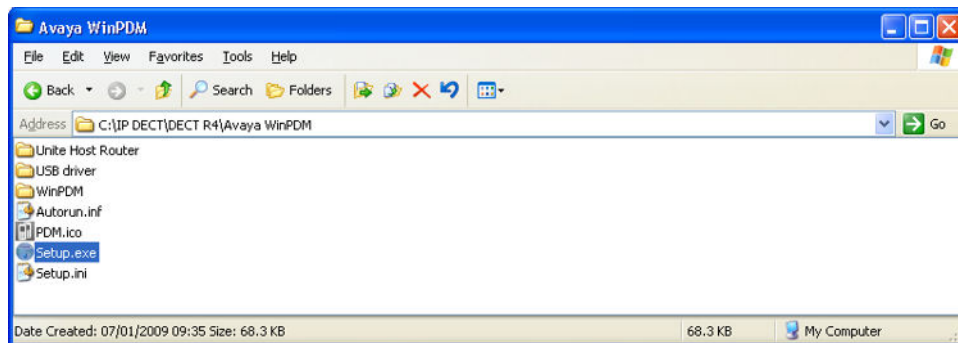

3. Click **Next**.



4. Select **Avaya WinPDM** and click **Next**.

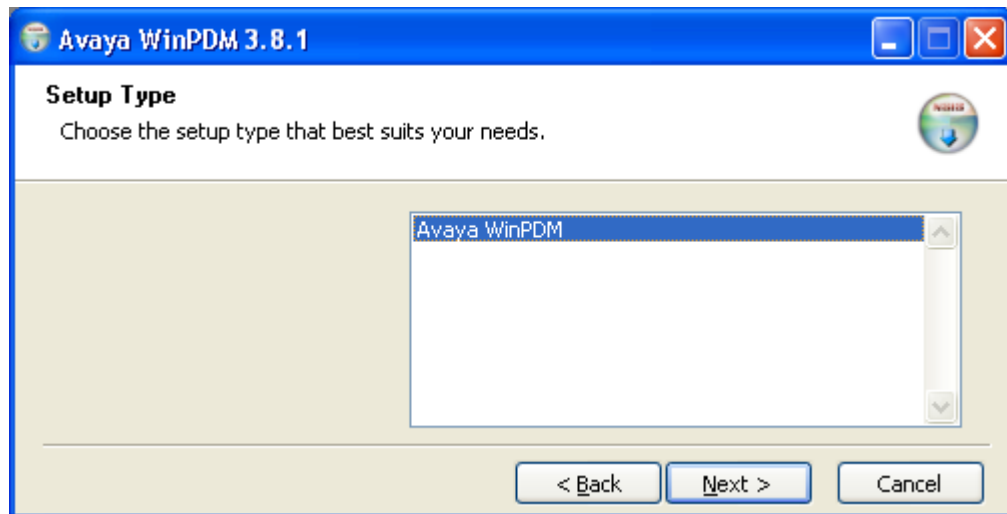

5. Click **Install**.

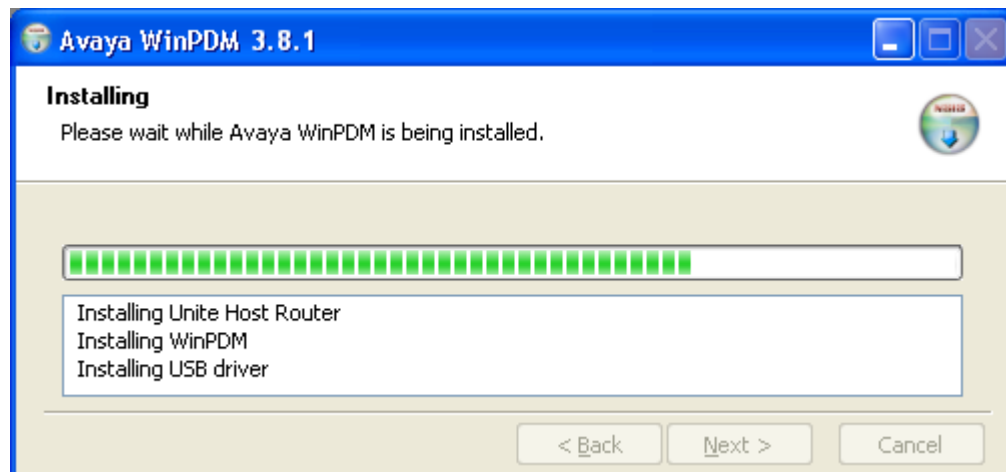
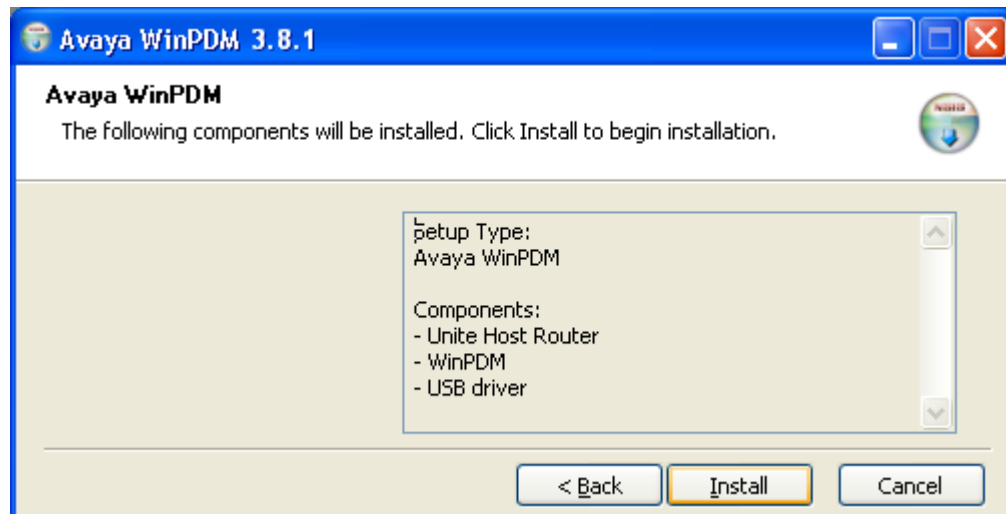

6. When the installation is complete, click on **Finish**.

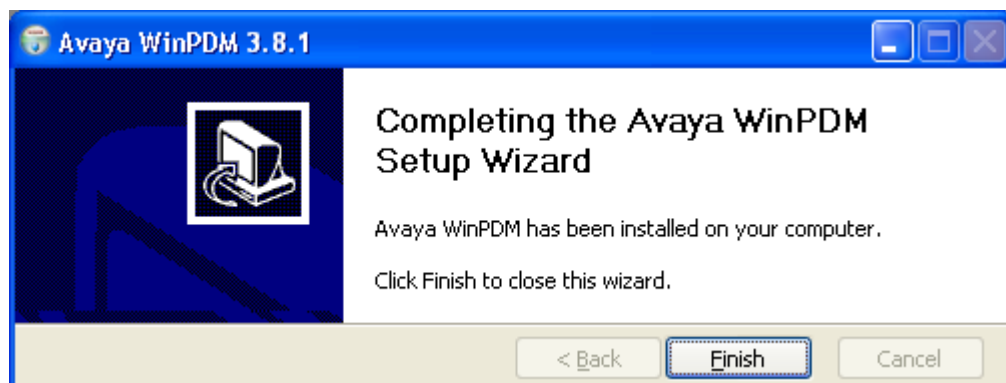

Related links

[Upgrading Phones](#) on page 117

Starting Windows Device Manager

Procedure

1. Select **Start > All Programs > Avaya WinPDM**.
2. Click on the **Avaya WinPDM** icon.
 - If this is the first time you have run Avaya WinPDM:
 - Avaya WinPDM will ask you to create a site. Enter a name for the site and click **OK**.
 - Avaya WinPDM will prompt you to import parameter definition files.

Related links

[Upgrading Phones](#) on page 117

Upgrading Phone Software

About this task

Avaya Wireless DECT is supported on a range of Avaya systems. For IP Office operation, you must use software specifically documented as tested and supported with IP Office. Details of supported software is included in the IP Office Technical Bulletin for each release.

Procedure

1. Within the Avaya Device Manager, select the **Devices** tab.

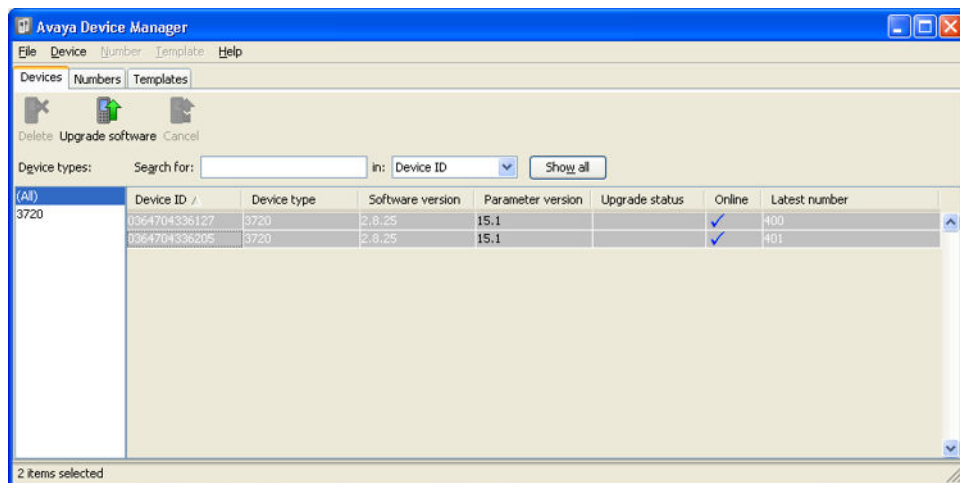

- The current software version of each phone is shown. Compare this to the software versions available, shown by the version set as part of the .pkg file name included with the Avaya Wireless DECT software.

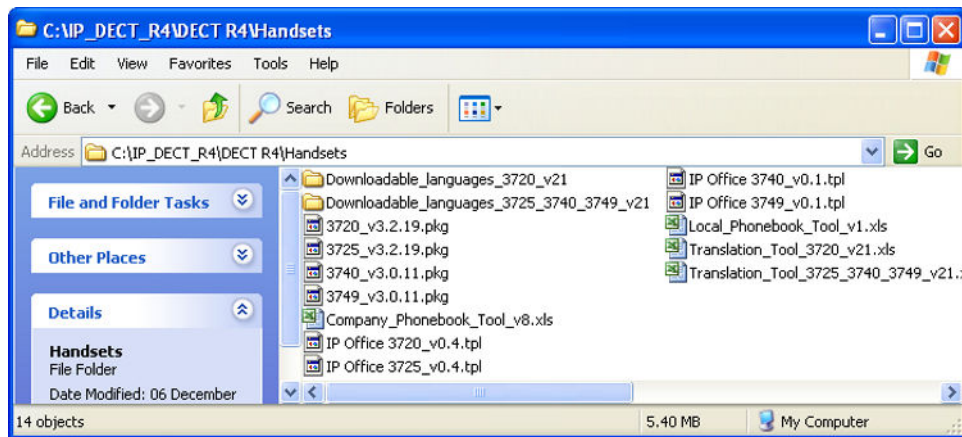

- In the device manager, select the phones that you want to upgrade.
- Click **Upgrade Software**. The menu shown depends on whether you are using the AIWS for an over-the-air upgrade or WinPDM for an in-charger upgrade.

- **AIWS Upgrade Software Menu**

This menu is shown when using the AIWS based device manager to upgrade phones over the air. This method supports a number of additional options but is much slower than upgrading phones in an advanced charger.

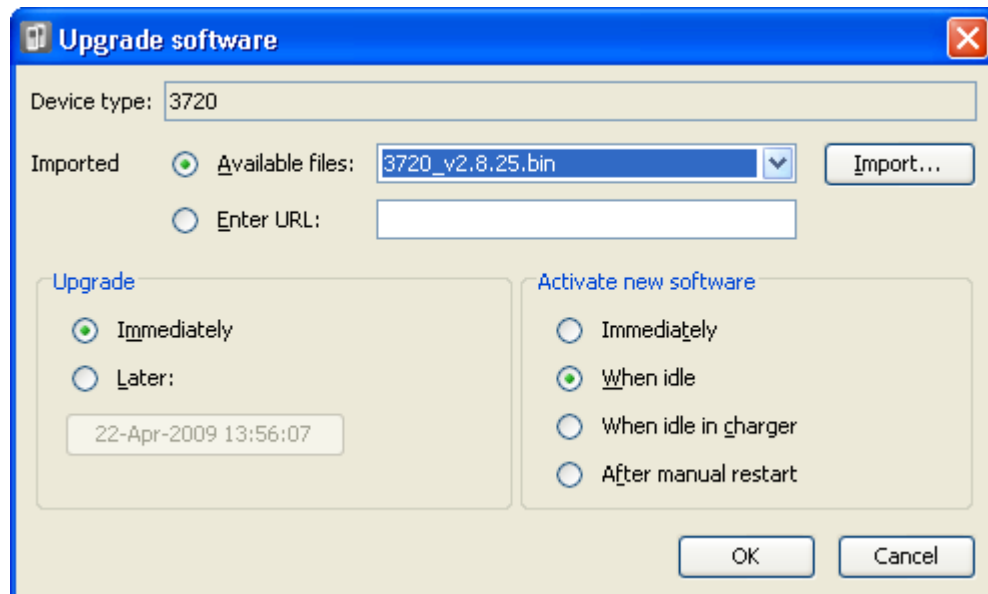

- **Advanced Charger/WinPDM Upgrade Menu**

This menu is shown when using the Windows based device manager to upgrade a phone currently in an advanced charger connected to the PC by USB or LAN. See [Installing Windows Device Manager](#) on page 117.

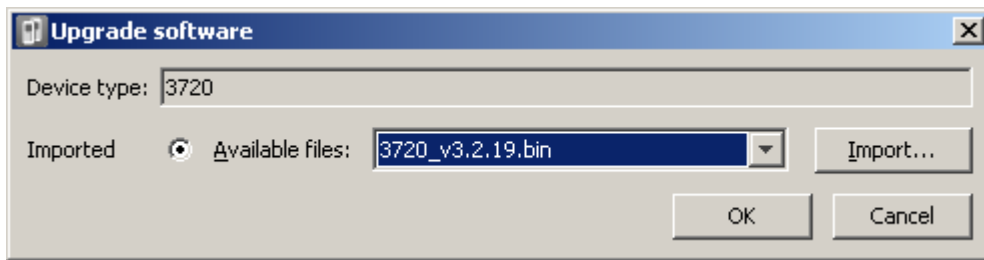

- If you have already imported the parameter definition files for the phones, use the **Available Files** drop-down to select the software bin file for the type of phone being upgraded. Otherwise click on **Import** and browse to the .pkg files for the phone type.
- Select the other upgrade settings required and click **OK**.

The upgrade begins. The following images show a typical upgrade as it is being performed on a 3720 device.

(All)	Device ID /	Device type	Software version	Parameter version	Upgrade status	Online	Latest number
3720	0364704336127	3720	2.8.25	15.1	Downloading	✓	400
	0364704336205	3720	2.8.25	15.1	Downloading	✓	401

(All)	Device ID /	Device type	Software version	Parameter version	Upgrade status	Online	Latest number
3720	0364704336127	3720	2.8.25	15.1	12%	✓	400
	0364704336205	3720	2.8.25	15.1	12%	✓	401

(All)	Device ID /	Device type	Software version	Parameter version	Upgrade status	Online	Latest number
3720	0364704336127	3720	2.8.25	15.1	Complete	✓	400
	0364704336205	3720	2.8.25	15.1	Complete	✓	401

Related links

[Upgrading Phones](#) on page 117

Displaying Subscribed Users

There are a number of ways to display the phones subscribed to the system.

Related links

- [Subscribing Phones](#) on page 108
- [Using the Master Base Station](#) on page 122
- [Using IP Office System Status](#) on page 123

Using the Master Base Station Procedure

1. Login to the master base station.

2. Select Users and select the Users tab.
3. Click on **show**.

Details of the subscribed phones are shown.

Configuration	Users	Anonymous						Logout														
General	PARK 3110024377703		User Administrators																			
LAN	PARK		Long Name Name																			
DECT	3rd pty 2110024755		User Administrators: 0																			
Services	Master Id 0		Users																			
Administration	<input type="text"/> show		<table border="1"> <thead> <tr> <th>No</th> <th>Display</th> <th>IPEI / IPDI</th> <th>AC</th> <th>Prod</th> <th>SW</th> <th>Registration</th> </tr> </thead> <tbody> <tr> <td>660</td> <td>Extrn660 660</td> <td>036470433620</td> <td>1234</td> <td>3720</td> <td>3.2.19</td> <td>Subscribed</td> </tr> </tbody> </table>					No	Display	IPEI / IPDI	AC	Prod	SW	Registration	660	Extrn660 660	036470433620	1234	3720	3.2.19	Subscribed	
No	Display	IPEI / IPDI	AC	Prod	SW	Registration																
660	Extrn660 660	036470433620	1234	3720	3.2.19	Subscribed																
Users			Users: 1																			
Device Overview																						
Backup																						

Related links

[Displaying Subscribed Users](#) on page 122

Using IP Office System Status

The System Status application lists DECT extensions as a subset of H.323 extensions. It can also be used to force the unsubscription of a phone.

AVAYA IP Office System Status

Extension Number	Telephone Type	Active Location	Connection
301	DECT IP	None	Resilient PBX
302	DECT IP	None	Resilient PBX

Related links

[Displaying Subscribed Users](#) on page 122

Unsubscribing Phones

DECT phones can subscribe to multiple DECT systems and can then be switched between the systems to which they are currently subscribed.

The Unsubscribe option provided through phone menus does not unsubscribe a phone from the Avaya Wireless DECT system or IP Office. This option removes details of the subscribed system

from the phone. The Unsubscribe function only works for subscriptions where the Protection option was set to **No** during the original subscription.

Resubscribing the phone reinstates the Avaya Wireless DECT system in the list of systems to which the phone can be subscribed.

To remove a phone from a system that is using IP Office provisioning, the phone's extension entry should be deleted from the IP Office configuration. To remove a phone from a system that is not using IP Office provisioning, the phone's extension entry must be deleted from both the IP Office configuration and the master base station configuration.

Related links

[Subscribing Phones](#) on page 108

Disabling Subscription

About this task

When all DECT phones have been subscribed, Avaya recommends that you disable any further subscriptions. This does not affect re-subscription by extensions that are already configured in the IP Office configuration.

Ensure that no copies of the configuration are open in Manager during subscription, as sending such a copy of the configuration back to the IP Office system will replace the subscriptions and require the handsets to be subscribed again. Following any handset subscription, a new copy of the configuration should always be loaded in IP Office Manager if any other configuration changes are required.

Procedure

1. In IP Office Manager, click on **Line**.
The list of existing lines is shown.
2. Select the **IP DECT Line** previously created.
3. Click on the **Gateway** tab.
4. Change the **Subscriptions** setting to **Disabled**.
5. Click **OK** to save the configuration back to the IP Office system.

Related links

[Subscribing Phones](#) on page 108

Part 4: Avaya Wireless DECT Resilience

Chapter 13: DECT Resilience

From Release 9.1, IP Office Release supports two methods for ensuring continued DECT availability. Both methods can be combined to ensure maximum availability. In both case, it is recommended that normal installation of the system is completed and tested before then adding mirroring and or switch resilience.

- **Master Base Station Mirroring:** It is now possible to configure two base stations to act as 'mirrored' master base stations. One becomes the active master base station whilst the other becomes a standby master base station. If for any reason the active master base station becomes unavailable, the IP Office switches to using the standby master base station to continue DECT operation. Mirroring is not supported between compact and non-compact base stations. However, it is supported between a DECT gateway and non-compact base station.
- **IP Office Switch Resilience:** The IP Office controlling the DECT system can be configured to allow that control to be automatically passed to another IP Office system when it is not available. The SCN line between the two systems can be configured to allow DECT backup for resiliency scenarios in the same was as existing resilience for H.323 IP telephones. If for any reason the primary IP Office system becomes unavailable, DECT control and users are switched to the backup IP Office system.

Related links

[Viewing and Controlling Resilience](#) on page 126

Viewing and Controlling Resilience

Using the IP Office System Status Application you can view the status of both an IP Office system and also any DECT systems to which it is connected. This is done by selecting **System | IP DECT Systems**.

Selecting the IP DECT System then displays details of the particular system and extensions being supported by that system. The addresses and status of the mirrored master base stations is indicated. For the extensions, the connect being used is also indicated.

The menu provides a number of controls:

- **Unsubscribe:** Force the selected extension to unsubscribe.
- **Switch to Backup Node:** Force the DECT connection to switch from the primary IP Office to the fallback IP Office.

- **Switch to Primary Node:** Force the DECT connection to switch from the fallback IP Office to the primary IP Office.

Related links

[DECT Resilience](#) on page 126

Chapter 14: Configuring Base Station Mirroring

To increase resilience of the DECT network, two base stations can be configured to operated as 'mirrored' master base stations. Only one is the active master base station at any time, however the other takes over as the master base station when required.

All the normal requirements for the master base station apply to both the mirrored base stations. That includes the air sync requirements unless air sync is assigned to another base station. See [Configuring Air Sync](#).

Mirroring is not supported between compact and non-compact base stations. However, it is supported between a DECT Gateway and non-compact base station.

Related links

[Configuring the IP Office](#) on page 128

[Configuring the Mirrored Base Stations](#) on page 129

[Activating the Master Base Station](#) on page 129

Configuring the IP Office

In the IP Office system, the IP DECT line needs to be configured with the IP addresses of both of the mirrored base stations.

Procedure

1. Using Manager, retrieve the configuration from the system.
2. Click on **Line**. The list of existing lines is shown.
3. Select the IP DECT line and then select the **VoIP** tab.
4. In the **Gateway IP Address** and the **Standby IP Address** fields, enter the IP addresses of the two base stations that will be mirrored.
5. Save the changes.

Related links

[Configuring Base Station Mirroring](#) on page 128

Configuring the Mirrored Base Stations

Use the following process to the configure the master base station and its mirror.

Before you begin

This process requires access to tabs and fields currently only visible when **Show Advanced Options** is selected.

Procedure

1. Login to the first master base station.
2. Select **DECT** and then select the Master tab.
3. Set the **Mode** to `Mirror`.
4. Set the **Mirror Master IP address** field to the IP address of the other base station.
5. Select the **DECT | Radio** tab.
6. In the **Master IP Address** field, enter the base station's own IP address.
7. In the **Alt. Master IP Address** field, enter the IP address of the other master base station. Click **OK**.
8. Reset the base station.
9. Repeat this process for the other mirrored base station.

Next steps

You can now activate the master base station.

Related links

[Configuring Base Station Mirroring](#) on page 128

Activating the Master Base Station

Only one base station in the mirrored pair acts as the master base station at any time. The initial selection is done through the base station menus of the selected member of the mirrored pair.

Before you begin

This process requires access to tabs and fields currently only visible when **Show Advanced Options** is selected.

Procedure

1. Login to one of the mirrored master base stations.
2. Select **DECT** and then select the **Master** tab.
3. Click **Activate mirror**. That base station is made the currently active master base station in the mirrored pair.

Configuring Base Station Mirroring

Related links

[Configuring Base Station Mirroring](#) on page 128

Chapter 15: Configuring Switch Resilience

For IP Office systems in a multi-site network such as a Small Community Network or Server Edition network, control of the IP Office's DECT system can be transferred to another IP Office system. This failover occurs when the master base station cannot detect its primary IP Office system, that is the IP Office system configured with an IP DECT line to it.

During failover, the specified failover IP Office system takes control and hosts the DECT extensions and users that were previously on the primary IP Office system. However, no changes to the DECT configuration or additional handset subscriptions are allowed.

The failover IP Office system can still host its own Avaya Wireless DECT system using its own IP DECT line and master base station. When that is the case, it can only support failover from another system up to its maximum capacity of DECT users including its existing native DECT users.

For a provisioned installation:

- The centralized phone book is still supported after failover. However, this does not apply if the phone book is being provided by an AIWS.
- An **R** is displayed on the 3700 Series DECT phones when they are in failover.
- By default DECT control and extensions automatically return to the primary IP Office system when it is available again.

For a non-provisioned installation:

- The centralized phonebook is not supported during failover.
- The handsets do not display any indication that their system is in failover.

Related links

[Provisioned Base Station Configuration](#) on page 131

[Non-Provisioned Base Station Configuration](#) on page 132

[IP Office Configuration for Switch Resilience](#) on page 133

[IP Office Line Configuration for DECT Resilience](#) on page 134

Provisioned Base Station Configuration

For a provisioned installation, the master base station needs to be configured to accept a provisioning connection from the backup IP Office system.

Before you begin

This process requires access to tabs and fields currently only visible when **Show Advanced Options** is selected.

Procedure

1. Login to the master base station.
2. Select **Services** and then select the **Provisioning** tab.
3. Set the **Current View** to **Redundant**.
4. Select the **Enable** option.
5. The IP Office security settings control whether HTTPS is supported between the master base station (by default it is supported) and the backup IP Office system.
6. Set the **PBX IP Address** to match the backup IP Office system.
7. In the **User Name** and **Password** fields, set the details that match the fallback IP Office system's service user configured for IP DECT.
8. Ensure that the **Base directory** is set to **/system/backupipdect/** instead of **/system/ipdect/**.
9. Click **OK**.
10. Reset the base station.

Next steps

You must now also configure the IP Office system for switch resilience.

Related links

[Configuring Switch Resilience](#) on page 131

Non-Provisioned Base Station Configuration

For non-provisioned systems, the master base station needs to be configured with details of a redundant trunk connection to the fallback IP Office and when to use that trunk.

Before you begin

This process requires access to tabs and fields currently only visible when **Show Advanced Options** is selected.

Procedure

1. Login to the master base station.
2. Select **DECT** and then select the **Master** tab.
3. Enable the **PBX Resiliency** and click **OK**.

4. Select the **Trunks** tab. Options for configuring the redundant trunk to the backup IP Office system are now displayed.
5. In the **Trunk Settings** section, configure how fallback should operate:
 - **Prioritize primary trunk:** If selected, when during fallback the master base station detects that the primary IP Office has returned to normal operation, it returns DECT control to it. If not selected, the fallback IP Office retains control until it is manually returned using SSA.
 - **Status Inquiry Period:** This field set how frequently (in seconds) the master base station should check the status of the primary IP Office. This value and the Status Enquiry Period set in the IP Office system configuration should match.
 - **Supervision Timeout:** This field sets how long after contact is lost (in seconds) before the master base station should fallback to the fallback IP Office system. This option is only supported a provisioned installation.
6. In the **Redundant Trunks** settings, set the port fields to **1720** and the **CS IP Address** to the IP address of the fallback IP Office system.
7. Click **OK**.
8. Reset the base station.

Next steps

You can now configure the IP Office system for switch resilience.

Related links

[Configuring Switch Resilience](#) on page 131

IP Office Configuration for Switch Resilience

For DECT switch resilience, the IP Office is configured as shown below. Only the primary IP Office needs this configuration. However, for provisioned systems, the security service user on the fallback IP Office must be enabled and configured to match the settings entered for the redundant provisioning connection.

Procedure

1. Receive the IP Office configuration.
2. Click on **Line**. The list of existing lines is displayed.
3. Select the **IP DECT Line**.
4. Select the **Gateway** tab.
5. In the **Enable Resiliency** section, select **Enable Resiliency**.
6. Only change the other values if necessary:

- **Status Enquiry Period:** This field set how frequently (in seconds) the master base station should check the status of the primary IP Office. For a non-provisioned installation, this value should match the Status Inquiry Period set in the master base station.
 - **Prioritize Primary:** If selected, when during fallback the primary IP Office returns to normal operation, DECT control is automatically returned to it. If not selected, the fallback IP Office retains control until it is manually returned using the System Status application.
 - **Supervision Timeout:** This field sets how long after contact is lost (in seconds) before the master base station should fallback to the fallback IP Office system. This option is only accessible here for a provisioned installation. For a non-provisioned installation the value is set through the master base station.
7. Click OK.
 8. Save the settings back to the system.

Related links

[Configuring Switch Resilience](#) on page 131

IP Office Line Configuration for DECT Resilience

The IP Office lines between the systems need to be configured to allow switch resilience.

Procedure

1. Select the IP Office line between the primary system and the backup system.
2. In the **SCN Backup Options**, select **Supports Fallback** and **Backs up my IP Dect Phones**.
3. Save the settings back to the system.

Related links

[Configuring Switch Resilience](#) on page 131

Part 5: Base Station Location Information

Chapter 16: Using IP Office Locations with Avaya Wireless DECT Base Stations

Within the IP Office configuration, you can create locations and associate each extension with a location. The location information can define which ARS is used for emergency calls by the those extensions and address information for sending on SIP trunks. Refer to the [IP Office Emergency Call Configuration](#) documentation.

Whilst a location is assigned to every IP Office extension, there are caveats to the use of locations with Avaya Wireless DECT extensions, see below.

Extension Location without Base Station Location Support

Since by their nature Avaya Wireless DECT extensions can move around a site and between buildings whilst in use, unless the customer site is able to use a single location for all extensions, it is recommended to create a separate location entry for the Avaya Wireless DECT extensions. That entry should warn that the precise physical location of the handset needs to be determined at the time of any emergency call.

Extension Location with Base Station Location Support

For IP Office R11.1 FP2 SP2 and higher, you can assign IP Office locations to each Avaya Wireless DECT base station. When a Avaya Wireless DECT extension makes an emergency call, the emergency settings of the base station's IP Office location are used.

This section of covers the implementation of base station locations.

Related links

[Enabling Base Station Location Support](#) on page 136

[Setting the Base Station Locations](#) on page 137

[Importing Base Station Location IDs from a CSV File](#) on page 137

Enabling Base Station Location Support

In order to use base station location information, the IP Office IP DECT line must be configured to use the location ID's it receives from the DECT base stations.

Procedure

1. Using IP Office Manager or IP Office Web Manager, open the system configuration.
2. Select the IP DECT line.
3. For base station location support, enable the **Call Based Location Information** setting.
4. Save the new configuration.

Related links

[Using IP Office Locations with Avaya Wireless DECT Base Stations](#) on page 136

Setting the Base Station Locations

This process is used to manually assign IP Office location IDs to each of the DECT base stations.

Before you begin

- Obtain a list of the location IDs from the IP Office configuration.

Procedure

1. Login to the master base station.
2. Select **Device Overview** and then select the **Radios** tab.
3. Click on base station name.
4. Enter the IP Office location ID in the **Location ID** field.
5. Enter a description in the **Description** field. This is optional and used as a reminder only.
6. Click **Apply**.

Related links

[Using IP Office Locations with Avaya Wireless DECT Base Stations](#) on page 136

Importing Base Station Location IDs from a CSV File

The location ID's for a set of base stations can be imported from a `.csv` file.

- For IPBS base stations, each entry in the file should have the following format:
 - `<Radio Name>,<Location ID>,<Description>`
 - For example: `IPBS3-25-ec-3d,123456789,Reception`
- For IPBL base stations, each entry in the file should have the following format:
 - `<Radio Name>,<RFP Port>,<Location ID>,<Description>`

- For example: IPBL-30-00-20,16,ABCDF,Conference Room 1

Procedure

1. Login to the master base station.
2. Select **Device Overview** and then select the **Radios** tab.
3. Click on base station name.
4. Click **Import location id's**.
5. Browse to and select the file containing the location ID for each base station.
6. Click **Next>**.
7. Click **OK**.

Related links

[Using IP Office Locations with Avaya Wireless DECT Base Stations](#) on page 136

Part 6: Digital Gateway Installation

Chapter 17: IP DECT Gateway Installation

Before installation ensure that you have performed an assessment of the power consumption requirements of the digital base stations. This will determine whether the base stations can be powered directly by the IP DECT Gateway or each will need their own separate power adapters. If powered using separate power adapters, the EPP power wires from the IP DECT Gateway should not also be connected.

Related links

[IP DECT Gateway Installation Summary](#) on page 140

[Digital Base Station Power Consumption](#) on page 141

[Installing the Digital Base Stations](#) on page 142

[Mounting](#) on page 143

IP DECT Gateway Installation Summary

About this task

The configuration process for the IP DECT Gateway is very similar to that for an IP base station. In a new Avaya Wireless DECT system installation, Avaya recommends that the IP DECT Gateway is installed as the master base station for the system. This does not affect the allowed number of IP and or digital base stations.

The installation of a IP DECT Gateway as a master base station can be done as part of either a provisioned installation or non-provisioned installation. If the IP DECT Gateway is being added to an existing system, it can be added in the same way as for a new slave base station.

A summary of the installation stages is as follows:

Procedure

1. Install in rack.
2. Attach power cable.
3. Connect the unit to the LAN using the LAN1 port.
4. Connect the digital base station cables.
5. Power on the unit.

- Access and configure the unit in the same way as for a base station. The configuration required will depend on whether the IP DECT Gateway is being used as a master base station for the system.

*** Note:**

If an IP DECT Gateway is being installed, Avaya recommends configuring the IP DECT Gateway as the master base station for the system. To configure the IP DECT gateway as a master base station, see [Master Base Station Setup](#) on page 75.

Related links

[IP DECT Gateway Installation](#) on page 140

Digital Base Station Power Consumption

The IP DECT Gateway can be used to power digital base stations via the same cable connection as used for signalling. However, the maximum power provision of the IP DECT Gateway is 15W and the power consumption of each digital base station is dependent on the cable wire size and length. The table below indicates the power consumption and can be used to calculate if the IP DECT Gateway can directly power the digital base stations. In cases where the IP DECT Gateway cannot directly power all the digital base stations, some of the base stations will need a separate power connection.

Cable Length	0.4mm Wire Diameter		0.5mm Wire Diameter		0.6mm Wire Diameter	
	0 EPP	1 EPP	0 EPP	1 EPP	0 EPP	1 EPP
0m	5.0	5.0	5.0	5.0	5.0	5.0
100m	5.2	5.1	5.1	5.1	5.1	5.1
200m	5.3	5.2	5.2	5.1	5.1	5.1
300m	5.6	5.3	5.3	5.2	5.2	5.1
400m	5.8	5.5	5.5	5.3	5.3	5.2
500m	6.1	5.6	5.6	5.4	5.4	5.2
600m	6.5	5.8	5.8	5.5	5.4	5.3
700m	7.1	6.0	6.0	5.6	5.5	5.3
800m	8.1	6.2	6.2	5.7	5.6	5.4
900m	—	6.5	6.5	5.8	5.7	5.4
1000m	—	6.9	6.9	5.9	5.8	5.5
1100m	—	7.3	7.3	6.1	5.9	5.6
1200m	—	8.1	8.1	6.2	6.1	5.6
1300m	—	—	—	6.4	6.2	5.7
1400m	—	—	—	6.6	6.4	5.8
1500m	—	—	—	6.9	6.6	5.8

The following power supply adapters are available to power a base station locally. The maximum length of cable from the adapter to the base station must not exceed 10 meters.

- **For European countries:** Version 130137B.
- **For the United Kingdom:** Version 130136B.
- **For the United States and Canada:** Version 130138A.
- **For Australia:** Version 130139B.

Related links

[IP DECT Gateway Installation](#) on page 140

Installing the Digital Base Stations

Apart from the physical connection and power requirements, no configuration is required. The appropriate firmware files are automatically provided to the base stations by the IP DECT Gateway.

Use the following cable pin-out to prepare the cable for connecting the digital base station to the IP DECT Gateway. Remember to allow sufficient cable length to allow for any potential repositioning of the base stations that may be required.

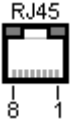
Base Station	Pin	MDI (Crossover)	Wire	Note
	1	Power	White/Orange	Only connection if using the IP DECT Gateway for power. Refer to Digital Base Station Power Consumption on page 141.
	2	Power	Orange/White	
	3	Data 1a	White/Green	—
	4	Data 0a	Blue/White	—
	5	Data 0b	White/Blue	—
	6	Data 1b	Green/White	—
	7	Not used	White/Brown	—
	8	Not used	Brown/White	—

Related links

[IP DECT Gateway Installation](#) on page 140

Mounting

About this task

The base station can now be powered down and mounted in its intended operating position. The removable bracket on the back of the base stations can be used for either wall mounting using two screws suitable for the surface or for mounting on columns using two metal bands.

Related links

[IP DECT Gateway Installation](#) on page 140

[Mounting a Base Station using a Wallmount](#) on page 105

[Mounting a Base Station on a Column/Pillar](#) on page 107

Mounting a Base Station using a Wallmount

About this task

Remove the mounting bracket from the base station. Use it as a template for marking the screw fixing holes. Note the diagram below indicating the required clearance for attaching the base station onto the mounting bracket.

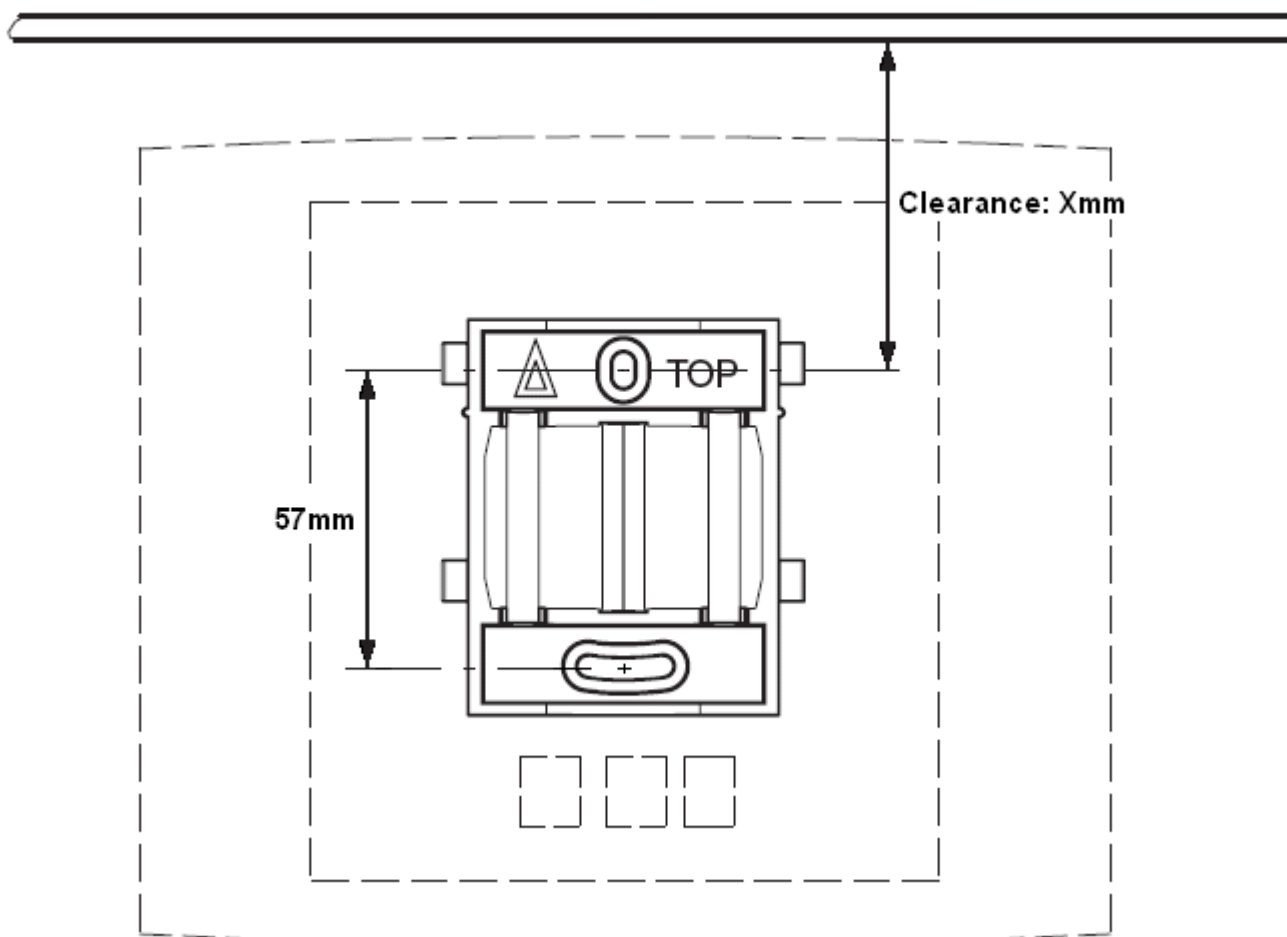

Procedure

1. Hold the mounting bracket with its flat side against the wall with the text 'TOP' upwards and mark the two holes. Observe the minimum distance between the top screw hole and the ceiling. This depends on the base station type as follows:

Base Station Type	Internal Aerials	External Aerials
IPBS1 Digital Base Station	65mm	160mm
IPBS2/IPBS3	100mm	195mm

2. Drill the two holes using a 6mm diameter drill and insert the included wall plugs.
3. Position the mounting bracket with its flat side to the wall and fasten it with the two included 3.5mm diameter screws.

Related links

[Base Station Mounting](#) on page 105

[Mounting](#) on page 143

[Mounting a Base Station](#) on page 255

Mounting a Base Station on a Column/Pillar

The mounting bracket can be fixed to a pole of 45mm diameter or greater, or a beam of 50mm width minimum by using a strap or flexible metal band less than 30 mm wide. A suitable strap or flexible metal band is not included with the base station.

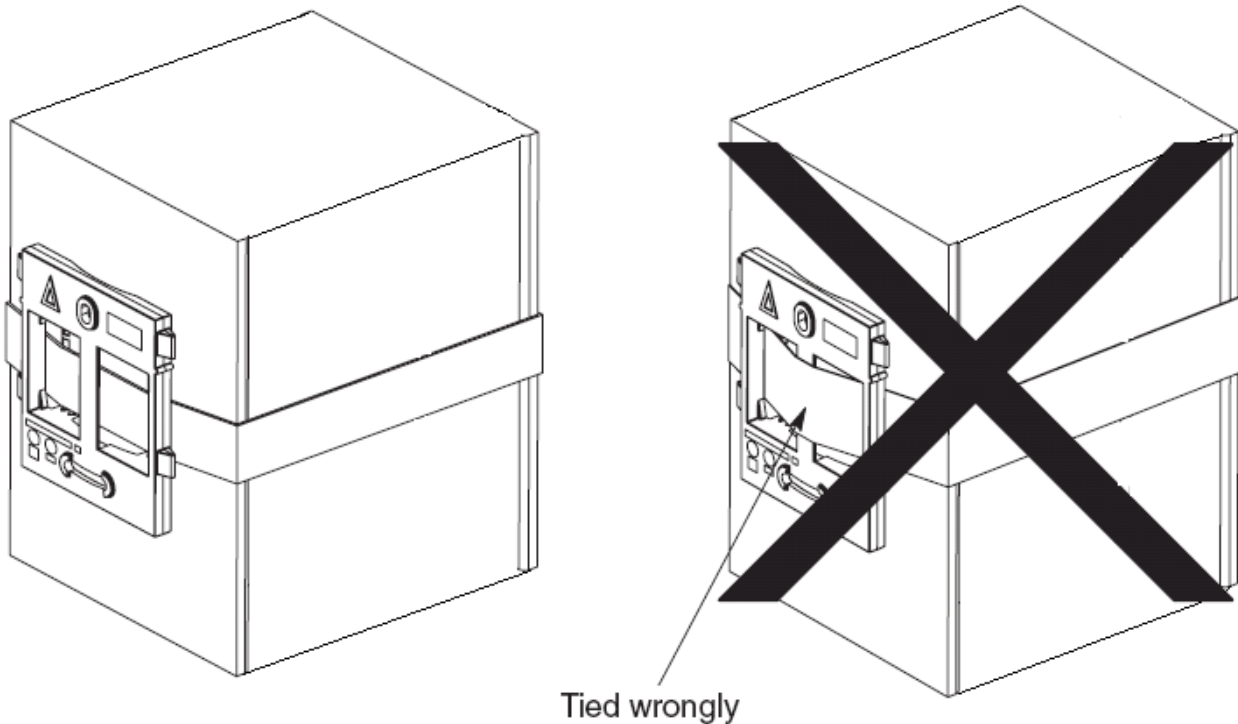

Note: Mounting a wireless base station directly on a steel beam or pillar could result in signal disruptions, such as dead zones or reflections. If it is absolutely necessary to mount the base station on a metallic surface, use spacers to separate the base station from the surface by 20-25 cm.

Related links

[Base Station Mounting](#) on page 105

[Mounting](#) on page 143

[Mounting a Base Station](#) on page 255

Part 7: IP Office User Phone Features

Chapter 18: IP Office User Features

The 3700 Series phones can support a number of IP Office specific features as detailed in this section of the manual.

- For Avaya Wireless DECT systems installed using IP Office provisioning, the IP Office system automatically provides the 3700 Series phone users with the additional IP Office specific features.
- For Avaya Wireless DECT systems not installed using IP Office provisioning, you can apply feature settings using the DECT phone templates, see [Device Management](#) on page 155. The default templates provided with the IP Office administration software include the settings for the additional IP Office features.

Related links

[Idle Display](#) on page 147

[Status Indicators](#) on page 148

[Call Services](#) on page 149

[In Call Options](#) on page 151

[Call Waiting Options](#) on page 152

Idle Display

The phone idle display shows a number of information elements. They are, from top down:

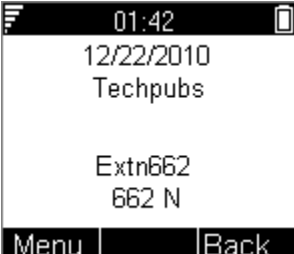
	<ul style="list-style-type: none">• The signal strength, time and battery charge. The battery charge will flash when below 5%.• The date from the IP Office system.• The name of the current subscription.• The IP Office user name.• The IP Office extension number and status indicators (see below).• The soft key labels. The options here relate to the 3 buttons below the screen and change according to the current phone state.
---	---

Related links

[IP Office User Features](#) on page 147

Status Indicators

The IP Office status indicators are shown after your extension number on the display. There may be more than one indicator shown. The possible status indicators are:

Indicator	Description
B	Barred A B is shown on your phone's display when the system administrator has set you to outgoing call barred status. You will only be able to make internal calls while this is applied.
D	Diverting (Forwarding) Calls A D is shown after your extension name on the phone's idle display when you have forward unconditional enabled.
G	Group Member (In Group) A G is shown after your extension name on the phone's idle display when have been configured as a member of a hunt group and your membership is enabled. While this is the case, you may receive calls targeted to the hunt group.
H	Held Call An H is shown after your extension name to indicate that you have a held call or calls on the IP Office system.
N	No Calls (Do Not Disturb) An N is shown after your extension name when you have do not disturb enabled.
O	Out of Service An O is shown on your phone's display when any of the groups of which you are enabled as a member is set to night service mode. In that mode calls to that group are diverted to its fallback if set or otherwise to voicemail if available.
P	Parked Call A P is shown after your extension name to indicate that you have a park call or calls.
T	Twinned A T is shown after your extension name on the phone's idle display if it is internally twinned with your deskphone. Calls to you will alert on both phones and can be answered by you at either phone.
R	Resilience An R is shown after your extension name on the phone's idle display your phone is working in resilience mode. This is used when there may have been a problem with the telephone system to which your phone was registered and another IP Office system is currently providing support for your phone. In this mode, some features may not be available and calls may be routed differently.
S	System Alarm If you are configured as a system administrator, an S in the phone's display indicates a system alarm. This is for information only, you are not expected to fix the alarm, just report it.

Related links

[IP Office User Features](#) on page 147

Call Services

The following options can be accessed when the phone is idle or the current call is parked or held.

1. Press **Menu**. Scroll the display to **☰ Calls** and press **Select**.
2. Scroll down to **Call services** and press **Select**.
3. The list of available services is displayed. Scroll to the required service and press **Select**.
4. For some functions you may need to enter additional data on the display or select from a list. Do this and press **OK**.
5. The phone sends the appropriate signals to the IP Office.
6. Hang up the call.

The available services are:

Service	Description
Call Pickup Any	Answer the first available call ringing anywhere on the phone system (unless the call is on a private line). Details of the callers and the original call destination will be displayed.
Call Pickup	You can use this option to answer a call ringing at another extension. Select the option and enter the extension number.
Call UnPark	Retrieve a call from the parked state. To do this you need to enter the park slot number assigned to the call when it was parked. You can park a call using the Park Call option and assign it an park slot number at the same time that you or another user can then use to unpark the call.
Call Waiting Suspend	You can use this option to temporarily switch off call waiting. It will remain off until the end of your next call. Use this when you do not want a call interrupted by call waiting tones.
Cancel Call Fwd	You can use this option to switch off all your call forwarding. It does not affect the forwarding numbers, just your use of forwarding. If you have redirected your calls to another phone using follow me on that phone, this option also cancels the follow me feature.
Do Not Disturb On	<p>You can use this option to switch do not disturb on. Calls to you go to your voice mail mailbox if available, otherwise they receive busy. They do not follow any forwarding settings. A N for no calls is shown on the phone's idle screen when you have do not disturb switched on.</p> <ul style="list-style-type: none"> • Some numbers can be configured as do not disturb exceptions. You can do this using the one-X Portal for IP Office application or from the menu of some desk phones (contact your system administrator for details). Those numbers are able to call you and transfer calls to you while you have do not disturb switched on.

Table continues...

Service	Description
Do Not Disturb Off	You can use this option to switch do not disturb off. When off, calls will alert the handset and or follow your forwarding settings.
Fwd Unconditional On	You can use this option to switch immediate call forwarding on. A forwarding number needs to be set for this to work, use the Fwd number call service to see and edit your current forwarding number. By default internal and external calls to you are forwarded but hunt group calls are not. However the settings for internal and hunt group calls can be adjusted by your system administrator. To switch off forwarding, use Cancel All Fwd .
Fwd Busy On	You can use this option to switch on forwarding of any additional calls when you are already have a call connected. If you have call waiting enabled, it is used for additional calls when you already have a call connected and another one waiting. To switch off forwarding, use Cancel All Fwd .
Fwd No Answer On	You can use this option to forward any call that rings the handset without being answered. To switch off forwarding, use Cancel All Fwd . <ul style="list-style-type: none"> • The default no answer time used to trigger the forward is 15 seconds. However this time can be adjusted by your system administrator if required. • If you use voicemail, the forward is used first. However if the call is still unanswered, the phone system will still attempt to redirect the call to voice mail. This may not be possible for calls forwarded to external numbers.
Fwd Number	You can use this option to see and set the number to which your calls are forwarded when you select Fwd Unconditional On . If your system uses an external dialing prefix, remember to include it if you want to forward calls to an external number. However, note that external forwarding may be restricted by your system administrator. This number is also used for Fwd Busy On and Fwd No Answer On unless you set a separate Fwd Busy Number .
Fwd Busy Number	You can use this option to see and set the number to which your calls are forwarded when you select Fwd Busy On and or Fwd No Answer On . If your system uses an external dialing prefix, remember to include it if you want to forward calls to an external number. However, note that external forwarding may be restricted by your system administrator. To switch off forwarding, use Cancel All Fwd .
Follow Me Here On	If you are a temporary user of the phone, you can use this option to have calls to your desk phone redirected to the handset. Select this option and enter your extension number.
Follow Me Here Off	To end a follow me set using Follow Me Here On , select this option and enter your extension number. Calls to that number will no longer be redirected to the handset.

Table continues...

Service	Description
Login	<p>Users with a login code can 'hot desk', that is login at any phone on the system and, when finished making or taking calls, log out. While logged in on a phone, that phone adopts all their user settings and their calls are routed to it. This option can be used in a number of ways.</p> <ul style="list-style-type: none"> • The DECT handsets can be configured with no permanently associated user. To use the phone, you need to login using your extension number and login code. • The DECT handsets can be configured with an associated user. However, you can use log in and log out as a method of security for your phone. • Other users can use their log in code when they temporarily need to use your handset as their own phone. While they do this you are logged out. • Note that SMS messaging, provided by the AIWS, always goes to the same original handset even when the associate user hot desks to another handset.
Logout	<p>If you have a login code, you can log out of the phone you are currently using. When you log out, if you are normally associated with another phone, you are automatically logged back in on that phone unless someone else is using it or you are set to forced login. If you are not automatically logged in elsewhere, then while logged out your are treated as being busy to all calls. Instead your calls go to voice mail if available.</p>

Related links

[IP Office User Features](#) on page 147

In Call Options

During a call, the **More** soft key can be used to access a number of handset and IP Office functions while still remaining connected to the call.

1. During the call, press **More**.
 - If the phone is not currently on the call details screen, you may have to press **Back** to get to that screen before you can press **More**.
2. Select the function required.
3. Some functions may require you to enter some data, for example the destination for a transfer.

The possible functions are:

Option	Description
Auto Callback	<p>If you are making a call to another extension and it has not been answered, setting a callback tells the phone system to ring you when that extension finishes its next call. When you answer the target extension is rung again.</p>

Table continues...

Option	Description
Call Park	<p>You can use this option to park your current call. You can enter a park slot number which is then useable by anyone else on the system to unpark the call.</p> <ul style="list-style-type: none"> • If you do not enter a park slot number when parking a call, one is automatically assigned using your extension number plus a digit 0 to 9. • When you park a call, a P is shown on your phone's idle display until the call is unparked or the caller hangs up. • Parked calls automatically re-ring you if left parked for too long (the default time is 5 minutes).
Clear Call	<p>Use this option to end the current call and answer a held call. This may be useful when trying to transfer a held call and you find yourself connected to the transfer destinations voicemail or busy tone. Similarly you can use it when trying to add another party to a conference if the other party does not answer or does not want to be part of the conference.</p>
Clear Call Waiting	<p>You can use this option to end your current call and automatically answer the waiting call.</p>
Conference Add	<p>You can use this option to start a conference with the current call and any calls you currently have on hold. The conference is automatically assigned a conference number that is shown on the display.</p> <p>To add another party to the conference, press R to put your connection to it on hold and dial the other party. When answered select More > Conference Add.</p> <p>Note: This menu option is <i>only</i> available on DECT phones that were configured during a provisioned installation. If you performed a non-provisioned installation, you will require a short code (*47) menu item to invoke the Conference Add feature.</p>
Hold Call Waiting	<p>You can use this option to put your current call on hold and automatically answer the waiting call.</p>
Call Record	<p>You can use this option to switch on call recording if your phone system includes IP Office VoiceMail Pro.</p>
Microphone Off	<p>You can use this option to turn the handset's microphone off. A  icon is displayed on the call details screen. The microphone is automatically re-enabled when you next make or answer a call.</p>
Microphone On	<p>You can use this option to turn the handset's microphone back on if you have turned it off during the call.</p>

Related links

[IP Office User Features](#) on page 147

Call Waiting Options

By default call waiting is turned on for all users. On the DECT display with a call already connected, another incoming call will cause you to hear a single beep and the phone display will alternate between details of your current call and the waiting call.

You can only have one connected call plus one waiting call. Any further calls will see you as being busy and will either follow your forward on busy settings if set or else go to voicemail if available. If you don't answer the waiting call, it will follow your forward on no answer settings if set or else go to voicemail.

If you end your current call while you have a call waiting, the waiting call will start ringing and can be answered. You can end your current call and automatically answer the waiting call by using the Clear Call Waiting option. You can hold your current call and automatically answer the waiting call by using the Hold Call Waiting option.

Related links

[IP Office User Features](#) on page 147

Part 8: Device Management

Chapter 19: Device Management

This section covers the use of the device management to:

- Update the firmware on the phones.
- Apply customized features templates to the phones.
 - The use of the Device Management Application to load templates is not supported for systems installed and maintained using IP Office provisioning mode. In that mode, the IP Office automatically applies settings that match those detailed in [IP Office User Features](#) on page 147.

There are two variants of the device management application that you can use:

- **AIWS Device Manager**

This version of device manager is embedded on the AIWS unit and accessed using a browser. You can use the AIWS device manager to load files to DECT handsets over the air.

- **WinPDM (Windows Portable Device Manager)**

This version of the device manager application is installable as a Windows PC application. You can use this application to load files onto a DECT handset whilst the handset is in an advanced charger (a charger with a USB and/or LAN port).

Related links

[Starting AIWS Device Manager](#) on page 155

[Loading Parameter Definition Files](#) on page 156

[Loading Phone Templates into Device Manager](#) on page 158

[Applying Templates to Phones](#) on page 160

[Editing Templates](#) on page 162

Starting AIWS Device Manager

Procedure

1. Enter the IP address of the AIWS into the browser address field.

Alternatively enter `http://Elise-0091921` as the address, replacing the digits with the AIWS unit's Module Key. The Module Key is printed on the AIWS circuit board

2. If a security certificate warning appears, select it to continue.

3. Enter a user name and password. The default values are **admin** and **changeme**.

The AIWS menu is shown:



Related links

[Device Management](#) on page 155

Loading Parameter Definition Files

About this task

The parameter definition files supplied with the Avaya Wireless DECT software include software files used to update the phone software. These files must be uploaded to WinPDM in order to allow phones to be upgraded.

Procedure

1. Start the AIWS Device Manager or Windows Device Manager.
2. Select **File | File management**.

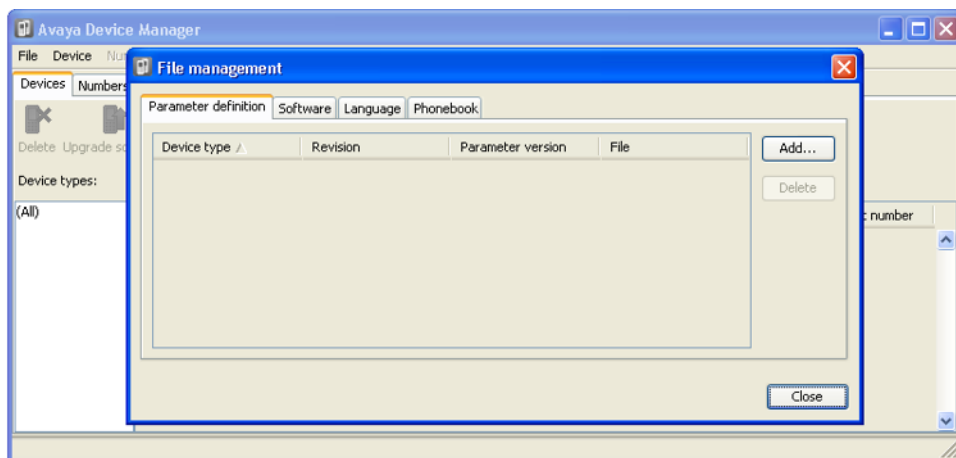

3. Select the **Parameter definition** tab. Click **Add**.

4. Browse to the `Handsets` folder in the software previously unpacked. Select the `.pkg` files in the folder and click **Open**.

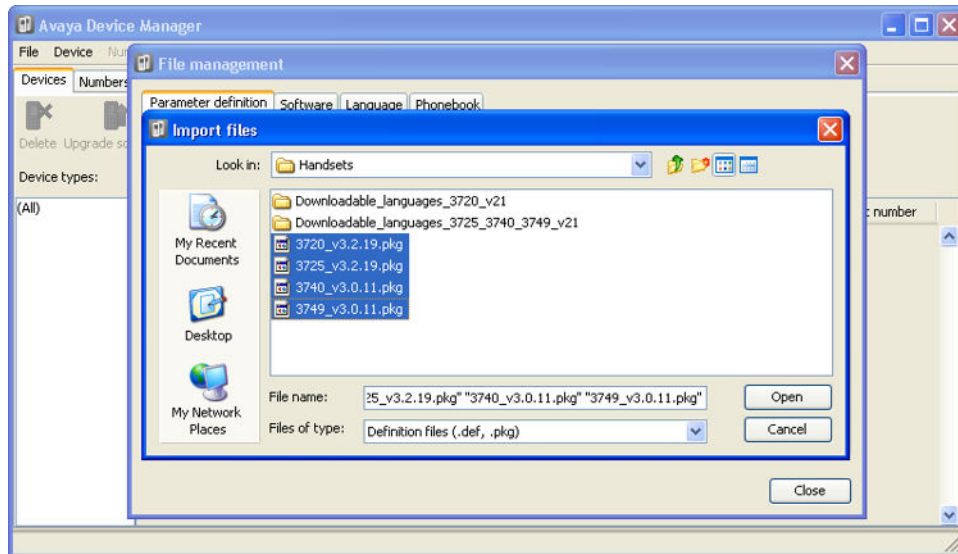

5. Click **Add...**.
6. Browse to the `Chargers` folder in the software previously unpacked. Select the `.pkg` files in the folder and click **Open**.

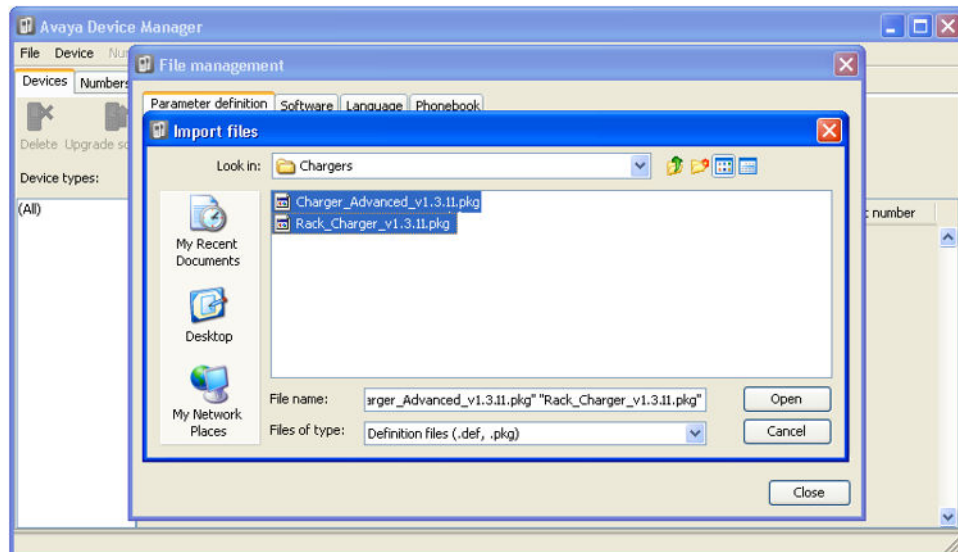

7. The list of parameter definition files should now be complete.

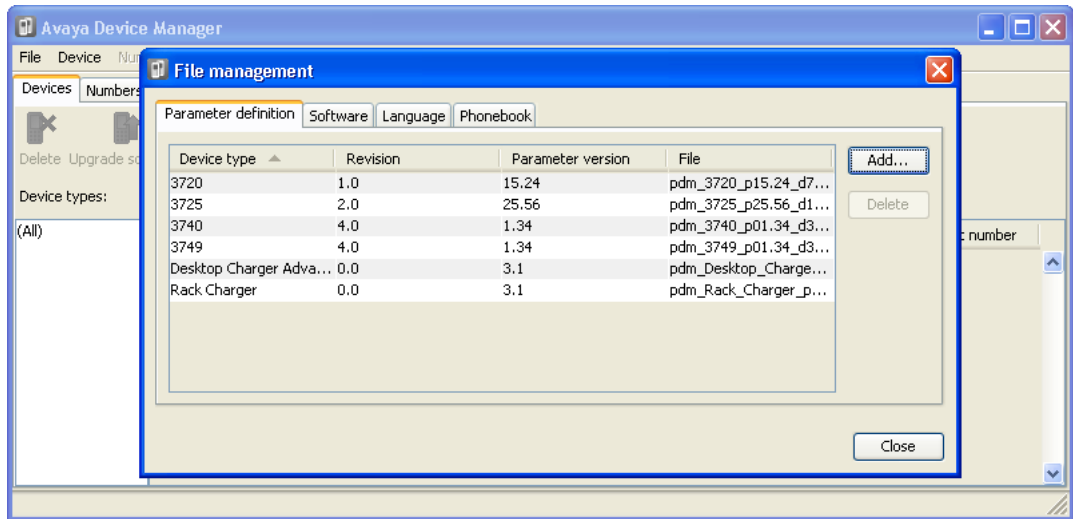

8. Select **Close**.

Related links

[Device Management](#) on page 155

Loading Phone Templates into Device Manager

About this task

Templates allow you to apply common settings to phones and chargers. The IP Office Avaya Wireless DECT software set includes default templates for 3700 Series phones that allow those phones to access IP Office functions (see [IP Office User Features](#) on page 147) through the phone menus.

- The use of the Device Management Application to load templates is not supported for systems installed and maintained using IP Office provisioning mode. In that mode, the IP Office automatically applies settings that match those detailed in [IP Office User Features](#) on page 147.

Procedure

1. Select the **Devices** tab. The phones subscribed to the DECT system should be listed.

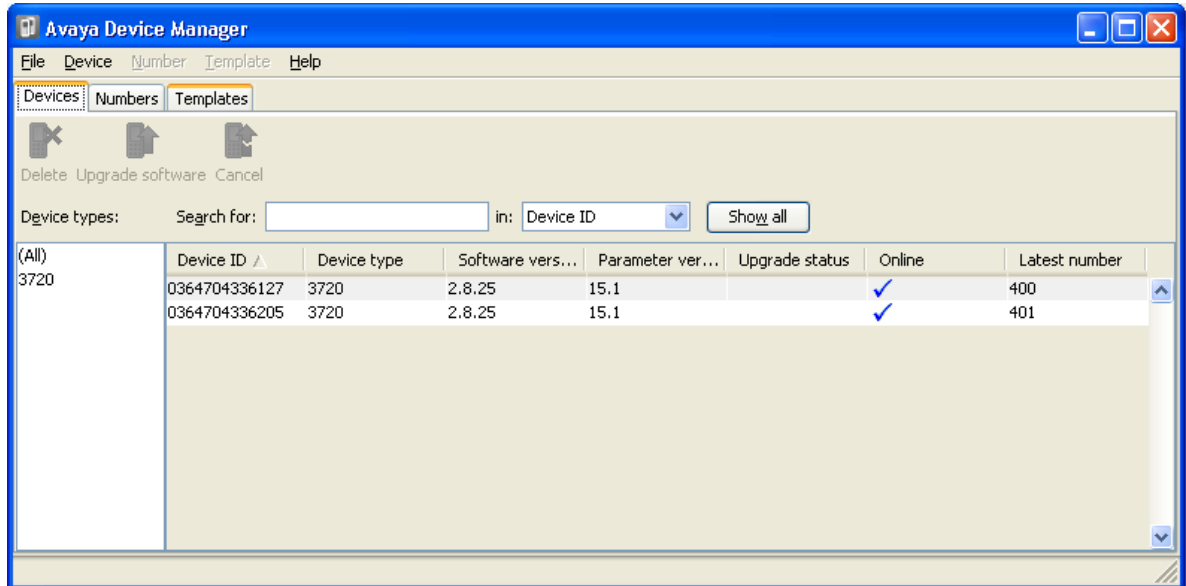

2. Select **File | Import | Templates...**

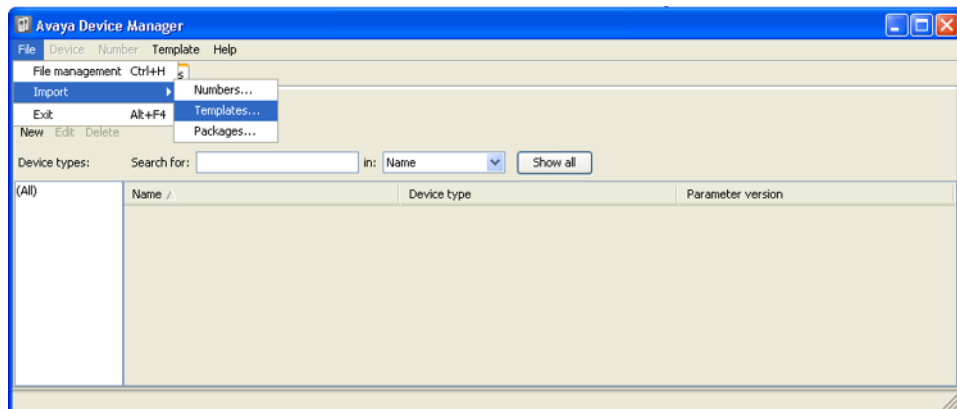

3. Browse to the previously unpacked software and select the **.tpl** template files.

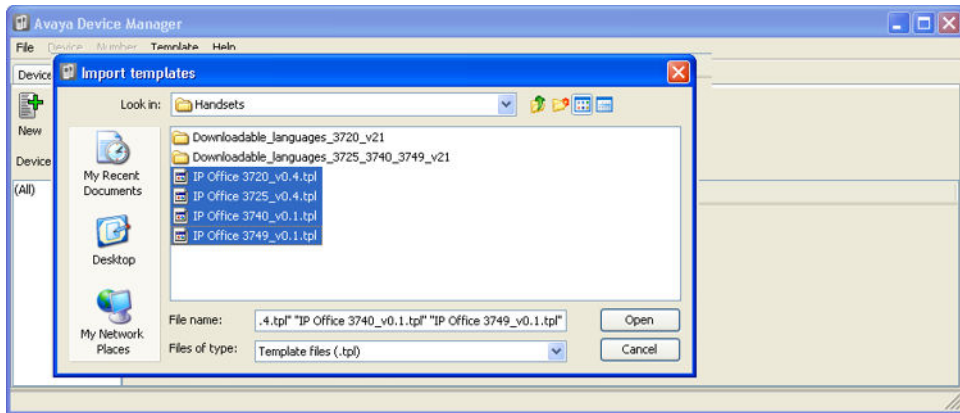

4. Click **Open**. The template files are loaded into Avaya Device Manager.

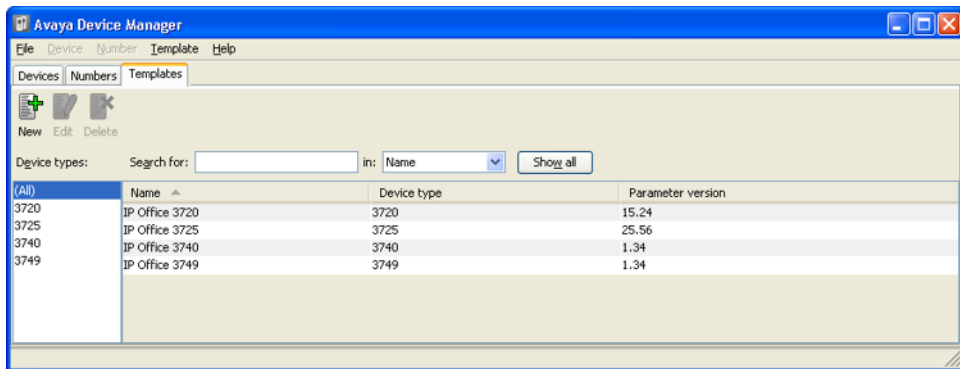

Related links

[Device Management](#) on page 155

Applying Templates to Phones

About this task

The use of the Device Management Application to load templates is not supported for systems installed and maintained using IP Office provisioning mode. In that mode, the IP Office automatically applies settings that match those detailed in [IP Office User Features](#) on page 147.

Procedure

1. Within the Avaya Device Manager, select the **Templates** tab.

2. Right-click on the template and select **Apply to....**

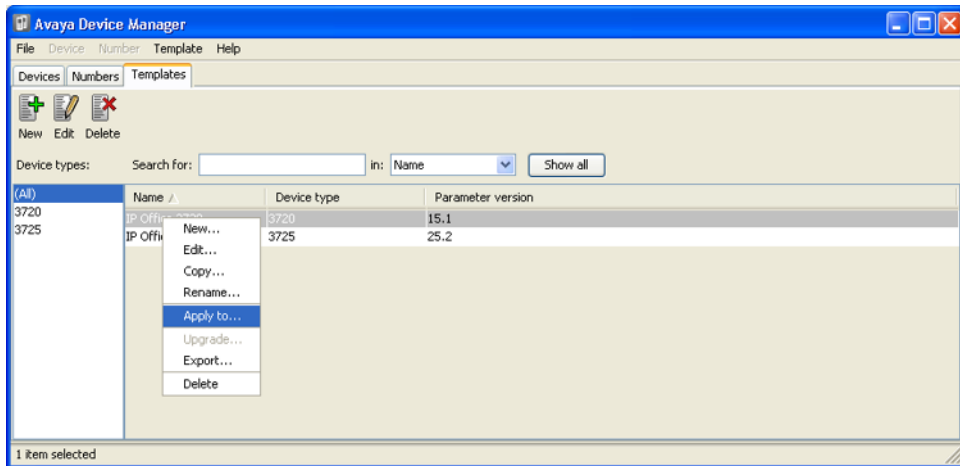

3. Select the phones to which you want the template to be applied. Click **OK**. The phones will begin uploading the template file.

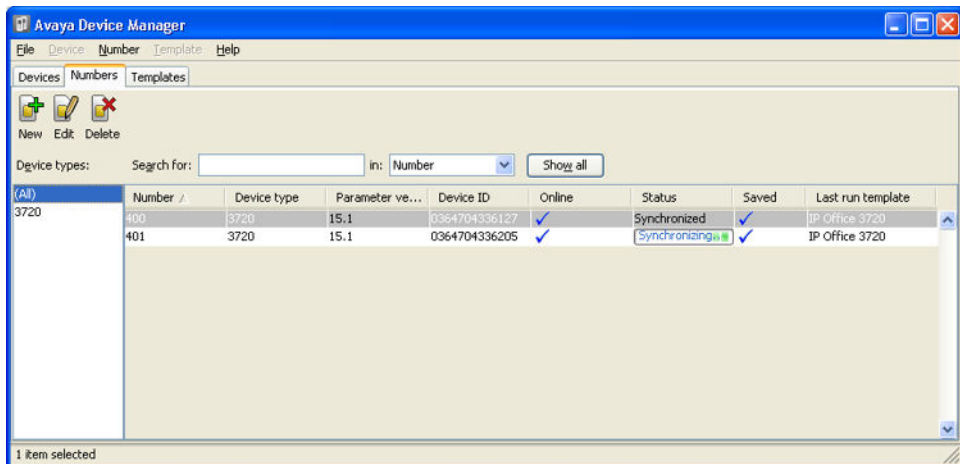
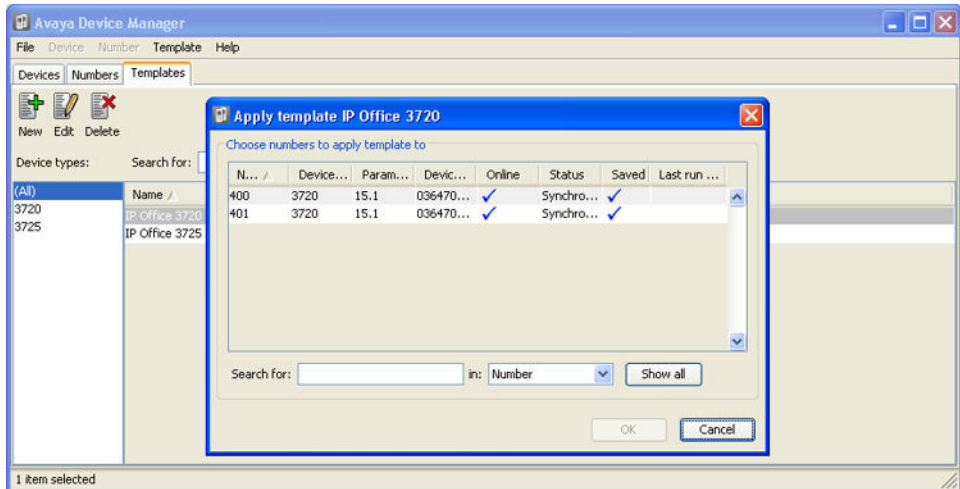

Related links

[Device Management](#) on page 155

Editing Templates

Procedure

1. Within the Avaya Device Manager, select the **Templates** tab.
2. Right-click on the template and select **Edit**. Alternatively to create a new template, right-click on the template and select **Copy** and enter a new name for the new template.

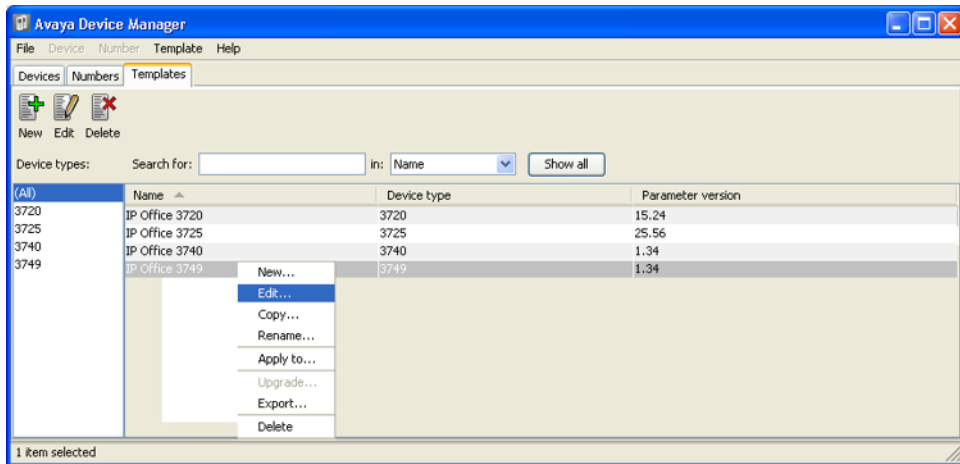

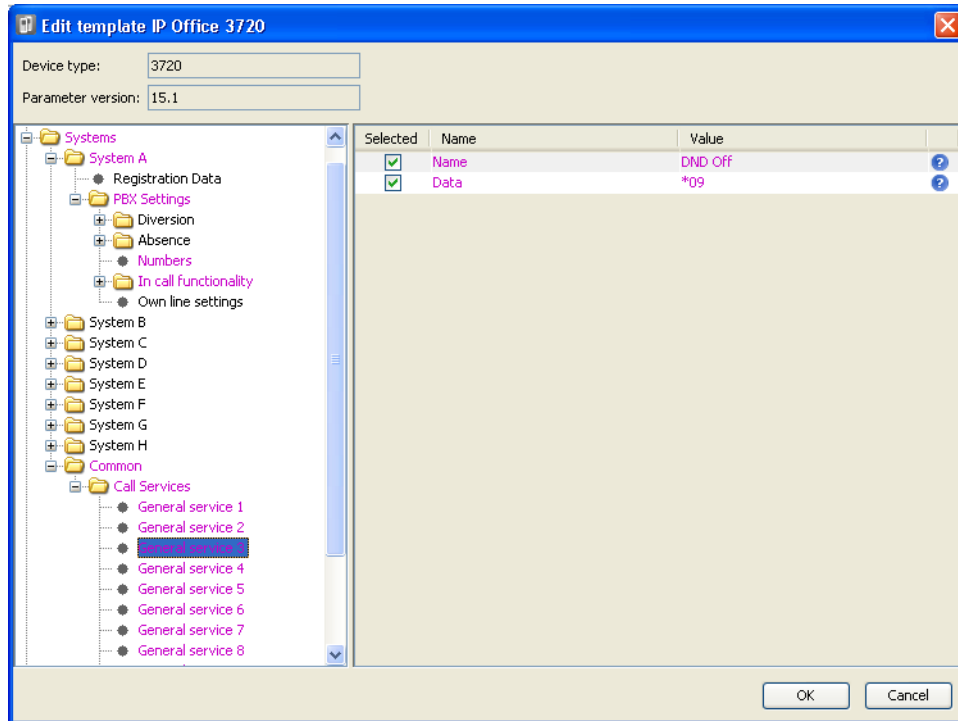

- **Systems | System A | PBX Settings | In call functionality**

Defines the options shown on the **More** menu shown on 3700 Series phones when on a call. This can be used to enter the IP Office short codes for functions such as call park, conference and transfer.

- **Systems | Common | Call Services**

Defines the options shown on the 3700 Series phone Call Services menu. This can be used to enter the IP Office short codes for functions such as call pickup, DND on/off.

- The items shown in pink indicate areas of the template that contains settings selected to be applied to the device when the template is uploaded to the device. Items shown in blue have been changed during this editing session.
- **Black:** Normal
- **Dark Blue:** Parameter has been edited during the current session.
- **Purple:** The parameter is enabled in the template.
- **Red:** Value not valid.
- **Turquoise:** The value differs from the default value
- Each item within the template consists of three parts:
 - **Selected** - If selected, the template value will be applied to devices to which the template is uploaded.
 - **Name** - The non-editable name for the template item.

- **Value** - The value for the template item. This may be a drop-down list from which selection can be made.

- Click **OK**.

Related links

[Device Management](#) on page 155

Chapter 20: Upgrading Phone Software

About this task

Avaya Wireless DECT is supported on a range of Avaya systems. For IP Office operation, you must use software specifically documented as tested and supported with IP Office. Details of supported software is included in the IP Office Technical Bulletin for each release.

Related links

[Installing Windows Device Manager to Upgrade Phones](#) on page 165

[Starting Windows Device Manager](#) on page 168

[Upgrading Phone Software](#) on page 168

Installing Windows Device Manager to Upgrade Phones

About this task

As an alternative to the Device Manager application integrated into the AIWS unit, a copy of Windows Device Manager can be installed onto a Windows PC.

Procedure

1. Browse to the location where you unpacked the IP Office software for Avaya Wireless DECT. Locate the `Avaya WinPDM` folder.
2. Double-click on **Setup.exe**.

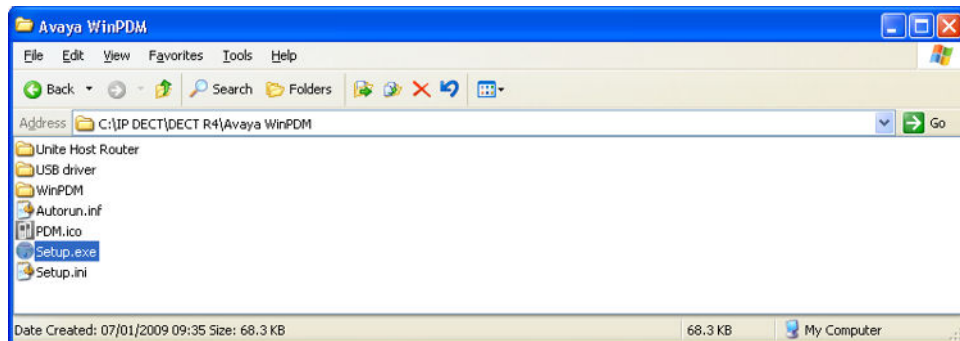

3. Click **Next**.



4. Select **Avaya WinPDM** and click **Next**.

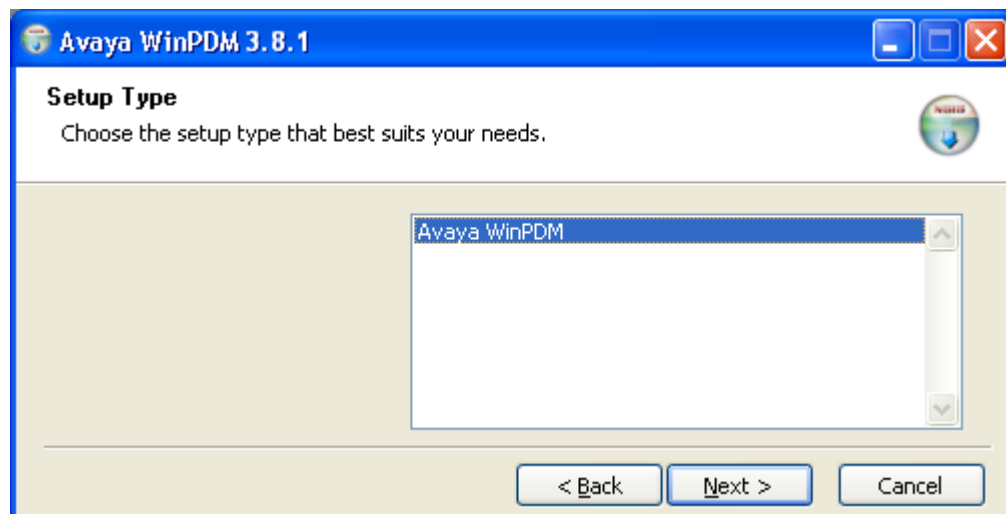

5. Click **Install**.

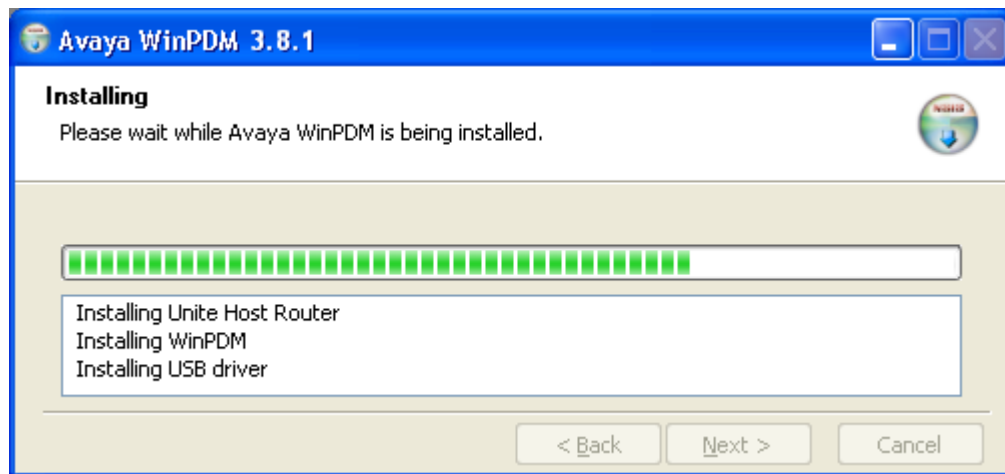
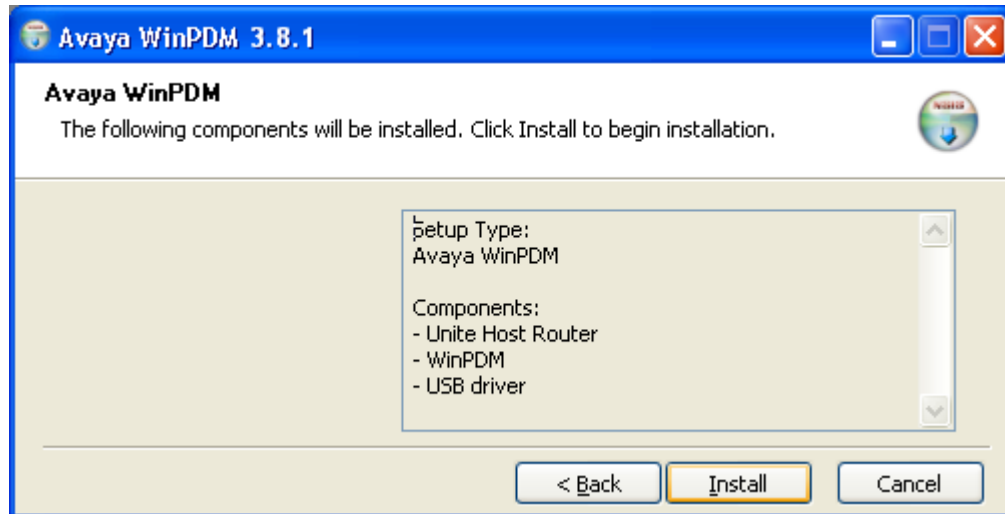

6. When the installation is complete, click on **Finish**.

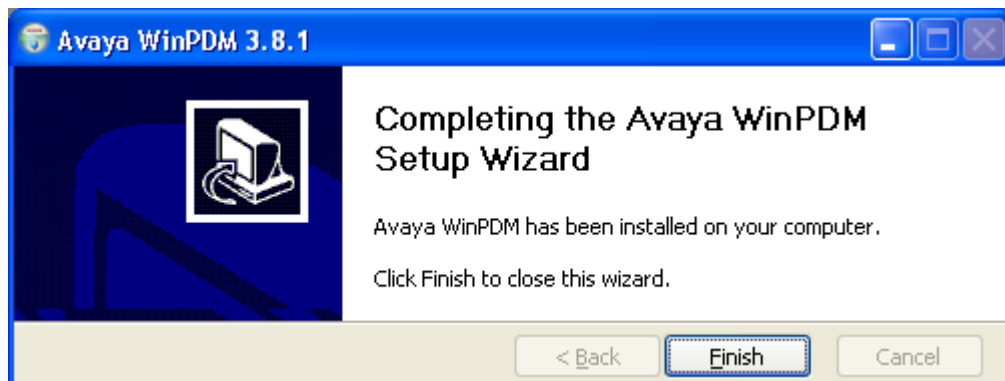

Related links

[Upgrading Phone Software](#) on page 165

Starting Windows Device Manager

Procedure

1. Select **Start > All Programs > Avaya WinPDM**.
2. Click on the **Avaya WinPDM** icon.
 - If this is the first time you have run Avaya WinPDM:
 - Avaya WinPDM will ask you to create a site. Enter a name for the site and click **OK**.
 - Avaya WinPDM will prompt you to import parameter definition files.

Related links

[Upgrading Phone Software](#) on page 165

Upgrading Phone Software

About this task

Avaya Wireless DECT is supported on a range of Avaya systems. For IP Office operation, you must use software specifically documented as tested and supported with IP Office. Details of supported software is included in the IP Office Technical Bulletin for each release.

Procedure

1. Within the Avaya Device Manager, select the **Devices** tab.

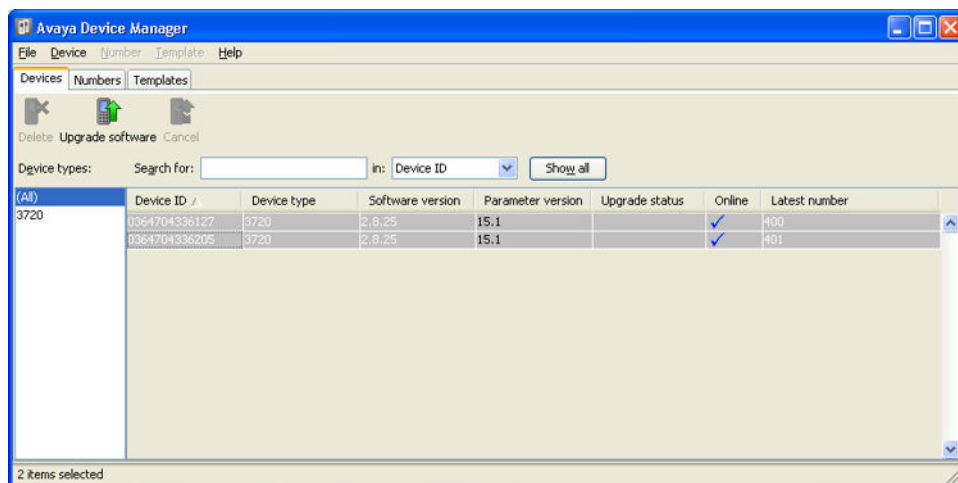

- The current software version of each phone is shown. Compare this to the software versions available, shown by the version set as part of the .pkg file name included with the Avaya Wireless DECT software.

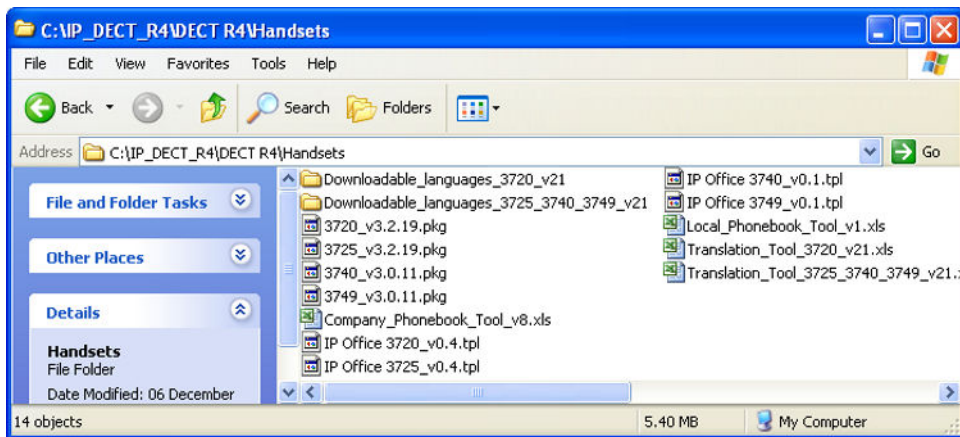

- In the device manager, select the phones that you want to upgrade.
- Click **Upgrade Software**. The menu shown depends on whether you are using the AIWS for an over-the-air upgrade or WinPDM for an in-charger upgrade.

- **AIWS Upgrade Software Menu**

This menu is shown when using the AIWS based device manager to upgrade phones over the air. This method supports a number of additional options but is much slower than upgrading phones in an advanced charger.

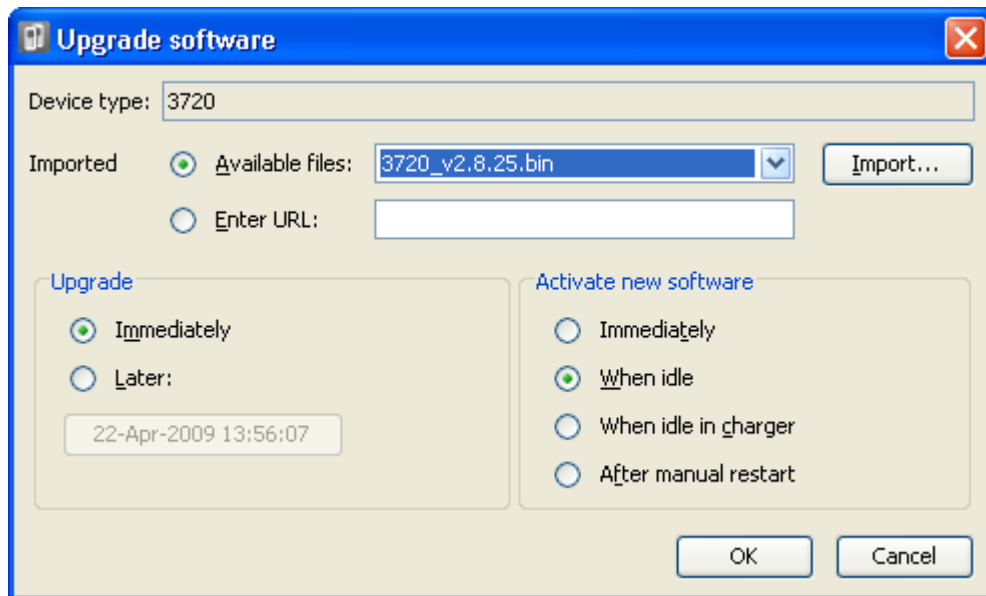

- **Advanced Charger/WinPDM Upgrade Menu**

Upgrading Phone Software

This menu is shown when using the Windows based device manager to upgrade a phone currently in an advanced charger connected to the PC by USB or LAN. See [Installing Windows Device Manager](#) on page 117.

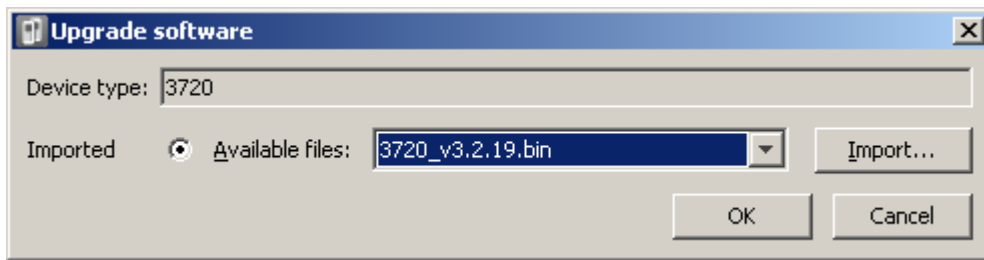

- If you have already imported the parameter definition files for the phones, use the **Available Files** drop-down to select the software bin file for the type of phone being upgraded. Otherwise click on **Import** and browse to the .pkg files for the phone type.
- Select the other upgrade settings required and click **OK**.

The upgrade begins. The following images show a typical upgrade as it is being performed on a 3720 device.

(All)	Device ID /	Device type	Software version	Parameter version	Upgrade status	Online	Latest number
3720	0364704336127	3720	2.8.25	15.1	Downloading	✓	400
	0364704336205	3720	2.8.25	15.1	Downloading	✓	401

(All)	Device ID /	Device type	Software version	Parameter version	Upgrade status	Online	Latest number
3720	0364704336127	3720	2.8.25	15.1	12%	✓	400
	0364704336205	3720	2.8.25	15.1	12%	✓	401

(All)	Device ID /	Device type	Software version	Parameter version	Upgrade status	Online	Latest number
3720	0364704336127	3720	2.8.25	15.1	Complete	✓	400
	0364704336205	3720	2.8.25	15.1	Complete	✓	401

Related links

[Upgrading Phone Software](#) on page 165

Part 9: AIWS Installation

Chapter 21: AIWS Installation

The AIWS (*Avaya In-Building Wireless Server*) unit supports several functions:

- It allows SMS messaging between handsets.
- It also allows wireless software upgrades and configuration of the handsets. Without an AIWS, handsets can only be upgraded and configured when in an advanced charger or a rack charger.
- For IP Office R5, the AIWS provides directory integration between the IP Office and the Avaya Wireless DECT system.
 - This requires the IP Office security settings to allow **TFTP Directory Read (Unsecured Interfaces)**.
 - On Linux-based IP Office servers, the **Solution > ☰ > Platform View > Settings > System > Firewall Settings** must allow access using port 69.
- For IP Office R6 and higher, the master base station does directory integration when an AIWS is not present. However, if SMS is required, the AIWS is used for both functions.

The unit is managed using a web browser and requires a fixed IP address.

Related links

- [Pre-Requisites](#) on page 173
- [Parts Required](#) on page 173
- [Information](#) on page 173
- [Tools](#) on page 174
- [Removing the AIWS Cover](#) on page 174
- [Image Installation Mode](#) on page 176
- [Connecting the RTC Battery](#) on page 177
- [Connecting Cables to an AIWS](#) on page 177
- [Accessing the AIWS Interface](#) on page 178
- [Running the Setup Wizard](#) on page 179
- [Enabling Base Station/AIWS Connection](#) on page 186
- [Upgrading the AIWS Firmware](#) on page 188
- [Switching Off the AIWS](#) on page 194
- [Mounting the AIWS on a Wall](#) on page 194
- [Replacing the AIWS Cover](#) on page 195

Pre-Requisites

- Master base station installed and connected to the network.
- IP Office connected to the network.
- Phones subscribed.

Related links

[AIWS Installation](#) on page 172

Parts Required

- AIWS Unit which includes:
 - AIWS Unit
 - AIWS Power Supply unit and selection of IEC60320 C7 power leads (CEE7/16 (Europlug), BS1363, NEMA1-15 and AS/NZS 3112).
 - 1.2 metre (4 foot) LAN cable
If this is replaced with a longer cable the replacement should be a CAT5 Ethernet LAN cable.
 - AIWS License sheet.
 - 3 x 3.5mm Screws and suitable wall plugs for the wall mounting of the AIWS.
 - LAN Socket
 - Mains power outlet socket.

Related links

[AIWS Installation](#) on page 172

Information

- IP Address for the AIWS.
- Other standard network settings (Default Gateway, DNS, WINS).
- AIWS License Key (this should have been supplied with the AIWS).
- IP Address of the DECT Master base station.
- IP Address of the IP Office.
- Preferred time settings (date format, time format).
- Wall mounting location selected for the AIWS.
- Access information (name and password) for configuring the base stations.

Related links

[AIWS Installation](#) on page 172

Tools

- Programming PC with Avaya Wireless DECT software.
- Web browser.
- Pliers and sharp knife for removal of plastic cable cut-outs from AIWS case.
- Drill and drill bits suitable for the selected wall mounting position of the AIWS.
- Screwdrivers for use with the screws selected for AIWS wall mounting.

Related links

[AIWS Installation](#) on page 172

Removing the AIWS Cover

About this task

The AIWS cover can be removed without using any tools.

Procedure

1. On the base of the unit (opposite the rounded end) are two depressible clips. Depress these while lifting the cover.

2. It should be possible to lift the cover off the unit.

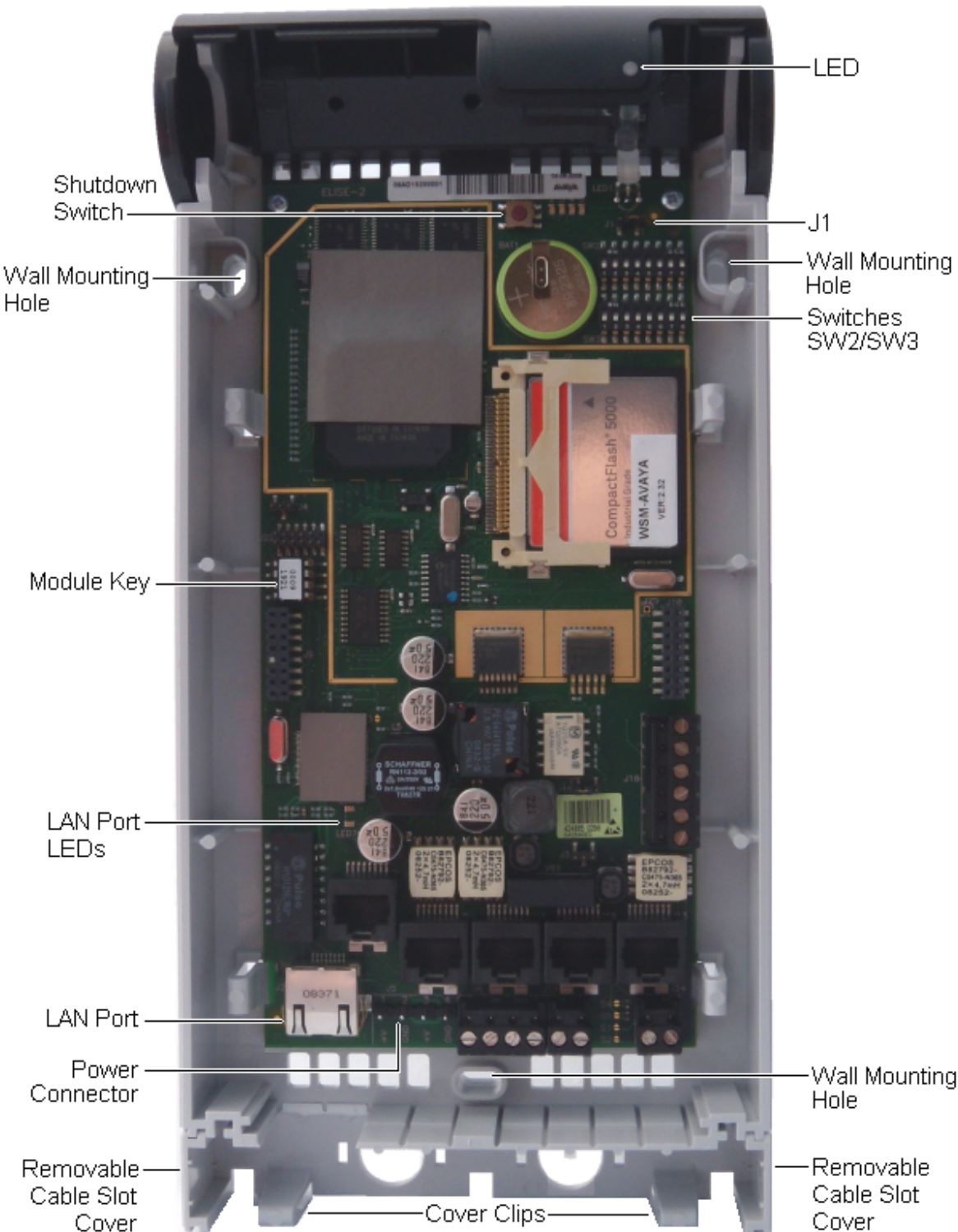

3. With the cover removed, familiarize yourself with the various features labeled above. These will be referred to during other parts of the installation process.

Related links

[AIWS Installation](#) on page 172

Image Installation Mode

About this task

This is the maintenance process to put an AIWS into Image Installation mode. The maintenance process is used to upload a .img file to the AIWS1 unit.

Procedure

1. Remove the AIWS cover.
2. Looking at the AIWS without the cover, the status LED should be towards the upper right corner.
3. Beneath it there should be two rows of small switches, to the right of the round battery.
4. The bottom one is of interest. As a way of being sure, there should be a mark on the board right next to it saying **SW3**.
5. All the switches should be marked with numbers in range 1 to 8, there should also be a mark **ON**.
6. Set only the switch labeled 4 to **ON**, the rest to **OFF**.
7. Reboot the AIWS. A reboot from the browser does not have a waiting time, so is preferred. If unable to do that:
 - a. Press the small button above and a bit to the left of the round battery on the AIWS circuit board. The press does not have to be long, a short one will do.
 - b. There is a 10 minute waiting time when doing so, in addition to the actual shutdown and startup of the AIWS.
8. Access the AIWS through the web browser. Do not type https in the address bar in image installation mode, as it only works with http.
9. Select the image file and upload it.
10. Set the AIWS back to normal mode.
11. Set the switch labeled 4 back to OFF to be the same as the rest.
12. Reboot the AIWS, preferably from the browser again.
13. You must reconfigure the AIWS settings. Although the IP address should have not been changed, if having trouble accessing it try the following:
 - a. Setting the AIWS in network mode by turning the switch labeled **1** to **ON**.

- b. Reboot the AIWS.
- c. The status LED should be steady amber (not blinking at all).
- d. Access the AIWS by the reserved IP address **192.5.36.229**.
- e. Enter the desired IP settings.
- f. Set the AIWS into normal mode by turning switch **1** back to **OFF**.
- g. Reboot the AIWS.
- h. Access the AIWS using the newly entered LAN settings.

Related links

[AIWS Installation](#) on page 172

Connecting the RTC Battery

The AIWS circuit board includes a 3V lithium battery which will keep the boards real time clock (RTC) running when power to the AIWS is off. The AIWS is shipped with the battery disconnected. To connect the battery, locate the switch **J1** at the top right of the board. Move the switch jumper to position 2-3.

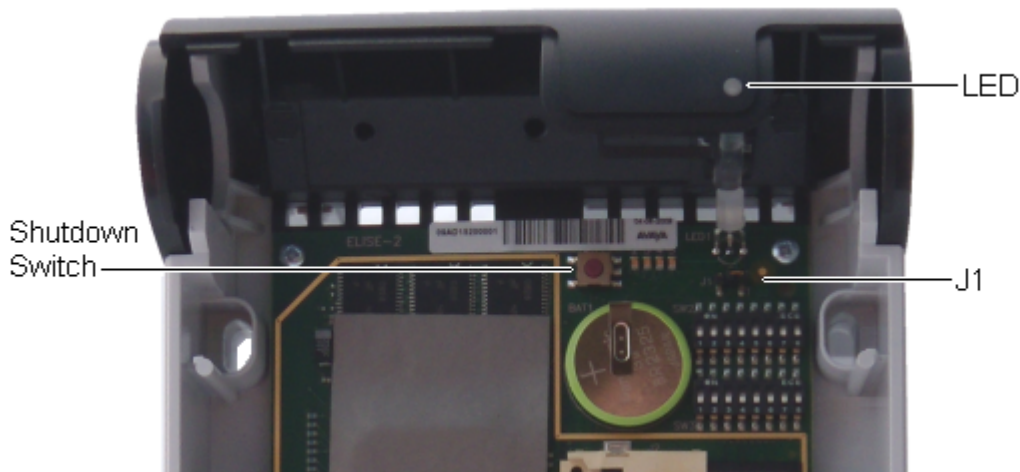

Related links

[AIWS Installation](#) on page 172

Connecting Cables to an AIWS

Procedure

1. Locate the switch sets **SW2** and **SW3** at the top-right of the AIWS circuit board. Ensure that all the switches are set to **Off**.

2. Locate the LAN port and the J5 power connector. Just below these is a plastic panel. With care remove sufficient parts of the panel to allow cable access to the LAN port and power connector when the AIWS cover is put back.

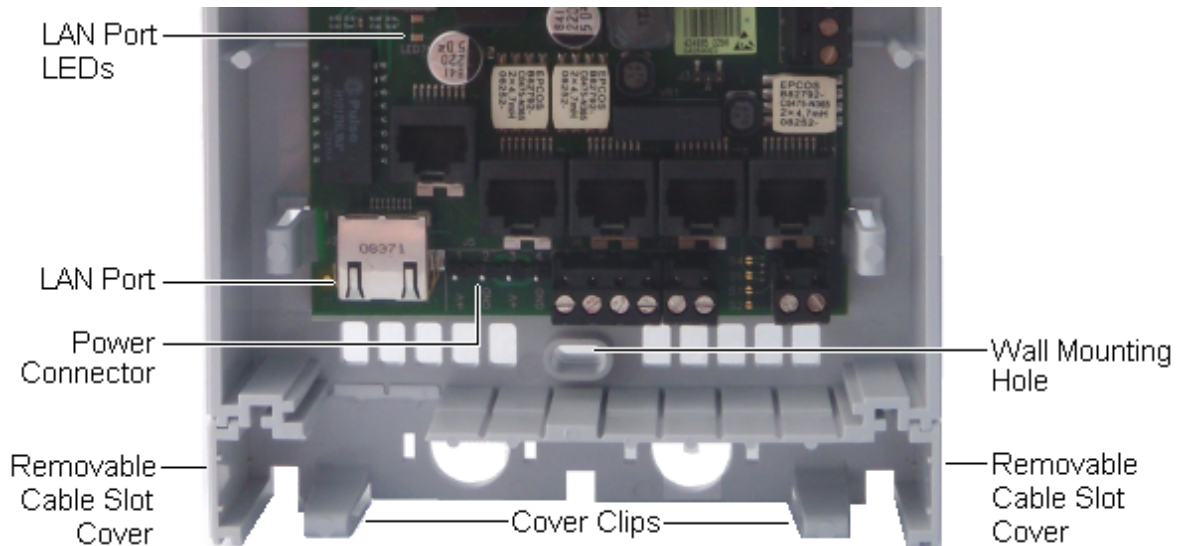

3. Connect the LAN cable from the IP Office to the AIWS.
4. Connect the power supply cable to the J5 power connector next to the AIWS LAN port.
5. Switch on power to the AIWS unit.

Related links

[AIWS Installation](#) on page 172

Accessing the AIWS Interface

About this task

The AIWS can be accessed using a web browser.

Procedure

1. Enter the IP address of the AIWS into the browser address field.
Alternatively enter `http://Elise-0091921` as the address, replacing the digits with the AIWS unit's Module Key. The Module Key is printed on the AIWS circuit board
2. If a security certificate warning appears, select it to continue.
3. Enter a user name and password. The default values are **admin** and **changeme**.

The AIWS menu is shown:

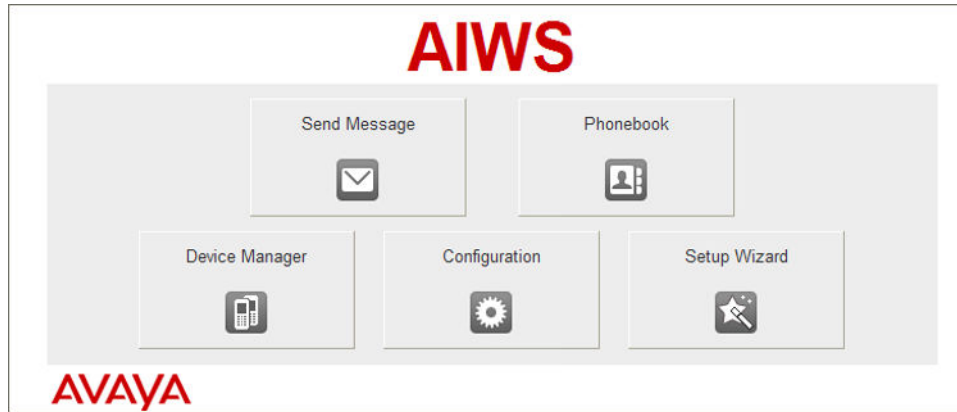
**Related links**

[AIWS Installation](#) on page 172

Running the Setup Wizard

About this task

The first time the AIWS is accessed it runs the setup wizard.

Procedure

1. Access the AIWS using your browser.

2. If the unit is defaulted, the setup wizard runs automatically. If the unit already has configuration settings, then from the menu displayed select **Setup Wizard**.

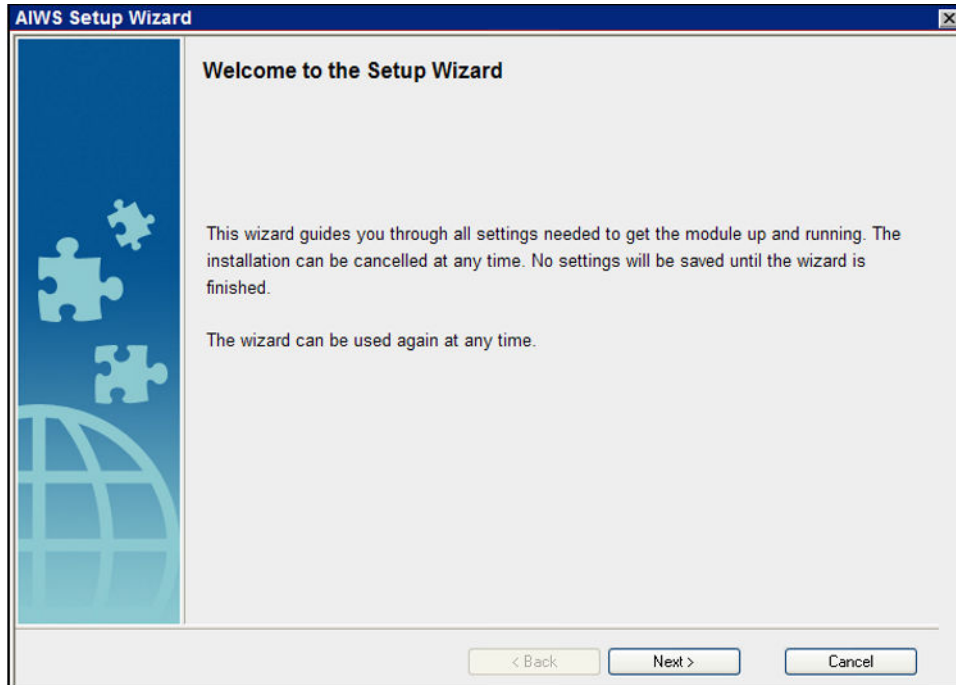

3. Click **Next**.

4. Enter the network address settings for the AIWS unit.

AIWS Setup Wizard

Network Setup

In a system with a DHCP server, the network parameters can be set automatically, otherwise the parameters have to be set manually.

Select how to set the network parameters

Automatically (DHCP)

Manually

Network Parameters

Host Name	AIW	?
IP Address	192.168.42.211	?
Subnet Mask	255.255.255.0	?
Default Gateway	192.168.42.1	?
Domain Name	example.com	?
DNS Server	192.168.42.1	?
WINS Server	0.0.0.0	?

< Back Next > Cancel

- Set the network parameters mode to **Manually**.
- **Host Name**
Enter a name to help identify the AIWS on the network.
- **IP Address/Subnet Mask**
Enter the static IP address details that the AIWS should use.
- Set the remaining details to match those being used by other devices on the network.
- Click **Next**.
- Enter the license number supplied with the AIWS unit and click **Next**.

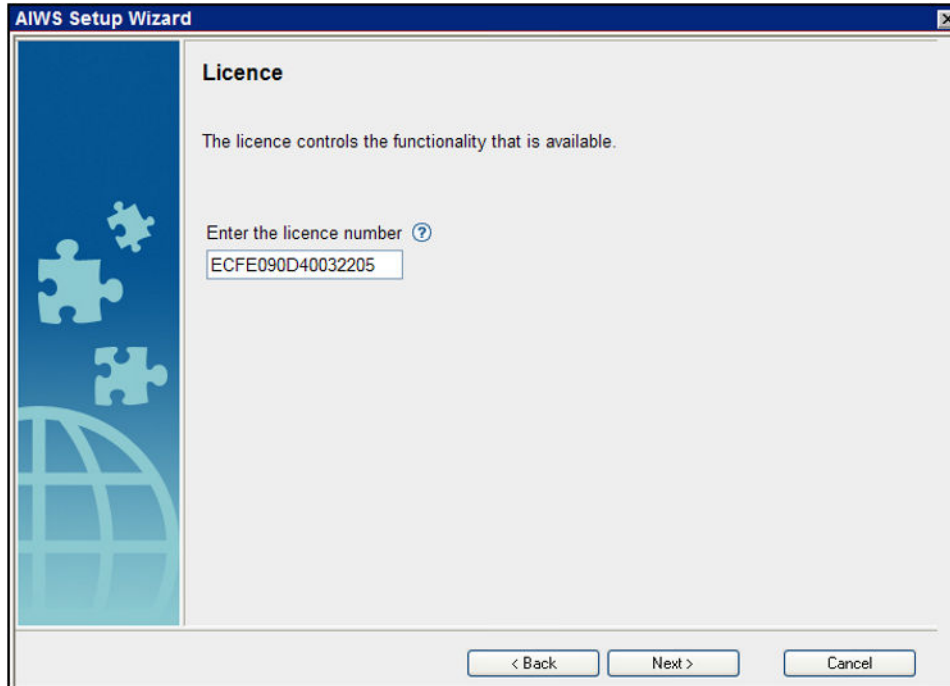

- Enter the IP address of the master base station and click **Next**.

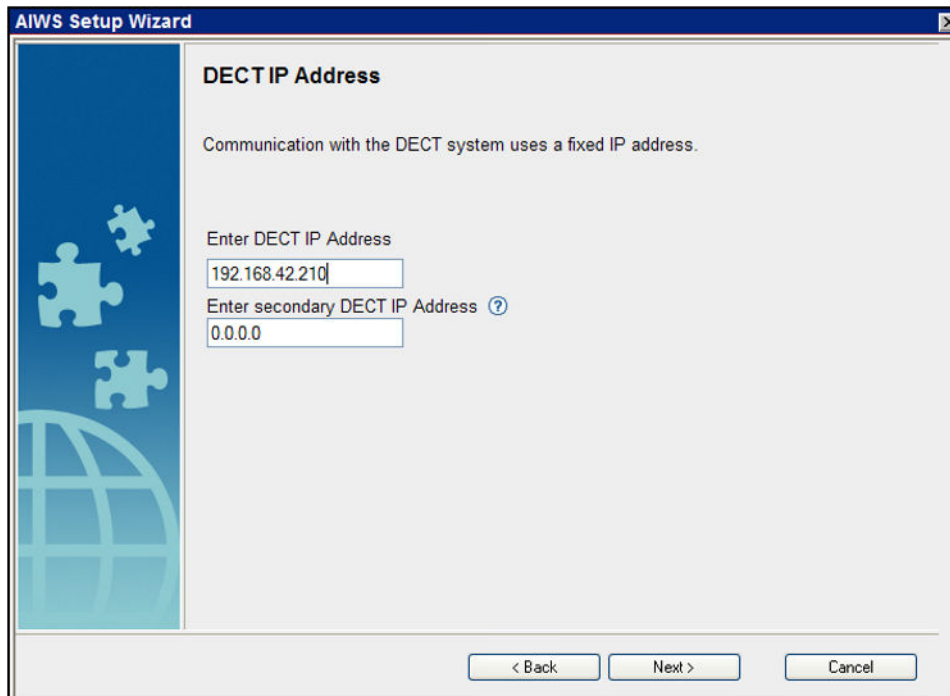

- The **Date and Time** options are displayed. Select **NTP Time Server** and set the **Time Server IP Address** to be the IP address of the IP Office. Adjust the other values to match the customer site.

- Click **Next**. The **Phonebook Properties** options are displayed.
- Select **TFTP**, in order to have the AIWS obtain the phone book from the IP Office, and then click **Next**.

- Set the **TFTP Server IP** to the IP address of the IP Office and click **Next**.

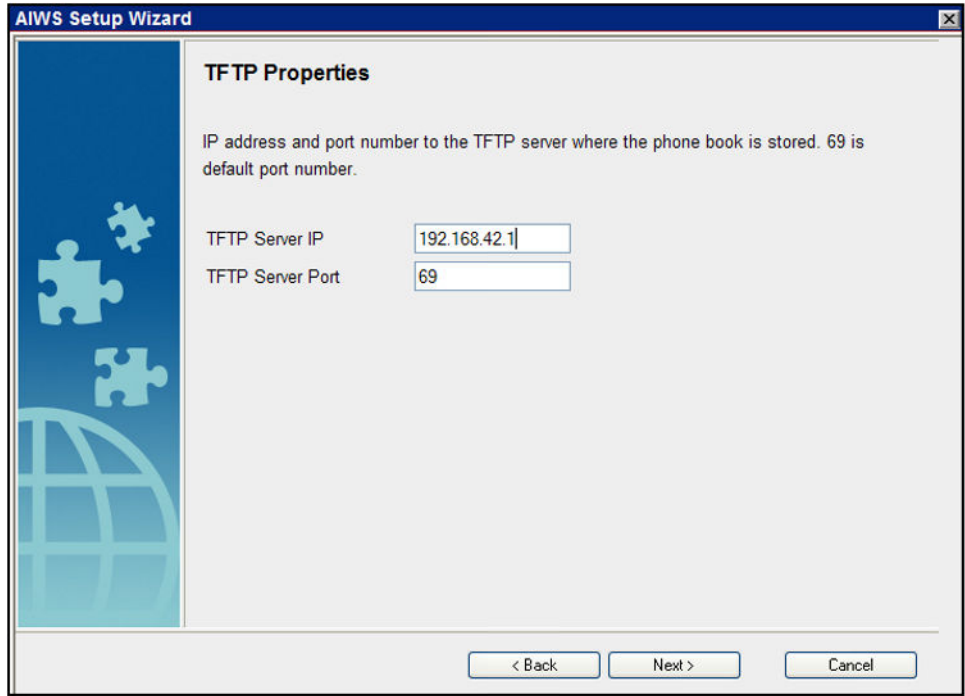

- If necessary, change the default passwords and click **Next**.



- Click **Finish** to save the settings.

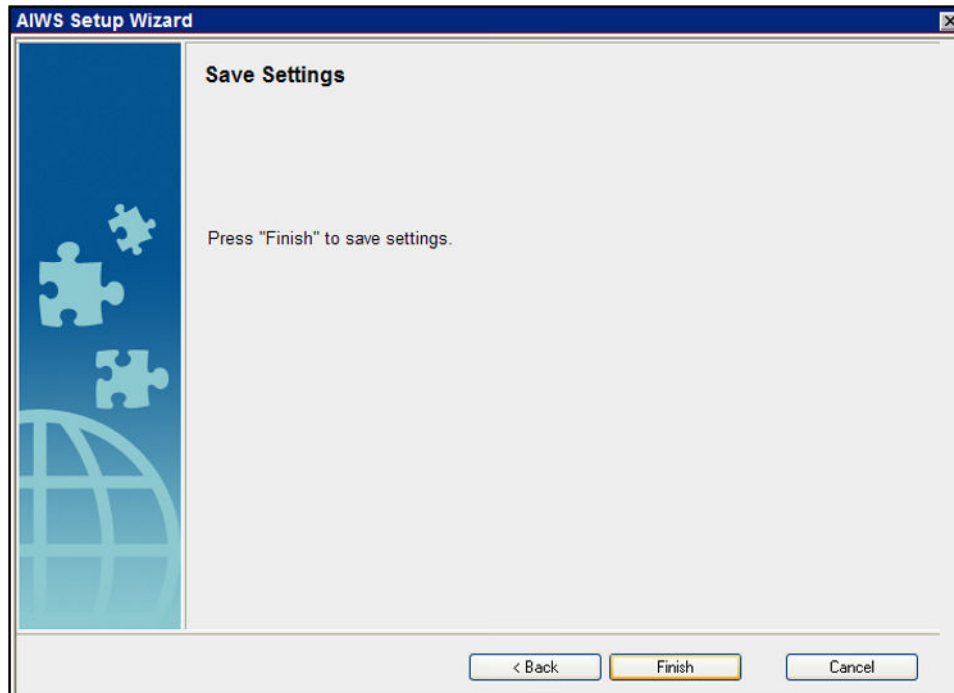

- Click **Restart Now**.

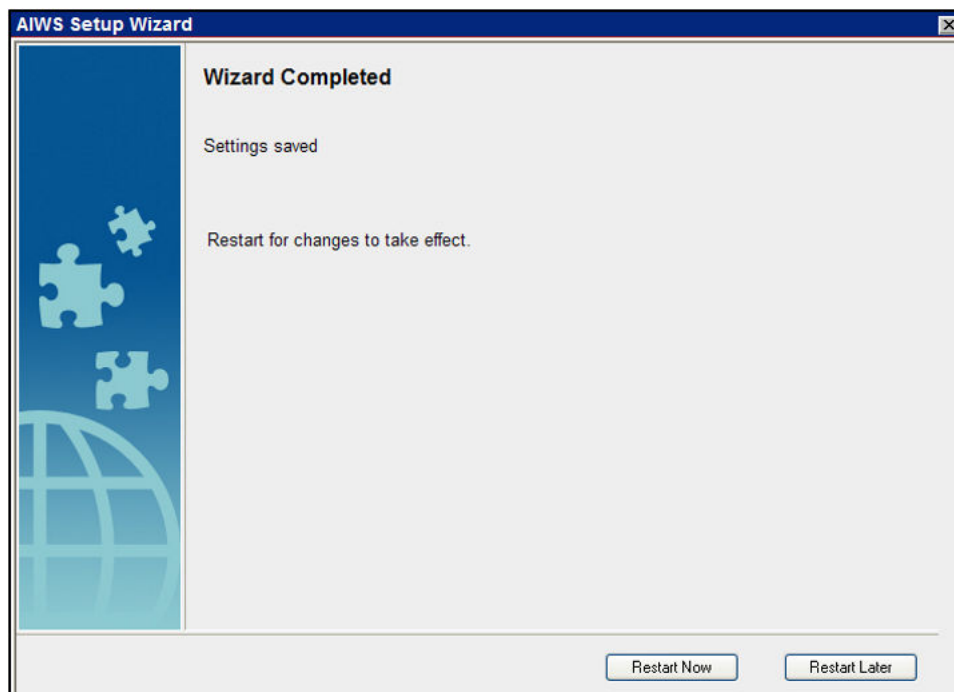

- Close the browser access session. Start a new session using the new IP address.

Related links

[AIWS Installation](#) on page 172

Enabling Base Station/AIWS Connection

About this task

The IP address of the AIWS needs to be entered into the configuration of the base stations.

Related links

[AIWS Installation](#) on page 172

[Configuring the AIWS DECT Connection \(Master Only\)](#) on page 186

[Enabling Status Log \(Master and Slave\)](#) on page 187

Configuring the AIWS DECT Connection (Master Only)

About this task

If the system includes an AIWS, use the following procedure to configure the base station to sync with the AIWS.

If no AIWS is present, proceed to [Phonebook Integration](#) on page 91.

Procedure

1. Select **Services**.
2. Select **Phonebook** and disable the phonebook option.

Configuration	Update	Logging	HTTP	HTTP Client	SNMP	Provisioning	Phonebook	Logout
General								
LAN								
IP								
LDAP								
DECT								
VoIP								
Unite								
Services								
Administration								
Users								
Device Overview								
DECT Sync								
Traffic								

Enable

General Settings

Search Direction Numbers

Phonebook Number

TFTP Settings

Server IP Address

External Directory File

Internal Directory File

Synch. Interval [min]

3. Click **OK**.
4. Select **UNITE**.

5. Select the **Device Management** tab.

Configuration	SMS	Device Management	Service Discovery	Status Log	Logout
General					
LAN					
IP					
LDAP					
DECT					
VoIP					
Unite					
Services					
Administration					
Users					
Device Overview					
DECT Sync					

Portable Devices Active Settings

IP Address

IP-DECT Devices Active Settings

Unite IP Address

Unite Resource Identity

Unite Address

6. For the **Unite IP Address**, enter the IP address that will be assigned to the AIWS unit when installed in the DECT system.
7. Click **OK** and reset the master base station.

Related links

[Enabling Base Station/AIWS Connection](#) on page 186

[Enabling Base Station/AIWS Connection](#) on page 205

Enabling Status Log (Master and Slave)

Procedure

1. In the left-hand panel, select **UNITE**. Select the **Status Log** tab.

Configuration	SMS	Device Management	Service Discovery	Status Log	Logout
General					
LAN					
IP					
LDAP					
DECT					
VoIP					
Unite					

Unite IP Address

Unite Resource Identity

2. For the **Unite IP Address**, enter the IP address that will be assigned to the AIWS unit when installed in the DECT system.
3. For the **Unite Resource Identity** enter a unique name to be associated with the base station.
4. Click **OK**.
5. Select the **SMS** tab. Again enter the IP address that will be assigned to the AIWS unit when installed in the DECT system.
6. Click **OK**.

Related links

[Enabling Base Station/AIWS Connection](#) on page 186

[Enabling Base Station/AIWS Connection](#) on page 205

Upgrading the AIWS Firmware

About this task

The AIWS is supplied with a default set of firmware. This must be upgraded to the firmware version provided with the IP Office application software. Only the firmware supplied with the IP Office application software or indicated in IP Office Technical Bulletin should be used with AIWS units on IP Office Avaya Wireless DECT systems.

- **Important:** This process can take up to 40 minutes.

Procedure

1. Using a browser login to the unit.
2. Click on **Configuration**.



3. Note the software version. Check whether this already matches the firmware detailed as supported by the level of software on the IP Office system.
4. In the browser address bar, change the `/config/start.php` part of the address to `/system`.
5. Click the **Software** button.

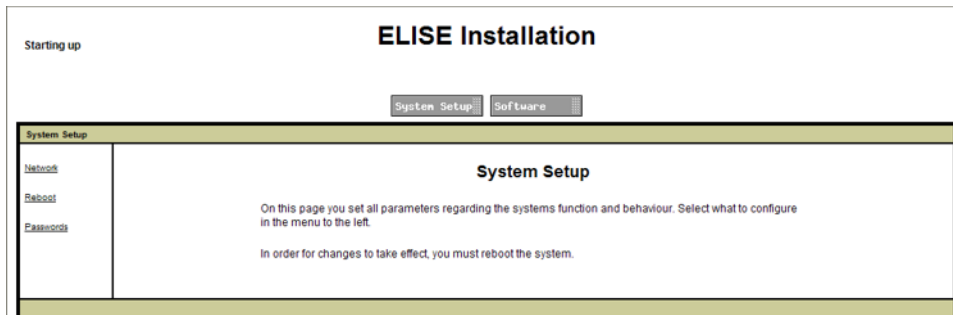

6. In the sidebar, click **Install Image**.

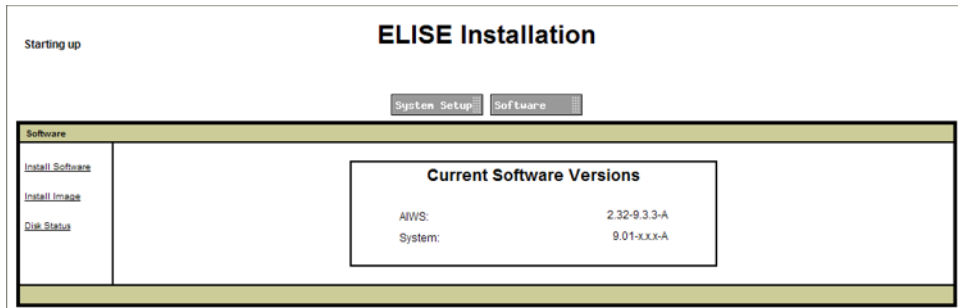

7. Click the **Backup parameters** button.

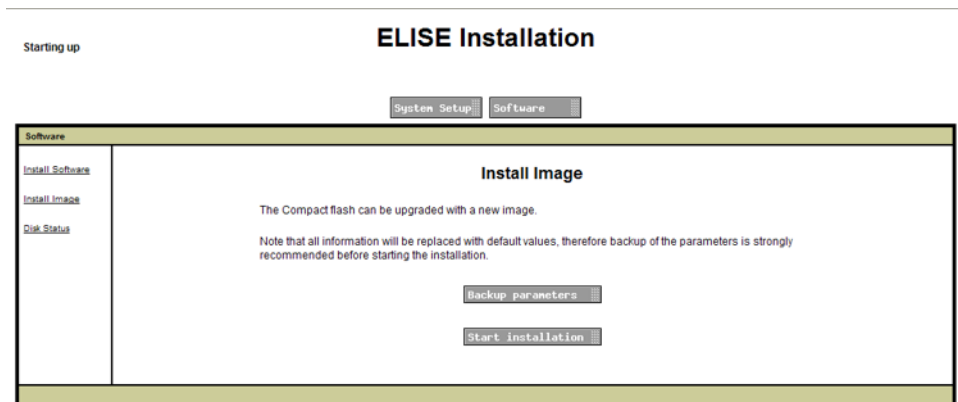

The browser shows a dialog for downloading a file called aiws-backup from the AIWS unit.

8. Select the option to save the file and select a save location. Make note of the location as the file needs to be reloaded after the firmware upgrade.
9. Click the **Start installation** button. A status and progress window appears:

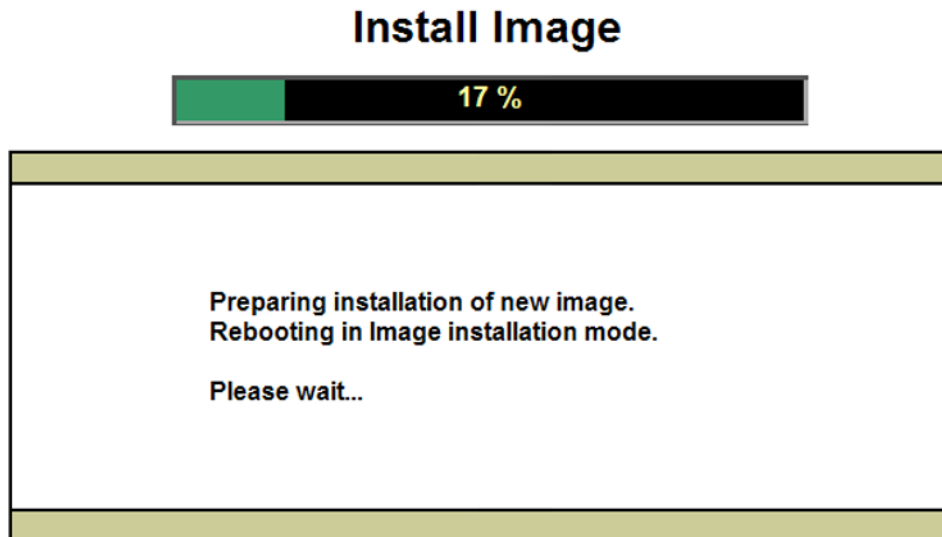

10. After a short delay, the AIWS prompts you for the location of the firmware file for the upload.

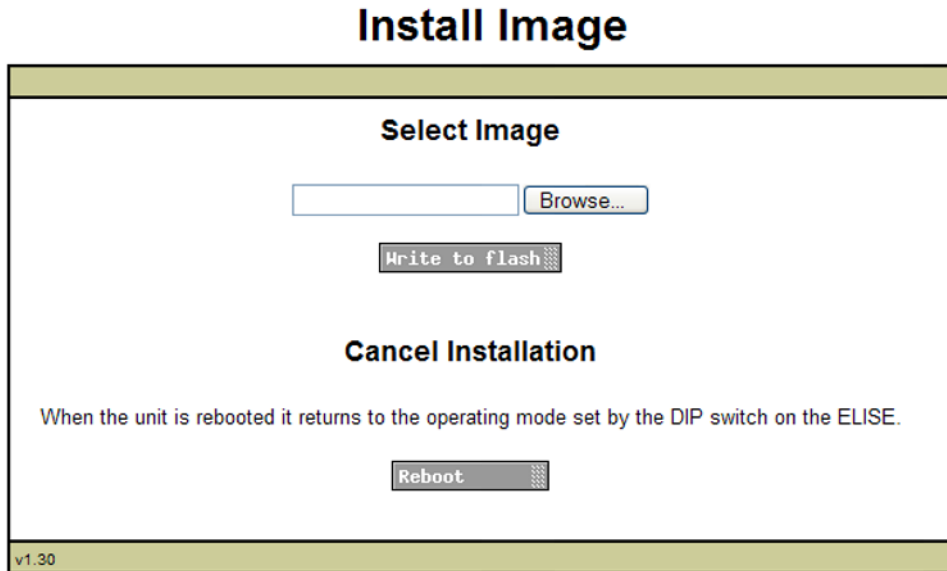

11. Click on **Browse**. Locate the AIWS folder in the software set previously unpacked. Select the .img file.

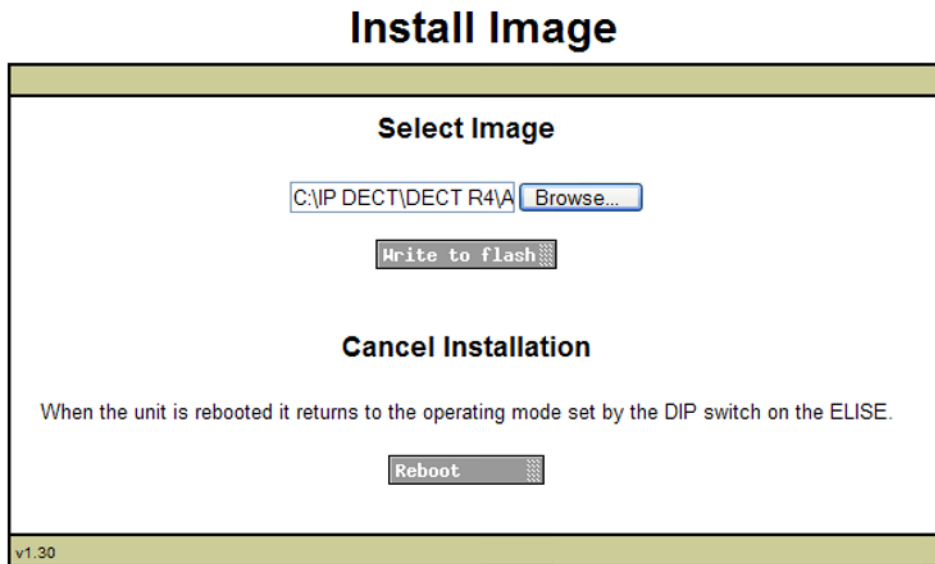

- Click the **Write to flash** button.

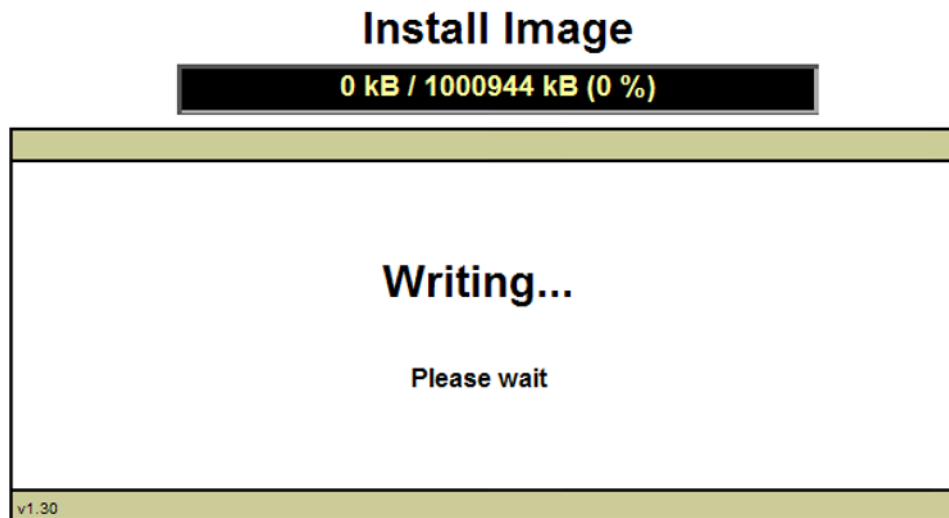

- Wait for the process to finalize. The process can be time consuming, but must be allowed to complete.

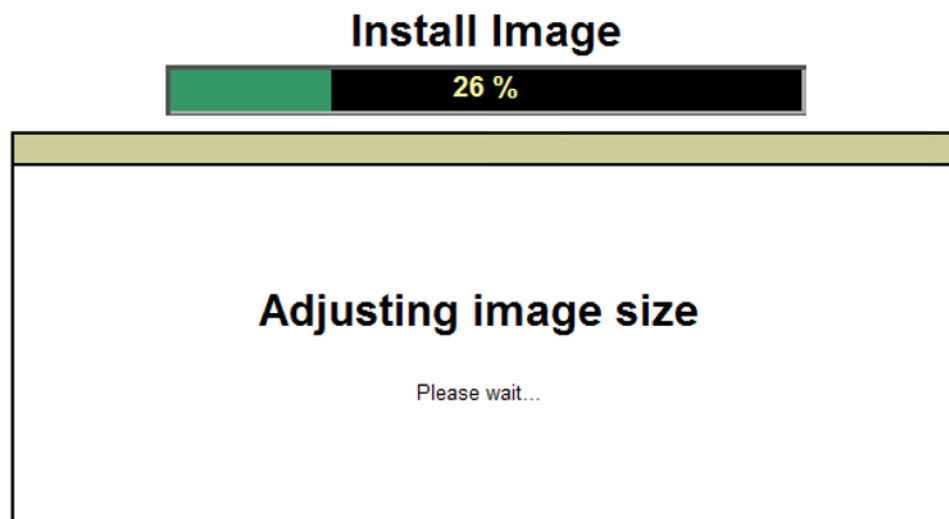

14. If the browser security warning is displayed, select to continue.

Install Image

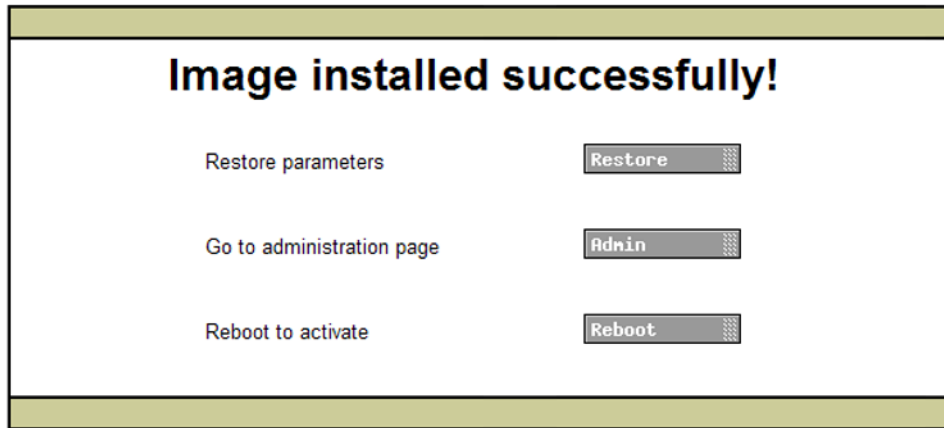

15. Click **Restore**. A separate window opens.
16. Select **Browse**, then locate and select the previously backed up aiws-backup file.

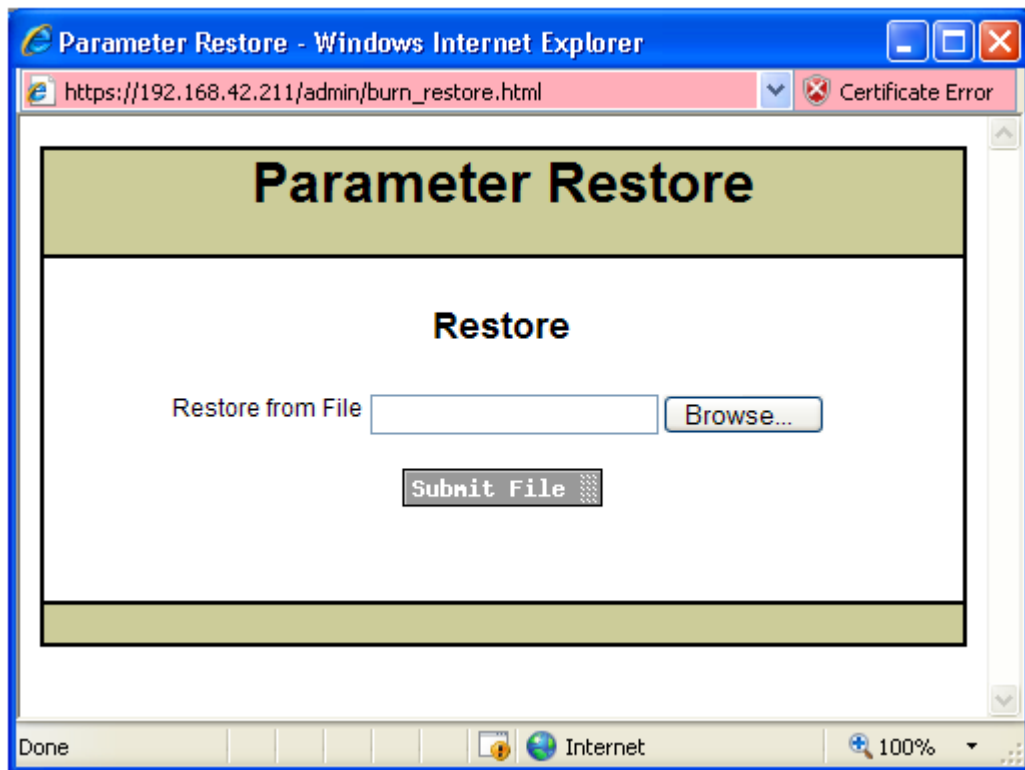

17. Click **Submit file**.

Parameter Restore

Restore

Restore from File

After the parameters are restored, a notification appears.

18. Click **Close**.

Parameters restored!

All parameters except network will take effect immediately.
For network parameters to take effect, the module needs to be restarted

19. Select **Reboot**.

Install Image

Image installed successfully!

Restore parameters

Go to administration page

Reboot to activate

Related links

[AIWS Installation](#) on page 172

Switching Off the AIWS

About this task

Having now configured and upgraded the AIWS, it should be switched off and disconnected prior to being wall mounted

Procedure

1. At the top right of the AIWS circuit board, locate the SW4 push button.
2. Press the button until the AIWS lamp starts to flash orange.
3. Remove the power cable. The power must be removed within ten minutes or the AIWS will restart. If the AIWS restarts, wait until the Function Indicator is not indicating starting up (flashing orange) before pressing the SW4 button again.

Related links

[AIWS Installation](#) on page 172

Mounting the AIWS on a Wall

The AIWS can be wall mounted. To facilitate service after the unit is installed, we recommend a free space of about 150 mm above and 50 mm below the unit.

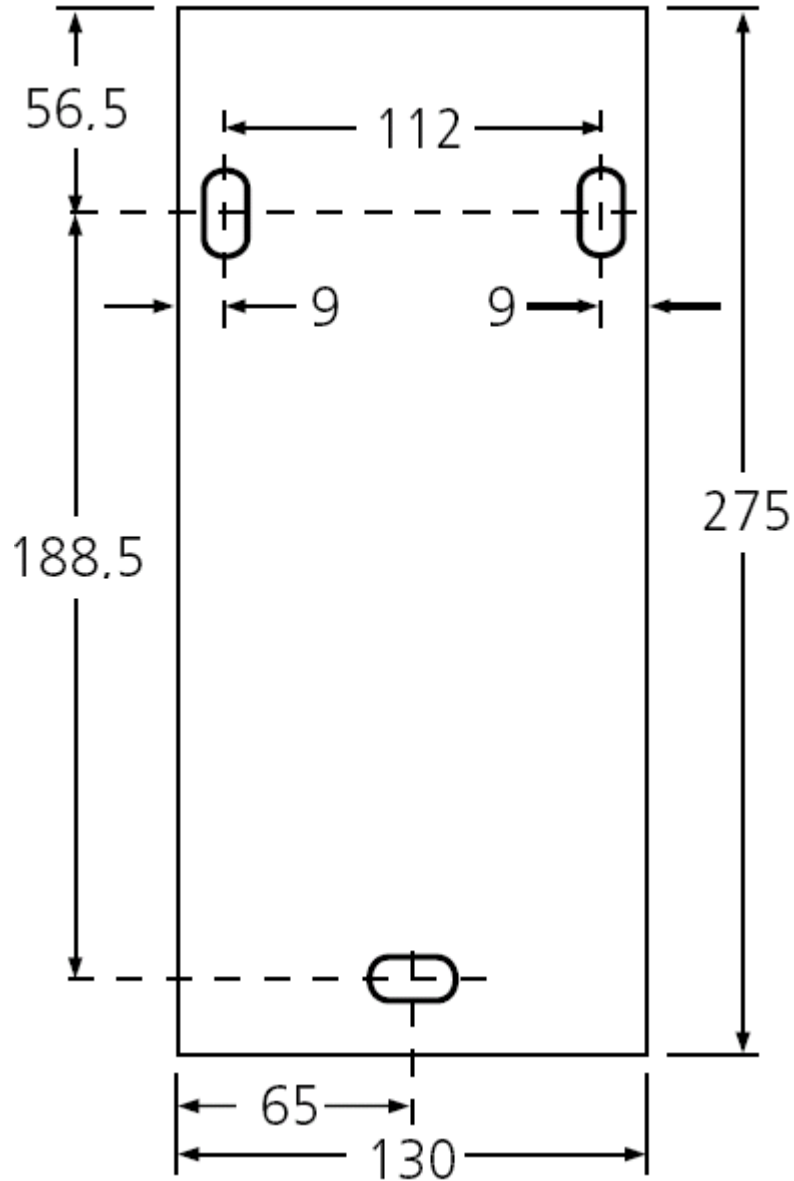

Related links

[AIWS Installation](#) on page 172

Replacing the AIWS Cover

About this task

The AIWS cover can be clipped back into place without using any tools.

Procedure

1. Check that the AIWS is fully operating (green lamp) and can be browsed from the network.
2. Check that the cables are routed such that they will not be trapped when the cover is replaced.
3. Engage the cover with the top edge of the AIWS. Pivot the cover back into position, checking that the various plastic edges are in their original positions.

The cover clips will spring into position.

Related links

[AIWS Installation](#) on page 172

Chapter 22: Installing an AIWS2

Related links

- [Browsing to the AIWS2](#) on page 197
- [Running the Setup Wizard](#) on page 198
- [Enabling Base Station/AIWS Connection](#) on page 205
- [Upgrading the AIWS Firmware](#) on page 207

Browsing to the AIWS2

By default the AIWS2 will obtain an IP address for the LAN 1 port using DHCP if possible. Using the unit's LAN 1 MAC address, printed on the back of the unit.

Related links

- [Installing an AIWS2](#) on page 197
- [Using the Network Connection](#) on page 197
- [Using the USB Management Connection](#) on page 198

Using the Network Connection

Procedure

1. Connect the AIWS2 unit to the LAN using the LAN 1 port on the rear of the unit.
2. Connect the appropriate power cable to the unit and switch on the power supply.
3. The Status LED should change to a fast flashing blue while the unit is starting up.
4. When the starting up indication stops, you can attempt to browse to the unit.
5. Enter the IP address of the AIWS into the browser address field.
 - Alternatively enter `http://elise-XXXXXXXX` as the address, where **XXXXXXXX** is the module key number printed on the back of the unit. Leading zeros can be omitted.
 - If a security certificate warning appears, select to continue.
 - Enter a user name and password. The default values are **admin** and **changeme**.
 - If this is the first time the AIWS2 has been started, the setup wizard is displayed. Otherwise the AIWS menu is shown.

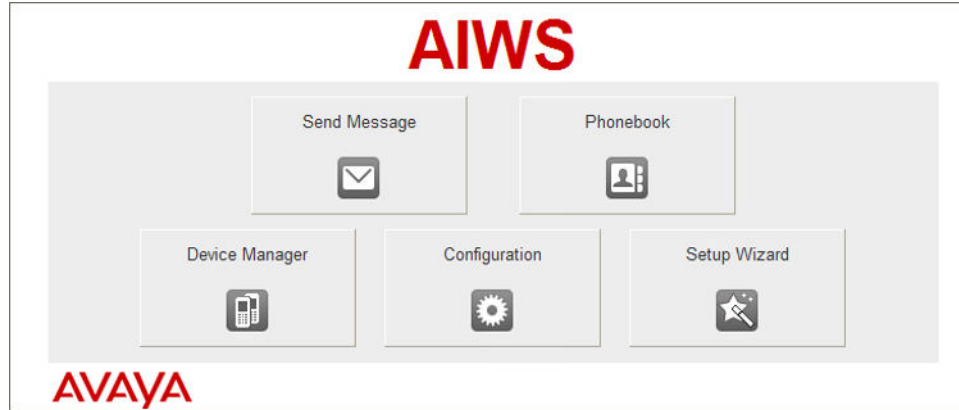

Related links

[Browsing to the AIWS2](#) on page 197

Using the USB Management Connection

The AIWS2 supports connection and administration via a USB cable connected to the **Management** port on the front of the unit. This requires the installation of a device driver that can be obtained from the unit by putting it into its **Mass Storage** mode. Full details for installation and use are provided in the documentation provided with the unit.

Related links

[Browsing to the AIWS2](#) on page 197

Running the Setup Wizard

About this task

The first time the AIWS is accessed it runs the setup wizard.

Procedure

1. Access the AIWS using your browser.

2. If the unit is defaulted, the setup wizard runs automatically. If the unit already has configuration settings, then from the menu displayed select **Setup Wizard**.

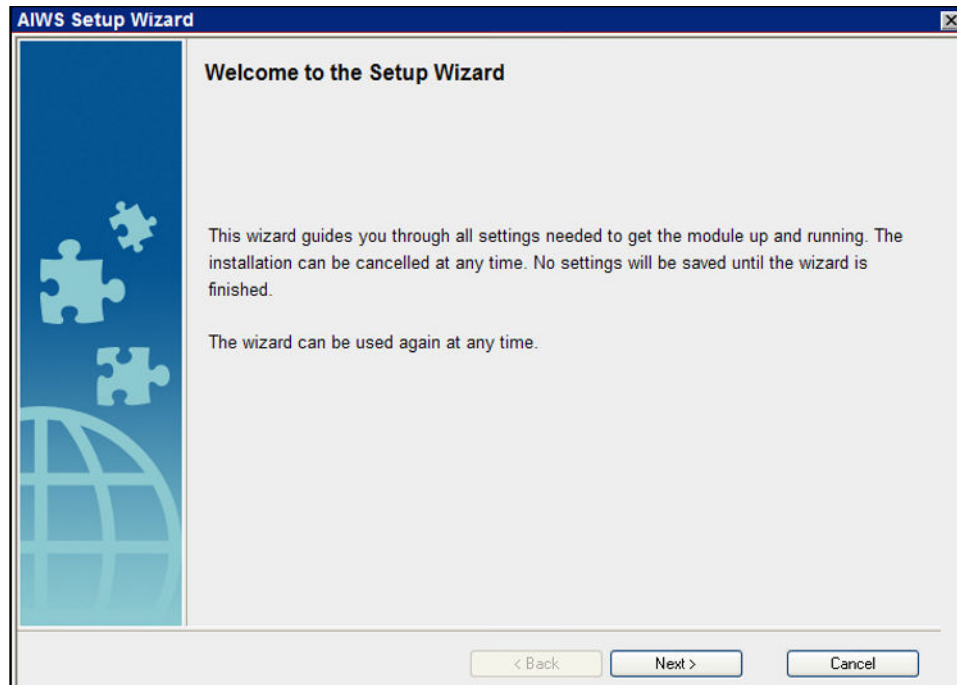

3. Click **Next**.

4. Enter the network address settings for the AIWS unit.

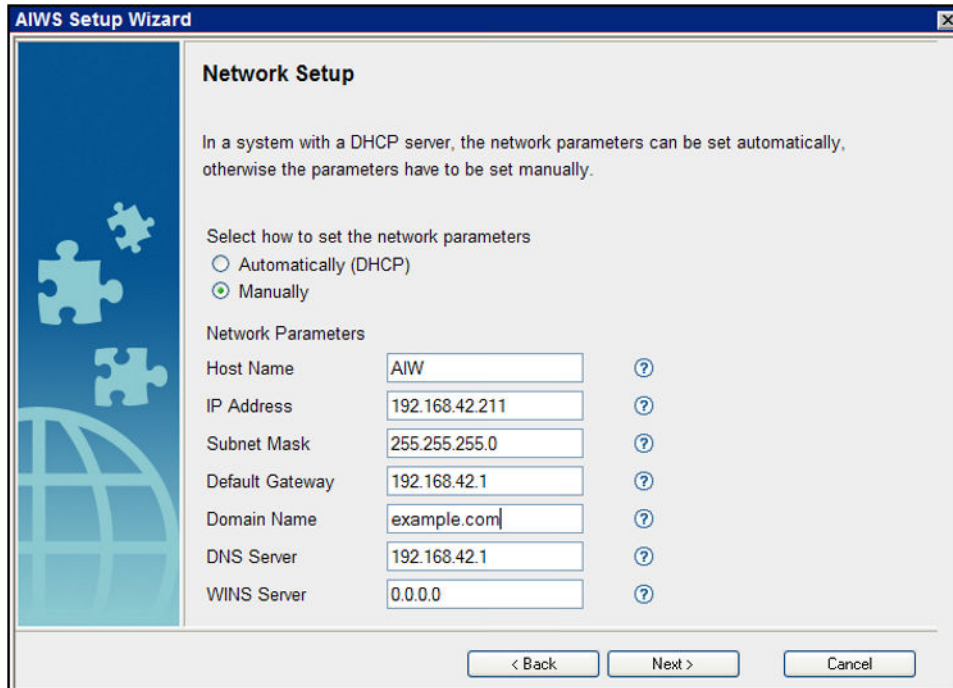

- Set the network parameters mode to **Manually**.
- **Host Name**
Enter a name to help identify the AIWS on the network.
- **IP Address/Subnet Mask**
Enter the static IP address details that the AIWS should use.
- Set the remaining details to match those being used by other devices on the network.
- Click **Next**.
- Enter the license number supplied with the AIWS unit and click **Next**.

Licence

The licence controls the functionality that is available.

Enter the licence number ?

ECFE090D40032205

< Back Next > Cancel

- Enter the IP address of the master base station and click **Next**.

DECT IP Address

Communication with the DECT system uses a fixed IP address.

Enter DECT IP Address

192.168.42.210

Enter secondary DECT IP Address ?

0.0.0.0

< Back Next > Cancel

- The **Date and Time** options are displayed. Select **NTP Time Server** and set the **Time Server IP Address** to be the IP address of the IP Office. Adjust the other values to match the customer site.

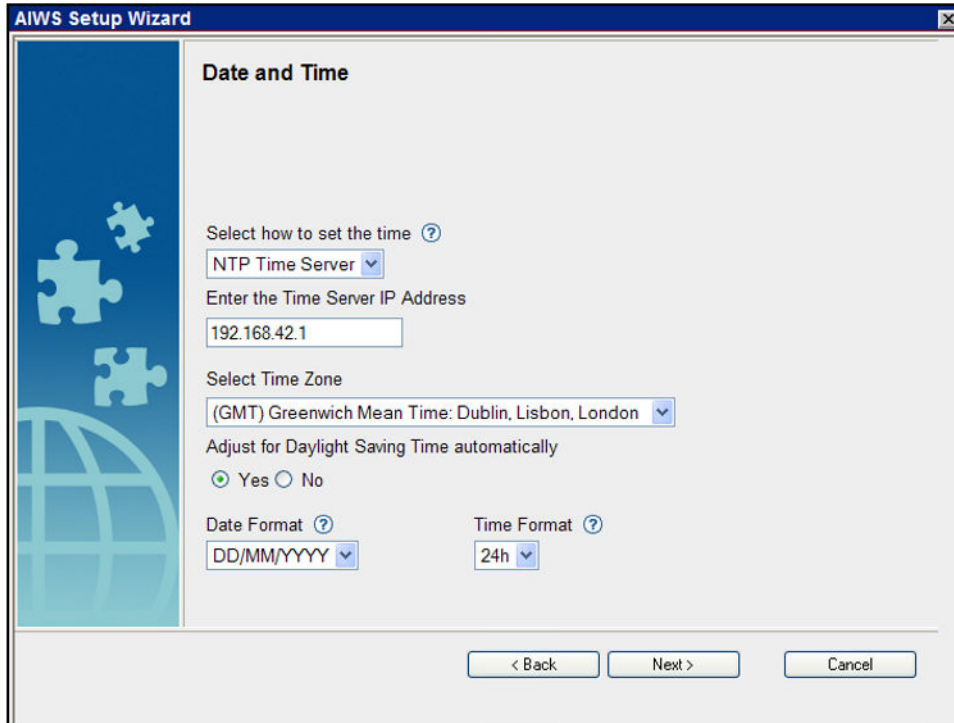

- Click **Next**. The **Phonebook Properties** options are displayed.
- Select **TFTP**, in order to have the AIWS obtain the phone book from the IP Office, and then click **Next**.

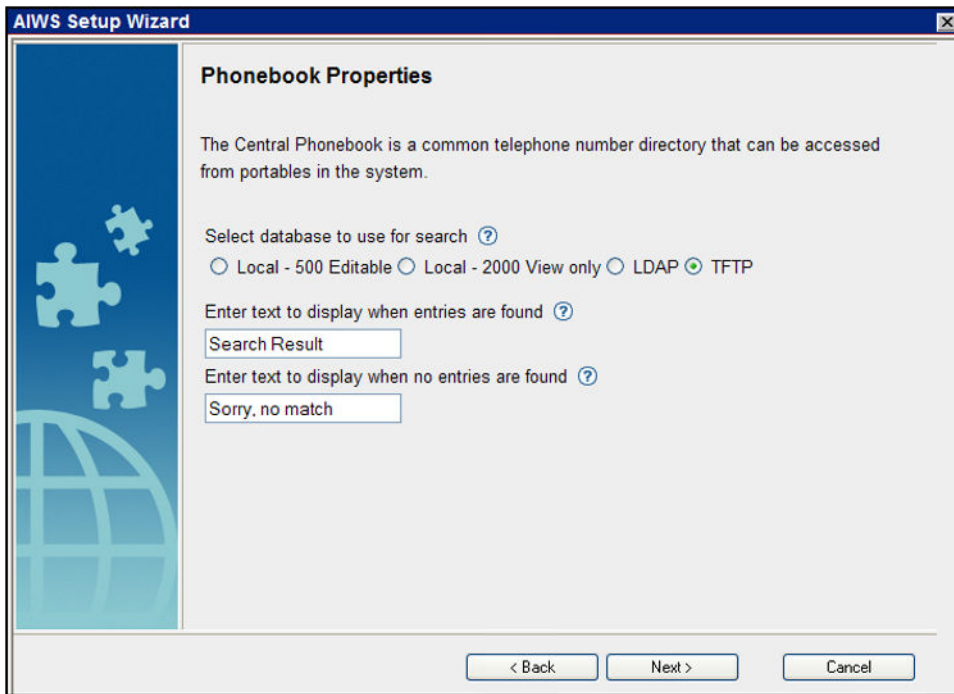

- Set the **TFTP Server IP** to the IP address of the IP Office and click **Next**.

AIWS Setup Wizard

TFTP Properties

IP address and port number to the TFTP server where the phone book is stored. 69 is default port number.

TFTP Server IP:

TFTP Server Port:

< Back Next > Cancel

- If necessary, change the default passwords and click **Next**.

AIWS Setup Wizard

Change Passwords

It is recommended to change default passwords. Leave text fields empty to keep current passwords.

Enter password for sysadmin:

Change Password for: [?](#)

sysadmin	?	<input type="text"/>	Verify Password	<input type="text"/>
admin	?	<input type="text"/>	Verify Password	<input type="text"/>
user	?	<input type="text"/>	Verify Password	<input type="text"/>
ftpuser	?	<input type="text"/>	Verify Password	<input type="text"/>

< Back Next > Cancel

- Click **Finish** to save the settings.

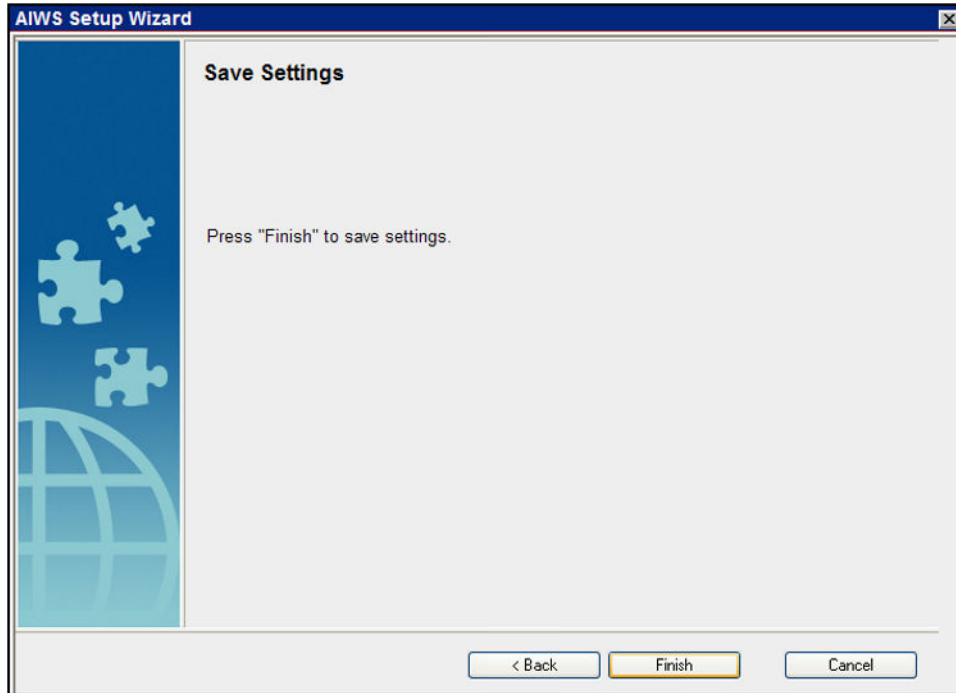

- Click **Restart Now**.

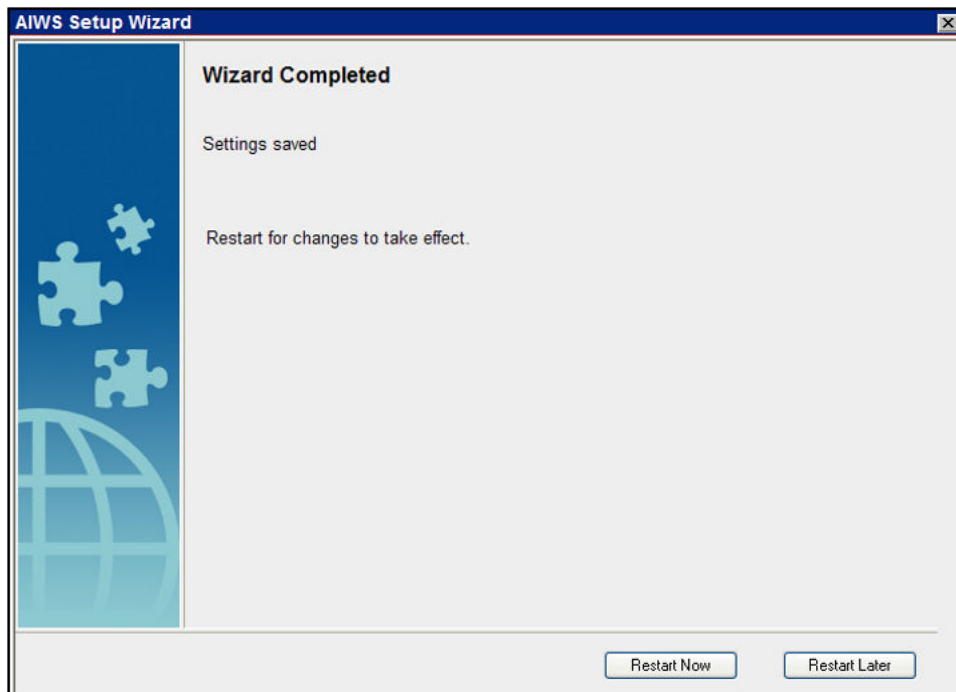

- Close the browser access session. Start a new session using the new IP address.

Related links

[Installing an AIWS2](#) on page 197

Enabling Base Station/AIWS Connection

The IP address of the AIWS needs to be entered into the configuration of the base stations.

Related links

[Installing an AIWS2](#) on page 197

[Configuring the AIWS DECT Connection \(Master Only\)](#) on page 186

[Enabling Status Log \(Master and Slave\)](#) on page 187

Configuring the AIWS DECT Connection (Master Only)

About this task

If the system includes an AIWS, use the following procedure to configure the base station to sync with the AIWS.

If no AIWS is present, proceed to [Phonebook Integration](#) on page 91.

Procedure

1. Select **Services**.
2. Select **Phonebook** and disable the phonebook option.

Configuration	Update	Logging	HTTP	HTTP Client	SNMP	Provisioning	Phonebook	Logout
General								
LAN								
IP								
LDAP								
DECT								
VoIP								
Unite								
Services								
Administration								
Users								
Device Overview								
DECT Sync								
Traffic								

Enable

General Settings

Search Direction Numbers

Phonebook Number

TFTP Settings

Server IP Address

External Directory File

Internal Directory File

Synch. Interval [min]

3. Click **OK**.
4. Select **UNITE**.

5. Select the **Device Management** tab.

6. For the **Unite IP Address**, enter the IP address that will be assigned to the AIWS unit when installed in the DECT system.
7. Click **OK** and reset the master base station.

Related links

- [Enabling Base Station/AIWS Connection](#) on page 186
- [Enabling Base Station/AIWS Connection](#) on page 205

Enabling Status Log (Master and Slave)

Procedure

1. In the left-hand panel, select **UNITE**. Select the **Status Log** tab.

2. For the **Unite IP Address**, enter the IP address that will be assigned to the AIWS unit when installed in the DECT system.
3. For the **Unite Resource Identity** enter a unique name to be associated with the base station.
4. Click **OK**.
5. Select the **SMS** tab. Again enter the IP address that will be assigned to the AIWS unit when installed in the DECT system.
6. Click **OK**.

Related links

[Enabling Base Station/AIWS Connection](#) on page 186

[Enabling Base Station/AIWS Connection](#) on page 205

Upgrading the AIWS Firmware

About this task

The AIWS is supplied with a default set of firmware. This must be upgraded to the firmware version provided with the IP Office application software. Only the firmware supplied with the IP Office application software or indicated in IP Office Technical Bulletin should be used with AIWS units on IP Office Avaya Wireless DECT systems.

By using a USB memory stick with a Boot software (autoupdate.bin), the module can be upgraded on the field.

Procedure

1. Insert the USB memory stick in the upper USB connector marked 1.
2. Perform a controlled restart via the Restart button, by pressing the button and releasing it within 4 seconds.

The Status LED indicates shutting down with quick flashing blue light. Before starting up again, the Status LED will indicate “waiting” for one minute with flashing yellow light.

3. When the Status LED indicates starting up with quick flashing blue light, press the Mode button within 3 seconds.

The Mode button should indicate boot mode by showing fixed blue light.

Result

The module now detects the memory stick and begins the upgrade process which is indicated by the Status LED with fixed yellow light. The upgrading process takes approximately 7-8 minutes.

After the upgrade process has finished, the module will continue and start up the last used application software. The complete operation may take up to 10 minutes.

To verify a successful upgrade, you can put the USB stick back in your PC and open the file autoupdate.log. In the end of that file, you should see the text “Upgrade finished successfully”.

*** Note:**

If the USB memory stick contains faulty Boot software, the module will start up in Boot Mode.

Related links

[Installing an AIWS2](#) on page 197

[Upgrading the AIWS2 Software](#) on page 208

[Switching Software](#) on page 208

Upgrading the AIWS2 Software

About this task

Ensure that no Device Manager client is open and that no ftp client is logged in to the module.

The information stored in the database will not be overwritten when new software is installed. Files in the netpage folder in the ftp area that are new or changed are kept when updating.

Procedure

1. Click **Configuration** on the start page.
2. Select **Software > Installation** in the menu on the Configuration page.

 **Note:**

Avaya recommends always performing a backup before installing the new software.

3. Select software (.pkg) to upload. The software will replace the non running software.
4. Select **Switch immediately** if you want to run the new software.
5. Select **Copy current settings** if you want the new software to inherit the settings currently used.

This selection will have no effect if the software type is different than the currently used software. The module will always start up using factory settings if the software type differs.

6. Click the **Start Installation** button.

Related links

[Upgrading the AIWS Firmware](#) on page 207

Switching Software

About this task

If two software versions are installed on the module you can switch between them.

Procedure

1. Click **Configuration** on the start page.
2. Select **Software > Switch** in the menu on the Configuration page.
3. Under **Select settings**, select one of the following:
 - Keep previous settings — means that the settings last used for the software is activated again after the switch. This option is only available if the software has been used at least one time before.
 - Copy Current settings — means that you copy the configuration from the software you are currently using and is only available if both software are of the same type.
 - Use factory default settings — means that you apply the default settings that were delivered from the factory.

 **Note:**

The active software current network settings will be kept and will also be applied to the software you want to switch to.

4. Click **Switch**.

Related links

[Upgrading the AIWS Firmware](#) on page 207

Part 10: Non-Provisioned Installation

Chapter 23: Non-Provisioned Installation

This method of installation is used with pre-IP Office Release 7.0 systems and systems that include handsets that do not support IP Office provisioning.

- **When to Use Non-Provisioned Installation**

The use of IP Office [Provisioned Installation](#) on page 60 is recommended for all installations except those that do not contain 3700 Series phones.

- It is assumed that you are familiar with installation and configuration of IP Office systems.

The installation process and screen captures used in this document are for example only. Other methods and order of installed devices can be used once you become familiar with the installation process. For example, installing all of the slave base stations before installing the master base station.

A Non-Provisioned installation consists of the following procedures:

- [Unpacking the DECT Software](#) on page 214
- [Configuring IP DECT Lines](#) on page 216
- [Adding Licenses](#) on page 218
- [Configuring the Master Base Station](#) on page 220
- [Configuring IP Slave Base Stations](#) on page 243
- [Mounting the Base Stations](#) on page 255
- [Subscribing DECT Phones](#) on page 258

Related links

[IP Office Installation Requirements](#) on page 61

[IP Base Station Installation Requirements](#) on page 212

[Phone Subscription Requirements](#) on page 213

[Unpacking the DECT Software](#) on page 214

IP Office Installation Requirements

- It is assumed that you are familiar with installation and configuration of IP Office systems.

Information

- Service user name and password for IP Office configuration access.

- Service user name and password for IP Office security settings access.
- IP Office IP address.
- Avaya IP Endpoint licenses.

Parts

- IP Office software DVD or image of the IP Office admin software.

Tools

- Programming PC with IP Office Manager application installed. You must have administrator rights on this PC to change its IP address settings unless it is functioning as a DHCP client.
- Software for zip file extraction.

Related links

[Provisioned Installation](#) on page 60

[Non-Provisioned Installation](#) on page 211

IP Base Station Installation Requirements

Information

- Avaya Wireless DECT SARI.
- Base Station IP Addresses.
- Detailed plans from the site survey indicating the intended base station locations, LAN sockets and if necessary power supply outlets.

Parts

- Base station

Includes:

- Base station.
- Two 3.5mm screws and two 6mm wall plugs suitable for wall mounting onto a solid wall (brick or similar).
- 1.2 metre (4 foot) LAN cable. If this is replaced with a longer cable the replacement should be a CAT5 Ethernet LAN cable.

Important:

For IP Office Release 10.0 and higher, IPBS1 base stations are only supported as slave radio base stations. IPBS1 base stations are no longer supported in other roles, for example as master base stations. For systems being upgraded, any existing IPBS1 base station being used in a non-slave role must first be replaced in that role with an IPBS2/ IPBS3 or IPBL1.

- If using Power over Ethernet:
 - The base station supports Power over Ethernet, IEEE 802.3af, class 2.

- If not using Power over Ethernet:

- Base station power supply unit.

Required if not using Power over Ethernet to power the base station. Note that the base station power supply units include an 8 metre (26 feet) cable from the PSU to the base station. Check that you have the correct type of power supply unit for the locale.

- BSX-0013: Europe (except United Kingdom).
- BSX-0014: United Kingdom.
- BSX-0015: USA/Canada.
- BSX-0016: Australia.
- Mains power outlet socket.
- LAN Socket.

Tools

- Programming PC with Avaya Wireless DECT software.
- Web browser.
- Drill and drill bits suitable for the selected wall mounting position of the IPBS.
- Screwdrivers for use with the screws selected for IPBS wall mounting.

Related links

[Non-Provisioned Installation](#) on page 211

Phone Subscription Requirements

Information

- Service user name and password for IP Office configuration.
- User names and extension numbers for the DECT phones.
- Phone IPEI numbers if using pre-configured installation mode.

Tools

- **IP Office Manager.**
- **Device Manager**

The software installed on each handset may need to be upgraded to match that supplied with the Avaya Wireless DECT software. This is done using the Windows Device Manager software to upgrade phones via an advanced charger or using AIWS Device Manager to upgrade phones over the air.

- Web browser (Internet Explorer or Firefox are supported).

Related links

[Non-Provisioned Installation](#) on page 211

Unpacking the DECT Software

About this task

Before installing Avaya Wireless DECT, in addition to installing IP Office Manager, unpack the Avaya Wireless DECT software onto your programming PC.

- Avaya Wireless DECT is supported on a range of Avaya systems. For IP Office operation, you must use software specifically documented as tested and supported with IP Office. Details of supported software is included in the IP Office Technical Bulletin for each release.

Procedure

1. On the programming PC, create a folder with a name indicating its purpose, for example `c:\IP_DECT_R4`.
2. Within the IP Office Administrator Application software (that is the software from which IP Office Manager is installed), locate the folder `IPDECT`.
 - The folder contains a file `DECT_R4.zip`. This is the file containing software for Avaya Wireless DECT.
 - The file `IPDECT.zip` contains software for the older IP DECT product and is not used for Avaya Wireless DECT.
3. Copy the `DECT_R4.zip` file to the folder created on the programming PC.
4. Using WinZip or a similar tool, extract the contents of the zip file into the folder, maintaining the directory structure of the zip files.

The set of files should appear similar to the following.

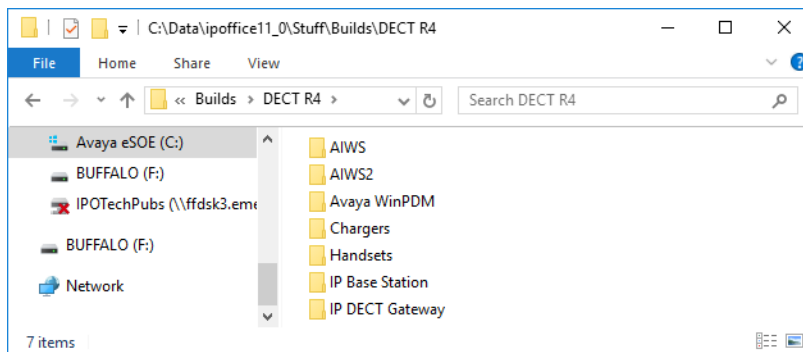

5. Check the software versions as follows:
 - Open the `IP Base Station` folder. There are separate sub-folders for each model of base station. Open each and note the software level shown as part of the `.bin` filenames. There are separate files for the base station boot file and firmware file. All base stations in the installed system must run the same version of software.
 - Open the `Handsets` folder and note the software level shown as part of the `.pkg` filenames. The handsets in the system must be running this level of software or higher.
 - Open the `IP DECT Gateway` folder and note the software level shown as part of the `.bin` filenames. These versions must be of the same level as the IP Base Stations.

Related links

[Non-Provisioned Installation](#) on page 211

Chapter 24: IP DECT Line Setup

About this task

Use the following procedure to create an IP DECT line for traffic between the IP Office and the Avaya Wireless DECT system. The line is configured with the IP address that will be assigned to the master base station. The IP Office configuration only requires a single IP DECT line.

Procedure

1. Using IP Office Manager, retrieve the configuration from the IP Office system.
2. Click on **Line**. The list of existing lines is shown.
3. Click on the  icon and select **IP DECT Line**. The settings for an IP DECT line are displayed. If the option is grayed out then the configuration already contains an IP DECT line.
4. On the **Line** tab there are no adjustable settings. Once the system is installed and operational, this tab lists the DECT extensions.

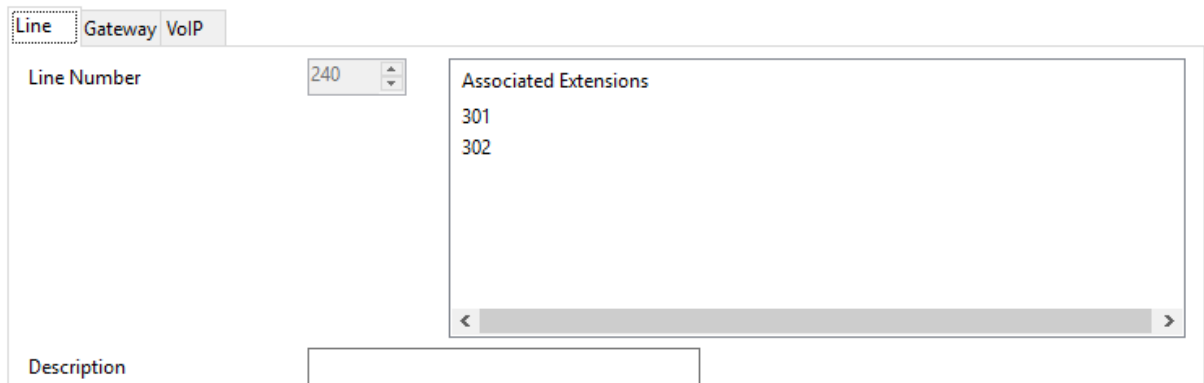

The screenshot shows the configuration interface for a line in IP Office Manager. At the top, there are three tabs: 'Line' (selected), 'Gateway', and 'VoIP'. Below the tabs, there is a 'Line Number' field with a dropdown menu showing '240'. To the right of this field is a list titled 'Associated Extensions' containing the numbers '301' and '302'. Below the list is a horizontal scrollbar. At the bottom left, there is a 'Description' label followed by an empty text input field.

5. Select the **VoIP** tab. This table is used to set details of the master base station.

The screenshot shows a configuration window with three tabs: 'Line', 'Gateway', and 'VoIP'. The 'VoIP' tab is active. The 'Gateway IP Address' field contains '192 . 168 . 0 . 226'. The 'Standby IP Address' field contains '0 . 0 . 0 . 0'. The 'Codec Selection' dropdown is set to 'Custom'. Below this, there are two lists: 'Unused' containing 'G.723.1 6K3 MP-MLQ' and 'Selected' containing 'G.711 ULAW 64K', 'G.711 ALAW 64K', and 'G.729(a) 8K CS-ACELP'. Between the lists are navigation buttons: '>>>', an up arrow, '<<<', a down arrow, and '>>>'. At the bottom, 'TDM->IP Gain' and 'IP->TDM Gain' are both set to 'Default'. On the right side, there are two checkboxes: 'VoIP Silence Suppression' (unchecked) and 'Allow Direct Media Path' (checked).

6. Set the **Gateway IP Address** to match the IP address that will be assigned to the master base station.
7. Leave the **Codec Selection** set to **System Default** if it includes the required codecs, otherwise change the setting to **Custom** and adjust the selected codecs.
 - The 3700 Series phones do not support the OPUS and G.723 codecs.
 - The 3755 and 3759 phones require the G.722 codec to be supported.
8. Select the **Gateway** tab
9. Enter the **SARI/PARK** and **Authentication Code** into the appropriate fields. These values are used during the phone subscription process.

*** Note:**

- To uniquely identify a single system (for example to generate a PARK code), one SARI certificate (Secondary Access Rights Identifier) is required per DECT installation to identify the system.

Related links

[Adding Licenses](#) on page 218

[Reserving Licenses](#) on page 72

Adding Licenses

About this task

For IP Office systems using PLDS licensing, each IP DECT extension requires an **Avaya IP Endpoint** license. This applies even if the handset subscribed to the Avaya Wireless DECT system is not an Avaya phone.

Phones without a license can still subscribe and register but are limited to making emergency calls only (calls that match a **Dial Emergency** short code). The associated user are treated as if logged off . If a license becomes available, it is assigned to any unlicensed DECT handsets first and then to any other unlicensed Avaya IP phone in the order that the phones registered.

- **Avaya IP Endpoint Licenses**

Licenses are added to the IP Office configuration and are based on a serial number unique to the system.

- Licenses are normally automatically assigned to extensions in order of registration. However, existing extensions can be configured to reserve a license. This ensures that they do not become unlicensed when newly added extensions manage to register first following a system reboot.

Related links

[IP DECT Line Setup](#) on page 216

Reserving Licenses

About this task

Licenses are automatically assigned to extensions in order of registration. However existing extensions can reserve a license in order to ensure they do not become unlicensed when new extensions added to the system manage to register first following a system reboot.

Procedure

1. In IP Office Manager, select  **Extension** and then select the DECT extension.

2. Select the **IP DECT** tab. Note, the appearance of this menu will vary depending on whether you are doing a provisioned or non-provisioned installation.

The screenshot shows a configuration window with two tabs: 'Extn' and 'IP DECT'. The 'IP DECT' tab is active. The configuration includes the following fields:

- DECT Line ID:** A dropdown menu showing '240 (190.168.42.224)'.
- Message Waiting Lamp Indication Type:** A dropdown menu showing 'On'.
- IPEI:** A text input field containing '0'.
- Use Handset Configuration:** An unchecked checkbox.
- Reserve Licence:** A dropdown menu showing 'Reserve Avaya IP endpoint licence'.

3. The **Reserve Avaya IP endpoint license** setting is used to reserve an existing license for the extension. The option is greyed out if the configuration does not have sufficient unreserved licenses remaining.
4. Repeat the process for any other extensions for which you want to reserve the license.
5. Save the configuration back to the IP Office system.

Related links

[Adding Licenses](#) on page 72

[IP DECT Line Setup](#) on page 216

Chapter 25: Configuring the Master Base Station

Note:

If an IP DECT Gateway is being installed, Avaya recommends configuring the IP DECT Gateway as the master base station for the system. For information on installing an IP DECT Gateway, see [IP DECT Gateway Installation](#) on page 140.

Related links

[Pre-Requisites](#) on page 221

[Information](#) on page 221

[Parts Required](#) on page 221

[Tools](#) on page 222

[Defaulting the Base Station](#) on page 222

[Accessing the Base Station Configuration](#) on page 223

[Updating the Base Station Firmware](#) on page 224

[Setting the Base Station IP Address](#) on page 227

[Configuring a Virtual Local Area Network \(VLAN\)](#) on page 228

[Setting the Time Source](#) on page 230

[QoS/ToS Settings](#) on page 231

[Setting the Base Station as the Master](#) on page 231

[Enabling Supplementary Services](#) on page 233

[Setting the PBX Switch Mode](#) on page 234

[Configuring IP Trunks](#) on page 235

[Entering the Radio Settings](#) on page 235

[Performing an RFP Scan](#) on page 91

[Entering the PARI](#) on page 237

[Entering the SARI/PARK](#) on page 238

[Configuring Air Sync](#) on page 238

[Integrating the IP Office Directory](#) on page 240

[Resetting a Master Base Station](#) on page 241

[Checking Master Base Station Radio](#) on page 242

Pre-Requisites

- IP Office connected to the LAN with IP DECT line configured for master base station IP address.

Related links

[Configuring the Master Base Station](#) on page 220

Information

- Avaya Wireless DECT SARI.
- Base Station IP Addresses.
- Detailed plans from the site survey indicating the intended base station locations, LAN sockets and if necessary power supply outlets.

Related links

[Configuring the Master Base Station](#) on page 220

[Pre-Requisites](#) on page 243

Parts Required

- Base station

Includes:

- Base station.
- Two 3.5mm screws and two 6mm wall plugs suitable for wall mounting onto a solid wall (brick or similar).
- 1.2 metre (4 foot) LAN cable. If this is replaced with a longer cable the replacement should be a CAT5 Ethernet LAN cable.

Important:

For IP Office Release 10.0 and higher, IPBS1 base stations are only supported as slave radio base stations. IPBS1 base stations are no longer supported in other roles, for example as master base stations. For systems being upgraded, any existing IPBS1 base station being used in a non-slave role must first be replaced in that role with an IPBS2/ IPBS3 or IPBL1.

- If using Power over Ethernet:
 - The base station supports Power over Ethernet, IEEE 802.3af, class 2.
- If not using Power over Ethernet:
 - Base station power supply unit.

Required if not using Power over Ethernet to power the base station. Note that the base station power supply units include an 8 metre (26 feet) cable from the PSU to the base station. Check that you have the correct type of power supply unit for the locale.

- BSX-0013: Europe (except United Kingdom).
- BSX-0014: United Kingdom.
- BSX-0015: USA/Canada.
- BSX-0016: Australia.
- Mains power outlet socket.
- LAN Socket.

Related links

[Configuring the Master Base Station](#) on page 220

[Pre-Requisites](#) on page 243

[Tools](#) on page 222

Tools

- Programming PC with Avaya Wireless DECT software.
- Web browser.
- Drill and drill bits suitable for the selected wall mounting position of the IPBS.
- Screwdrivers for use with the screws selected for IPBS wall mounting.

Related links

[Configuring the Master Base Station](#) on page 220

[Parts Required](#) on page 221

Defaulting the Base Station

About this task

This process will default a base station or IP DECT Gateway, erasing its configuration. After the unit restarts it will default to the IP address 192.168.0.1/255.255.255.0.

Note:

The following instructions assume you are installing an IPBS2/IPBS3, which has one LED lamp. The IPBS1 has two LED lamps. For more information on the base station LEDs and what their statuses indicate, see [Base Station Status Lamps](#) on page 22.

Procedure

1. With only the power supply connected, switch the base station on.

The LED on the base station flashes red if no Ethernet is detected.

2. Wait approximately five seconds.
3. Press and hold the **Reset** button on the base station for approximately 10 seconds..

The LED on the base station will change to a quick flash, then the LED will go out, and then the LED returns to a slower flash.

4. Release the **Reset** button and wait for the base station to reset.

The LED should turn back on to solid amber.

5. Quickly press the **Reset** button once.

The base station reboots with default settings. The default IP is 192.168.0.1, with DHCP on, but not active. If you wish to activate DHCP reset the base station again.

 **Note:**

Avaya recommends disabling the DHCP on the base station and configuring the system with static IP addresses. For information on disabling DHCP on the base station, see [Set the Base Station IP Address](#) on page 78.

Related links

[Configuring the Master Base Station](#) on page 220

Accessing the Base Station Configuration

Procedure

Depending on whether DHCP is being used or not:

- a. Connect the base station to the network or PC using the LAN cable.
- b. If connected directly to the base station, change your programming PC's network address to 192.168.0.200 with subnet mask 255.255.255.0.
- c. If both your PC and the base station are connected to a LAN network with DHCP server, ensure your PC is set to act as a DHCP client or has a fixed address that is valid on the network.
- d. Start your web browser and enter the http:// or https:// followed by the IP address of the base station. The default IP address is 192.168.0.1. If a security certificate warning is displayed, select to continue to this website.
- e. The base station responds with its login menu.

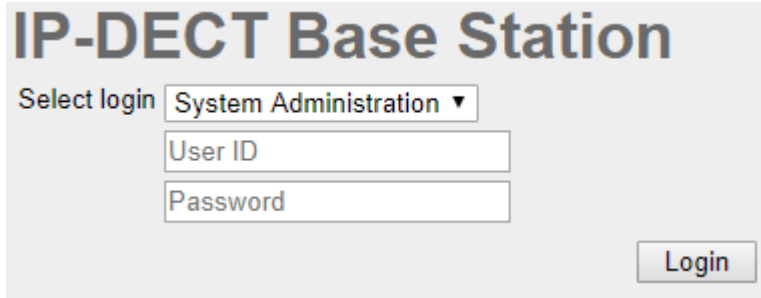

- f. Select **System administration**. Enter the default user name (**admin**) and password (**changeme**) and click **Login**.
- g. A summary of the current logins is displayed. Click **OK**.
- h. The configuration menu for the base station is displayed.

Configuration	Info	Admin	EULA	Logout
General				
LAN				
Administration				
Backup				
Update				
Diagnostics				
Reset				
	Version	IPBS[10.0.5], Bootcode[10.0.5], Hardware[IPBS1-Y4/PD]		
	Serial Number	09AD15300066		
	MAC Address (LAN)	00-01-3e-01-6f-9c		
	DRAM	32 MB		
	FLASH	8 MB		
	Coder	8 Channels of G.711,G.729,G.723		
	SNTP Server	192.168.0.214		
	Time	** ** ** ** **		
	Uptime	0d 1h 38m 42s		

- i. Note the software levels shown in the **General | Info** menu. These will determine if the base station software needs to be upgraded.

*** Note:**

Compact Base Stations have advanced menu options hidden by default. To enable or disable Advanced Administration menus, see [Select Administration Mode](#) on page 83 .

Related links

[Configuring the Master Base Station](#) on page 220

Updating the Base Station Firmware

About this task

The base station may need to be upgraded to match the software version supplied for use with the IP Office. The base station software consists of two parts, a firmware file and a boot file. All base stations in a DECT system should use the same version of software.

Procedure

1. Browse into the base station configuration and note the software levels shown by the **Version** line.

Configuration	Info	Admin	EULA	Logout
General				
LAN				
Administration	Version IPBS[10.0.5], Bootcode[10.0.5], Hardware[IPBS1-Y4/PD] Serial Number 09AD15300066 MAC Address (LAN) 00-01-3e-01-6f-9c DRAM 32 MB FLASH 8 MB Coder 8 Channels of G.711,G.729,G.723 Sntp Server 192.168.0.214 Time ** ** ** ** Uptime 0d 1h 38m 42s			
Backup				
Update				
Diagnostics				
Reset				

2. Check that these match the versions supplied with the IP Office administration software.

Ensure that you are checking against the correct folder for an IPBS1, IPBS2 or IPBS3 base station. If they do not match, you must upgrade the base station.

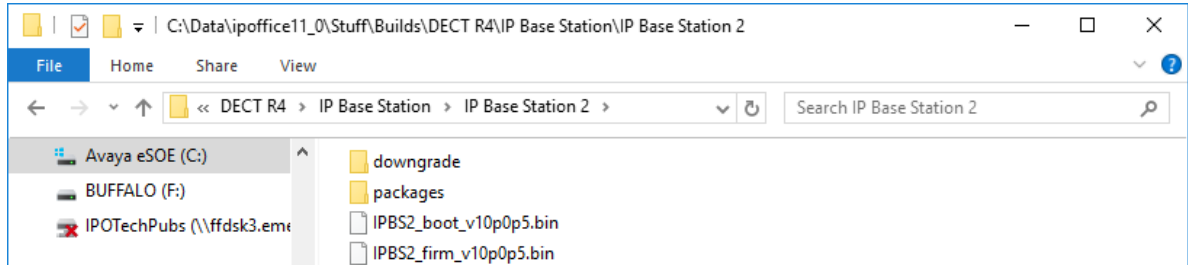

If both software files need to be upgraded, the boot file should be upgraded first.

3. In the left-hand column, under the **Administration** menu, select **Update** and then select the **Boot** tab.

Configuration	Config	Firmware	Boot	Logout
General				
LAN				
Administration	<h3>Upload bootcode to flash</h3> <p>Flash status: Bootcode Checksum OK Firmware Checksum OK Do not interrupt bootcode upload! This may leave the bootcode defect. If for some reason the bootcode upload was interrupted, repeat the upload before reboot.</p> <p>Bootcode File: <input type="button" value="Choose File"/> No file chosen</p> <p><input type="button" value="Upload"/></p>			
Backup				
Update				
Diagnostics				
Reset				

4. Click on the **Browse** button and browse to the **IP Base Station** sub-folder of the Avaya Wireless DECT software.
5. Select the appropriate boot file for the upgrade you are performing.
6. Click **OK**.
7. Click on the **Upload** button.

The browser shows the progress of the upload and upgrade. It will indicate when the process has been completed.



8. If necessary, repeat the process to upgrade remaining base stations.
9. To upgrade the base station firmware file, select **Update** and then select the **Firmware** tab.

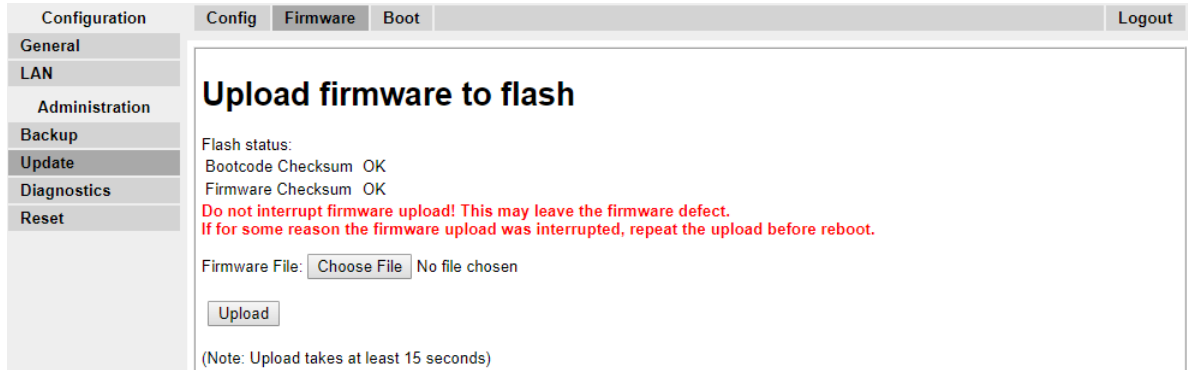

10. Click on the **Browse** button and browse to the **IP Base Station** sub-folder of the Avaya Wireless DECT software you previously extracted onto the programming PC.
11. Select the appropriate firmware file for the upgrade you are performing,
12. Click **OK**.
13. Click on the **Upload** button.

The browser shows the progress of the upload and upgrade. It will indicate when the process has been completed.

14. Click on **Reset**.
15. Log in again. The **General > Info** tab should now list the new firmware.

If necessary:

- Repeat the process for the remaining base stations using the **Update > Firmware** menu.
- Update the base station firmware for base stations that will connect to an IP DECT Gateway using the **Update > RFPs** menu.

Related links

[Configuring the Master Base Station](#) on page 220

Setting the Base Station IP Address

About this task

During initial installation the IP address of a base station defaults to 192.168.0.1. The process below can be used to change the DHCP mode and IP address of a base station.

Procedure

1. From the base station configuration window, in the left-hand column, select **LAN**.
2. Select the **IP** tab.

Configuration	DHCP	IP	802.1X	LLDP	Logout
General					
LAN					
Administration					
Backup					
Update					
Diagnostics					
Reset					

Active Settings

IP Address: 192.168.0.226

Network Mask: 255.255.255.0

Default Gateway: 192.168.0.1

DNS Server:

Alt. DNS Server:

Check ARP:

- a. Enter the required **IP Address** and **Network Mask** for the base station. The other settings are optional.
- b. Click **OK**.

*** Note:**

The menu will prompt you with the message **Reset Required**. Do not click this or reset the base station at this stage.

- c. Select the **DHCP** tab.

Configuration	DHCP	IP	802.1X	LLDP	Logout
General					
LAN					
Administration					
Backup					

Mode: Currently - disabled

- d. Using the **Mode** drop-down, select **Disabled**.
- e. Click **OK**.
- f. Select **Reset** and then select the **Reset** tab.
- g. Click **OK**.
- h. Depending on your base station, wait for the LED to return to solid blue or solid green.
- i. Log in again using the new IP address.

Related links

[Configuring the Master Base Station](#) on page 220

Configuring a Virtual Local Area Network (VLAN)

Both IPBS1 and IPBS2/IPBS3 support VLAN capability. Note that the VLAN ID must be the same as the ID configured in the IPBS/IPBL, otherwise access to the IPBS/IPBL will not be possible.

*** Note:**

If "VLAN = 0", the Quality of Service (QoS) is inactive according to 802.1q. You should also avoid "VLAN = 1" as it is often used as a default VLAN setting.

Related links

[Configuring the Master Base Station](#) on page 220

[Configuring a VLAN](#) on page 79

Configuring a VLAN

About this task

Use the following procedure to configure a VLAN ID on a systems comprised of switches and endpoints that support VLAN tagging (IEEE 802.1q).

Procedure

1. Under the **Configuration** menu, navigate to **LAN** and then select the **VLAN** tab.

Configuration | DHCP | IP | **VLAN** | Link | 802.1X | Statistics | LLDAP | Logout

General
LAN
 Administration
 Backup
 Update
 Diagnostics
 Reset

Configure the VLAN ID only if the switches and endpoints support VLAN tagging (IEEE 802.1q). For priority tagging (802.1p) it is sufficient to configure the RTP priority value only. Please be aware that you may not be able to access the device any further if the VLAN ID is changed!

Active Settings

ID
 Priority - RTP Data
 Priority - Signalling

OK Cancel

2. In the **ID** field, enter the parameter configured in the IPBS/IPBL.
3. Click **OK**.

Related links

[Configuring a Virtual Local Area Network \(VLAN\)](#) on page 79

[Viewing LAN Statistics](#) on page 80

[Deactivating LAN Port \(IPBL only\)](#) on page 80

[Configuring a Virtual Local Area Network \(VLAN\)](#) on page 228

[Viewing LAN Statistics](#) on page 80

[Deactivating LAN Port \(IPBL only\)](#) on page 80

Viewing LAN Statistics

About this task

To view statistics of LAN events.

Procedure

1. On a IPBS, select **LAN > Statistics**. On a IPBL, select **LAN1 > Statistics**.

Configuration	DHCP	IP	VLAN	Link	802.1X	Statistics	LLDP	Logout
General								
LAN								
Administration								
Backup								
Update								
Diagnostics								
Reset								

tx-good
tx-unicast
tx-broadcast
tx-multicast
tx-lostcarrier
tx-deferred
tx-collision
tx-excesscol

2. Press `Clear` to reset the Ethernet statistics counters. You may need to scroll down to view the **Clear** button.

Related links

[Configuring a VLAN](#) on page 79

[Configuring a VLAN](#) on page 79

Deactivating LAN Port (IPBL only)

About this task

The IP DECT Gateway (IPBL) has two LAN ports. The LAN2 port is used for administration only. If necessary, you can deactivate that port.

Procedure

1. Select **LAN2 > IP**.

Note: The LAN2 port is for administration only. It is typically the port you want to deactivate.

Configuration	System	Suppl. Serv.	Master	Trunks	Radio	Radio config	PARI	SARI	Air Sync	Logout
General										
LAN										
IP										
LDAP										
DECT										
VoIP										
Unite										
Services										
Administration										
Users										
Device Overview										
DECT Sync										
Traffic										

Active Settings

IP Address 192.168.1.1

Network Mask 255.255.255.0

Default Gateway 172.29.40.254

DNS Server

Alt. DNS Server

Check ARP

Disable

No IP protocol data will be sent/received via this interface

2. Select the **Disable** checkbox.
3. Click **OK**.

Related links

- [Configuring a VLAN](#) on page 79
- [Configuring a VLAN](#) on page 79

Setting the Time Source

About this task

The base station can obtain its time from the IP Office control unit.

Procedure

1. In the left-hand column select **General**. Select the **NTP** tab.

Configuration	Info	Admin	NTP	Kerberos Server	Certificates	EULA	Logout
General							
LAN							
IP							
LDAP							
DECT							
VoIP							
Unite							
Services							
Administration							
Users							
Device Overview							

Active Settings

Time Server

Alt. Time Server

Interval [min] 60

Timezone ▾

String CET-1CEST-2,M3.5.0/2,M10.5.0/3

Current Server

Last Sync 26.10.2017 14:20

2. In the **Time Server** field enter the IP address of the IP Office.
3. Click **OK**.

Related links

[Configuring the Master Base Station](#) on page 220

QoS/ToS Settings

About this task

If the network uses QoS/ToS for VoIP traffic, the base station should be configured to use the same settings.

Procedure

1. In the browser connection to the base station, in the left-hand panel select **IP**. Select the **Settings** tab.

Configuration		Settings	Routing	TLS	Logout
General					
LAN					
IP					
LDAP					
DECT					
VoIP					
Unite					
Services					
Administration					
Users					
Device Overview					
DECT Sync					

Priority/DiffServ

ToS Priority - RTP Data **Active Settings**

ToS Priority - VoIP Signalling **Active Settings**

Port Ranges

First UDP-RTP Port **Active Settings**

Number of Ports

Last UDP-RTP Port **Active Settings**

2. Set the **ToS Priority - RTP Data** value to match the IP Office's **DSCP (Hex)** value.
3. Set the **ToS Priority - VoIP Signalling** value to match the IP Office's **SIG DSCP (Hex)** value.
4. Click **OK**.

Related links

[Configuring the Master Base Station](#) on page 220

Setting the Base Station as the Master

About this task

A number of menus are disabled until the base station has been set as the master base station for the IP Office Avaya Wireless DECT system.

Procedure

1. In the left-hand panel select **DECT**, and then select the **Master** tab.

The screenshot shows the configuration interface with the 'DECT' tab selected in the left-hand panel and the 'Master' tab selected in the top navigation bar. The 'Mode' dropdown menu is set to 'Off'. There are 'OK' and 'Cancel' buttons at the bottom of the configuration area.

2. Use the **Mode** drop-down box to select **Active**, and click **OK**.
3. Click on the **Reset required!** message.

The screenshot shows the configuration interface with 'Mode' set to 'Active'. A message below the dropdown reads: "No Admin password. Configure Admin password on DECT/System page." Below this message is a red text alert that says "Reset required!". There are 'OK' and 'Cancel' buttons.

4. Click **OK**.

The screenshot shows a confirmation dialog box with the text: "Reset only if the system is idle (no active calls, etc.)". There is an 'OK' button.

5. In the left-hand panel select **DECT**. Select the **System** tab.

The screenshot shows the 'System' configuration page for DECT. The left-hand panel has 'DECT' selected, and the top navigation bar has 'System' selected. The configuration fields are as follows:

- System Name: DECT
- Password: [masked]
- Confirm Password: [masked]
- Subscriptions: With System AC
- Authentication Code: 1234
- Default Language: English
- Frequency: Europe
- Enabled Carriers: 0 1 2 3 4 5 6 7 8 9 (all checked)
- Coder: G729A, Frame (ms): 60, Exclusive SC

There are 'OK' and 'Cancel' buttons at the bottom.

6. Set and check the following values:

- **System Name**

Enter name to identify the DECT system. This must be a unique name if there are other DECT systems in the same area.

- **Password**

Enter the same password as being used for admin access to the base stations. The default is **changeme**. Re-enter the password in the **Confirm Password** field.

- **Subscriptions**

Select **With System AC**. This allows phones to be subscribed to the system using the system authentication code as set below.

- **Authentication Code**

This code is required by phones during subscription to the DECT system.

- **Default Language**

Select the language required by the customer.

- **Frequency**

You must ensure that the correct region is selected. This affects the frequency used for DECT wireless signalling and other factors.

- Do not adjust the **Coder** options.
- Click **OK**.

Related links

[Configuring the Master Base Station](#) on page 220

Enabling Supplementary Services

About this task

Enabling supplementary services is required for IP Office operation.

Procedure

1. In the left-hand panel select **DECT**, and then select the **Suppl. Serv.** tab.

The screenshot shows the configuration interface for the DECT system. The left-hand panel has 'DECT' selected under the 'Services' category. The main window displays the 'Supplementary Services' configuration page. The 'Suppl. Serv.' tab is active, and the 'Enable Supplementary Services' checkbox is checked. Below this, there are fields for 'Logout User' (set to '#11*\$#') and a 'Disable' button. The 'Voice Mail' section shows the 'Fix Message Center No.' set to '*17'. At the bottom, there are 'OK' and 'Cancel' buttons.

2. Select **Enable Supplementary Services**.
3. In the **Fix Message Center No.** field enter *17. This is the IP Office default short code for voicemail access. If the IP Office has been configured to use a different short code enter that short code.
4. Click **OK**.

Related links

[Configuring the Master Base Station](#) on page 220

Setting the PBX Switch Mode

About this task

The master base station needs to be configured for the type of PBX and the protocol to use for communication with the PBX.

Procedure

1. In the left-hand panel select **DECT**, and then select the **Master** tab.

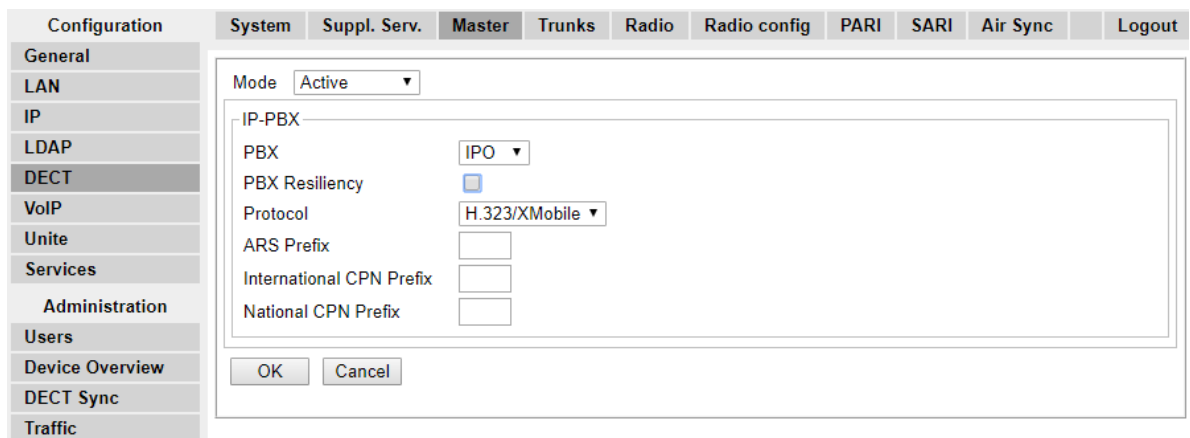

2. Using the **PBX** drop-down list, select **IPO**.
3. Check that the **Protocol** is set to **H.323/XMobile**.
4. Click **OK**.
 - The message **Reset required!** is displayed. At this stage further changes are required so do **not** reset the base station.

Related links

[Configuring the Master Base Station](#) on page 220

Configuring IP Trunks

About this task

An IP trunk to the IP Office must be configured. Only one trunk is supported.

Procedure

1. In the left-hand panel select **DECT**, and then select the **Trunks** tab.

Configuration																				
System	Suppl. Serv.	Master	Trunks	Radio	Radio config	PARI	SARI	Air Sync	Logout											
General						Trunk List Primary Trunks <table border="1"> <thead> <tr> <th>Name</th> <th>Local Port</th> <th>CS IP Address</th> <th>CS Port</th> <th>Status</th> </tr> </thead> <tbody> <tr> <td>Trunk1</td> <td>1720</td> <td>192.168.0.210</td> <td>1720</td> <td>Active</td> </tr> </tbody> </table>					Name	Local Port	CS IP Address	CS Port	Status	Trunk1	1720	192.168.0.210	1720	Active
Name	Local Port	CS IP Address	CS Port	Status																
Trunk1	1720	192.168.0.210	1720	Active																
LAN																				
IP																				
LDAP																				
DECT																				
VoIP																				
Unite																				
Services																				
OK						Cancel														

2. Enter the following settings:

- **Name:** Set a name that identifies the IP Office system.
- **Local Port:** Set this to **1720**.
- **CS IP Address:** Set this field to the IP address of the IP Office system.
- **CS Port :** Set this to **1720**.

3. Click **OK**.

- The message **Reset required!** is displayed. At this stage further changes are required so do **not** reset the base station.

Related links

[Configuring the Master Base Station](#) on page 220

Entering the Radio Settings

About this task

Having been configured as the master base station, the radio aspect of the base station can be configured. Note that IP Office does not support use of a standby master base station.

Procedure

1. In the left-hand panel select **DECT**. Select the **Radio** tab.

The screenshot shows the configuration interface for a DECT system. The left-hand navigation menu is expanded to show the 'DECT' section, which includes sub-items like 'General', 'LAN', 'IP', 'LDAP', 'DECT', 'VoIP', 'Unite', 'Services', 'Administration', 'Users', 'Device Overview', 'DECT Sync', 'Traffic', 'Backup', and 'Update'. The 'DECT' sub-item is selected. The main configuration area is titled 'Radio' and contains the following elements:

- A 'Disable' checkbox, which is currently unchecked.
- A 'Master' section with the following fields:
 - Name:** DECT
 - Password:** Masked with 10 dots
 - Master IP Address:** 127.0.0.1
 - Standby Master IP Address:** (Empty field)
 - Status:** No Connection to Master
- An 'Uninitialized Master Connections' table:

IP Address	State
192.168.42.210	Up
- 'OK' and 'Cancel' buttons.
- A red message: **Reset required!**

2. Set the following values:

- **Name**

Set this to match the **System Name** set on the **DECT | System** tab.

- **Password**

Set this to match the **Password** set on the **DECT | System** tab.

- **Master IP Address**

Set the address 127.0.0.1 for the base station to refer to itself. (Alternatively set this to match the IP address assigned to the base station on the **LAN | IP** tab).

- Click **OK**.

- The message **Reset required!** is displayed. At this stage further changes are required so do **not** reset the base station.

Related links

[Configuring the Master Base Station](#) on page 220

Performing an RFP Scan

About this task

The following processes are only required if the DECT system is operating in the same area as other DECT systems.

The Primary Access Rights Identifier (PARI) is a part of the IPBS broadcast identity, which uniquely identifies each DECT system. This PARI is automatically assigned to each master in

the system. However, if more than one DECT system operates within the same coverage area, each system need to have a unique PARI assigned in order to differentiate the systems.

To see the occupied system IDs of other Avaya IP-DECT systems within the coverage area, perform an RFP scan using the following procedure:

Procedure

1. Select **Diagnostics**
2. Select **RFP Scan**
3. Click **Start Scanning**

*** Note:**

Executing an RFP scan will terminate all calls on the IPBS.

Related links

[Master Base Station Setup](#) on page 75

[Configuring the Master Base Station](#) on page 220

Entering the PARI

About this task

A Primary Access Rights Identifier (PARI) is required to identify the master base station for the Avaya Wireless DECT system. Use the following procedure to configure the PARI on the master base station.

Procedure

1. In the left-hand panel select **DECT**. Select the **PARI** tab.

The screenshot shows a configuration window with a left-hand navigation pane and a main content area. The navigation pane has tabs for Configuration, General, LAN, IP, LDAP, and DECT. The DECT tab is selected. The main content area has tabs for System, Suppl. Serv., Master, Trunks, Radio, Radio config, PARI, SARI, Air Sync, and Logout. The PARI tab is selected. In the main content area, there is a text input field labeled 'System ID' containing the number '30'. Below the input field are two buttons: 'OK' and 'Cancel'.

2. Enter a value between 1 and 35. This value must be unique from any other Avaya Wireless DECT master base station in the area.
3. Click **OK**.

Related links

[Configuring the Master Base Station](#) on page 220

Entering the SARI/PARK

About this task

The SARI is the license for the Avaya Wireless DECT system.

Procedure

1. In the left-hand panel, select **DECT**. Select the **SARI** tab.

The screenshot shows a configuration window with a left-hand navigation pane and a main content area. The navigation pane has a 'Configuration' header and several sub-sections: General, LAN, IP, LDAP, DECT, and VoIP. The 'DECT' section is expanded, showing tabs for System, Suppl. Serv., Master, Trunks, Radio, Radio config, PARI, SARI, Air Sync, and Logout. The 'SARI' tab is selected. In the main content area, the word 'SARI' is displayed above a text input field containing the number '31100243777703'. Below the input field are two buttons: 'OK' and 'Cancel'.

2. Enter the SARI code provided with the Avaya Wireless DECT equipment.
3. Click **OK**.

Related links

[Configuring the Master Base Station](#) on page 220

Configuring Air Sync

About this task

Base stations in the Avaya Wireless DECT system need to be synchronized with each other. This can be done with a signal as low as -90dB between base stations.

One base station is assigned as the 'air sync master', typically the master base station. Each other base station can sync directly with it or indirectly via a synchronization chain. However, it is preferable that the number of synchronization 'hops' between any particular base station and its air sync master base station is kept as low as possible. To help achieve this it is recommended that the air sync master is placed centrally within the set of base stations.

Where possible, each base station should be placed within synchronization range of more than one base station, which allows the base stations to maintain synchronization should one base station fail or be switched off for maintenance. The process of synchronizing by the shortest route to the air sync master when in synchronization range of multiple base stations is automatic.

Procedure

1. In the left-hand panel, select **DECT**. Select the **Air Sync** tab.

The screenshot shows the configuration interface for the Air Sync tab. The left-hand panel has a navigation menu with 'DECT' selected. The main area shows the 'Air Sync' configuration form with the following fields and options:

- Sync Mode: Master (dropdown menu)
- Reference RFPI: (text input field)
- Alternative reference RFPI: (text input field)
- Sync Region: 0 (text input field)
- Action at reference sync failure:
 - Resynchronize on command
 - Resynchronize every day at 00:00 (dropdown menu)
 - Resynchronize every Sunday at 00:00 (dropdown menu)

OK and Cancel buttons are located at the bottom of the form.

2. Set the **Sync Mode** to **Master**.
3. Click **OK**.

Related links

- [Configuring the Master Base Station](#) on page 220
- [Advanced Scenario: Separated Locations](#) on page 56

Advanced Scenario: Separated Locations

In most scenarios, the master base station (Standard or Compact) is also used as the air sync master for all the other slave base stations and that is the scenario documented in this manual. However, in scenarios where you have base stations in separate locations that are not within synchronization range of each other, it is permissible to assign separate air sync masters in each location. However, there must be absolutely no overlap (<-90dB) between the separate groups of base stations. Any overlap will cause frequent loss of synchronization.

Having separate locations, each with its own synchronization, is done through the settings on the **DECT | Air Sync** tab of each base station. For each location, set the same **Sync Region** number for all the base stations at that location, using a different number for each location. In addition, use the **Sync Mode** drop-down menu to configure one of the base stations in each location as the **Master** base station.

* Note:

In deployments in mixed systems with IP Base Stations and IP-DECT Gateways, the IP-DECT Gateways need to be physically interconnected for the purpose of radio synchronization. When configuring an IP-DECT Gateway as an air sync master, use sync region 0. All other base stations should be configured as sync slaves. Systems with IPBS in sync regions that have only IPBS should use non-zero sync region number(s) and be configured with at least one sync master with the remaining IPBSs configured as sync slaves.

Related links

- [Site Survey and Planning](#) on page 52
- [Master Base Station Setup](#) on page 75

[Configuring Air Sync in Separated Locations](#) on page 94

[Configuring Air Sync](#) on page 238

[Configuring Air Sync in Separated Locations](#) on page 94

Configuring Air Sync in Separated Locations Procedure

1. For each base station in the system, configure a **Sync Region** number under the **DECT | Air Sync** tab in the Device Manager and click **OK**.

All the base stations in a single region should contain the same **Sync Region** number, but each Sync Region must have its own unique number. By default, **Sync Region = 0**, which means that no region is defined.

2. For each new Sync Region created, configure one base station as the **Master** using the **Sync Mode** drop-down menu and click **OK**.

You must configure at least one master base station per region.

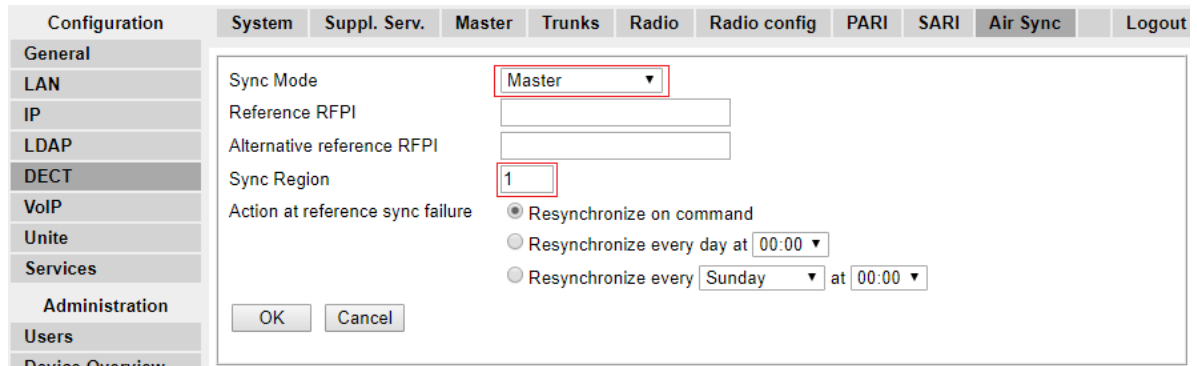

Related links

[Advanced Scenario: Separated Locations](#) on page 56

[Advanced Scenario: Separated Locations](#) on page 56

Integrating the IP Office Directory

About this task

With IP Office Release 6 and later, the master base station can obtain directory information direct from the IP Office control unit rather than the system requiring an AIWS unit to do this. This requires the master base station to be able to access the IP Office control unit using TFTP. The directory import is limited to 6000 entries.

Note that enabling directory integration via the master base station disables support for SMS. If both SMS and directory integration are required then an AIWS unit must be used.

Procedure

1. In the left-hand panel, select **Phonebook**.

2. Select **Enable**.
3. Select the other settings as shown above, with the **Server IP Address** set to the IP address of the IP Office control unit.
4. Click on **OK**.

Related links

[Configuring the Master Base Station](#) on page 220

Resetting a Master Base Station

About this task

Having completed the configuration changes, the master base station should be reset.

Procedure

1. In the left-hand panel, select **Reset**. Select the **Reset** tab or **Idle-Reset** tab.

2. Click **OK**.

Related links

[Configuring the Master Base Station](#) on page 220

Checking Master Base Station Radio

About this task

Following the reset, the operation of the radio part can be checked.

Procedure

1. In the left-hand panel, select **DECT**. Select the **Radio** tab.

The screenshot shows the Avaya Wireless DECT configuration interface. The left-hand panel has a tree view with the following categories and sub-items:

- Configuration
 - General
 - LAN
 - IP
 - LDAP
 - DECT** (selected)
 - VoIP
 - Unite
 - Services
- Administration
 - Users
 - Device Overview
 - DECT Sync
 - Traffic
 - Backup
 - Update
 - Diagnostics
 - Reset

The top navigation bar includes tabs for System, Suppl. Serv., Master, Trunks, **Radio**, Radio config, PARI, SARI, Air Sync, and Logout.

The main configuration area is titled "Radio" and contains the following sections:

- Disable**
- Master**
 - Name: IPBS2
 - Password: masked
 - Master IP Address: 192.168.0.227
 - Alt. Master IP Address: 192.168.0.226
 - Status: Connected to Master 192.168.0.227
- Max RTP Streams**
 - Number of Streams: []
- Received Configuration**
 - SARI: 31100243777703
 - RFPI: 9014AC1008
 - Subscriptions: Disable
 - Authentication Code: []
 - Default Language: English
 - Frequency: 1920-1930 MHz (North America)
 - Enabled Carriers: 23 24 25 26 27 (all checked)
 - Early Encryption: disabled
 - ICE: enabled
 - Coder: 20 ms
 - Secure RTP Key Exchange: No encryption

Buttons for "OK" and "Cancel" are located at the bottom of the configuration area.

2. The **Status** should indicate **Connected to Master**.
3. The **Received Configuration** settings should match the parameters entered during configuration.

Related links

[Configuring the Master Base Station](#) on page 220

Chapter 26: Configuring IP Slave Base Stations

The base station installation process consists of the following stages.

Related links

- [Pre-Requisites](#) on page 243
- [Defaulting the Base Station](#) on page 245
- [Accessing Base Station Configuration](#) on page 246
- [Updating Base Station Firmware](#) on page 247
- [Setting a Base Station IP Address](#) on page 249
- [Setting a Base Station to Slave Mode](#) on page 250
- [Resetting a Base Station](#) on page 252

Pre-Requisites

- IP Office connected to the LAN with IP DECT line configured for master base station IP address.

Related links

- [Configuring IP Slave Base Stations](#) on page 243
- [Information](#) on page 221
- [Parts Required](#) on page 221

Information

- Avaya Wireless DECT SARI.
- Base Station IP Addresses.
- Detailed plans from the site survey indicating the intended base station locations, LAN sockets and if necessary power supply outlets.

Related links

- [Configuring the Master Base Station](#) on page 220
- [Pre-Requisites](#) on page 243

Parts Required

- Base station

Includes:

- Base station.
- Two 3.5mm screws and two 6mm wall plugs suitable for wall mounting onto a solid wall (brick or similar).
- 1.2 metre (4 foot) LAN cable. If this is replaced with a longer cable the replacement should be a CAT5 Ethernet LAN cable.

Important:

For IP Office Release 10.0 and higher, IPBS1 base stations are only supported as slave radio base stations. IPBS1 base stations are no longer supported in other roles, for example as master base stations. For systems being upgraded, any existing IPBS1 base station being used in a non-slave role must first be replaced in that role with an IPBS2/ IPBS3 or IPBL1.

- If using Power over Ethernet:
 - The base station supports Power over Ethernet, IEEE 802.3af, class 2.
- If not using Power over Ethernet:
 - Base station power supply unit.

Required if not using Power over Ethernet to power the base station. Note that the base station power supply units include an 8 metre (26 feet) cable from the PSU to the base station. Check that you have the correct type of power supply unit for the locale.

- BSX-0013: Europe (except United Kingdom).
- BSX-0014: United Kingdom.
- BSX-0015: USA/Canada.
- BSX-0016: Australia.
- Mains power outlet socket.
- LAN Socket.

Related links

[Configuring the Master Base Station](#) on page 220

[Pre-Requisites](#) on page 243

[Tools](#) on page 222

Tools

- Programming PC with Avaya Wireless DECT software.
- Web browser.
- Drill and drill bits suitable for the selected wall mounting position of the IPBS.
- Screwdrivers for use with the screws selected for IPBS wall mounting.

Related links

[Configuring the Master Base Station](#) on page 220

[Parts Required](#) on page 221

Defaulting the Base Station

About this task

This process will default a base station or IP DECT Gateway, erasing its configuration. After the unit restarts it will default to the IP address 192.168.0.1/255.255.255.0.

*** Note:**

The following instructions assume you are installing an IPBS2/IPBS3, which has one LED lamp. The IPBS1 has two LED lamps. For more information on the base station LEDs and what their statuses indicate, see [Base Station Status Lamps](#) on page 22.

Procedure

1. With only the power supply connected, switch the base station on.

The LED on the base station flashes red if no Ethernet is detected.

2. Wait approximately five seconds.

3. Press and hold the **Reset** button on the base station for approximately 10 seconds..

The LED on the base station will change to a quick flash, then the LED will go out, and then the LED returns to a slower flash.

4. Release the **Reset** button and wait for the base station to reset.

The LED should turn back on to solid amber.

5. Quickly press the **Reset** button once.

The base station reboots with default settings. The default IP is 192.168.0.1, with DHCP on, but not active. If you wish to activate DHCP reset the base station again.

*** Note:**

Avaya recommends disabling the DHCP on the base station and configuring the system with static IP addresses. For information on disabling DHCP on the base station, see [Set the Base Station IP Address](#) on page 78.

Related links

[Configuring IP Slave Base Stations](#) on page 243

Accessing Base Station Configuration

Procedure

Depending on whether DHCP is being used or not:

- a. Connect the base station to the network or PC using the LAN cable.
- b. If connected directly to the base station, change your programming PC's network address to 192.168.0.200 with subnet mask 255.255.255.0.
- c. If both your PC and the base station are connected to a LAN network with DHCP server, ensure your PC is set to act as a DHCP client or has a fixed address that is valid on the network.
- d. Start your web browser and enter the http:// or https:// followed by the IP address of the base station. The default IP address is 192.168.0.1. If a security certificate warning is displayed, select to continue to this website.
- e. The base station responds with its login menu.

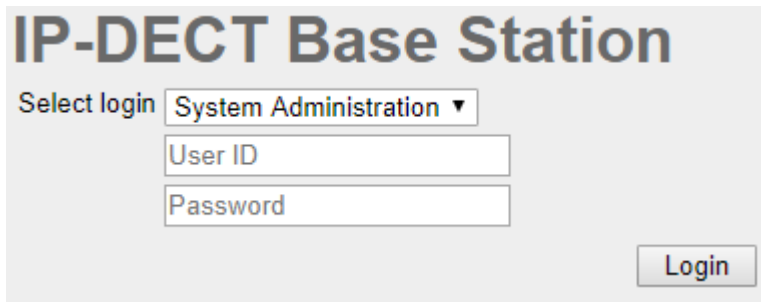

- f. Select **System administration**. Enter the default user name (**admin**) and password (**changeme**) and click **Login**.
- g. A summary of the current logins is displayed. Click **OK**.
- h. The configuration menu for the base station is displayed.

Configuration	Info	Admin	EULA	Logout
General				
LAN	Version IPBS[10.0.5], Bootcode[10.0.5], Hardware[IPBS1-Y4/PD]			
Administration	Serial Number 09AD15300066			
Backup	MAC Address (LAN) 00-01-3e-01-6f-9c			
Update	DRAM 32 MB			
Diagnostics	FLASH 8 MB			
Reset	Coder 8 Channels of G.711,G.729,G.723			
	SNTP Server 192.168.0.214			
	Time ** ** ** **			
	Uptime 0d 1h 38m 42s			

- i. Note the software levels shown in the **General | Info** menu. These will determine if the base station software needs to be upgraded.

*** Note:**

Compact Base Stations have advanced menu options hidden by default. To enable or disable Advanced Administration menus, see [Select Administration Mode](#) on page 83 .

Related links

[Configuring IP Slave Base Stations](#) on page 243

Updating Base Station Firmware

About this task

The base station may need to be upgraded to match the software version supplied for use with the IP Office. The base station software consists of two parts, a firmware file and a boot file. All base stations in a DECT system should use the same version of software.

Procedure

1. Browse into the base station configuration and note the software levels shown by the **Version** line.

Configuration	Info	Admin	EULA	Logout
General				
LAN	Version IPBS[10.0.5], Bootcode[10.0.5], Hardware[IPBS1-Y4/PD]			
Administration	Serial Number 09AD15300066			
Backup	MAC Address (LAN) 00-01-3e-01-6f-9c			
Update	DRAM 32 MB			
Diagnostics	FLASH 8 MB			
Reset	Coder 8 Channels of G.711,G.729,G.723			
	SNTP Server 192.168.0.214			
	Time ** ** ** **			
	Uptime 0d 1h 38m 42s			

2. Check that these match the versions supplied with the IP Office administration software.

Ensure that you are checking against the correct folder for an IPBS1, IPBS2 or IPBS3 base station. If they do not match, you must upgrade the base station.

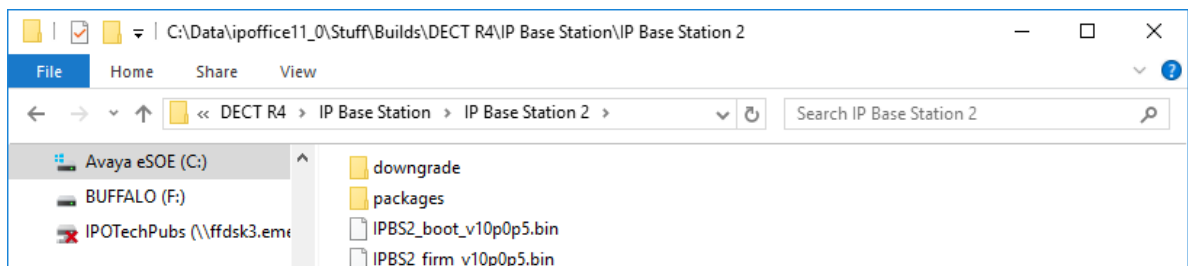

If both software files need to be upgraded, the boot file should be upgraded first.

- In the left-hand column, under the **Administration** menu, select **Update** and then select the **Boot** tab.

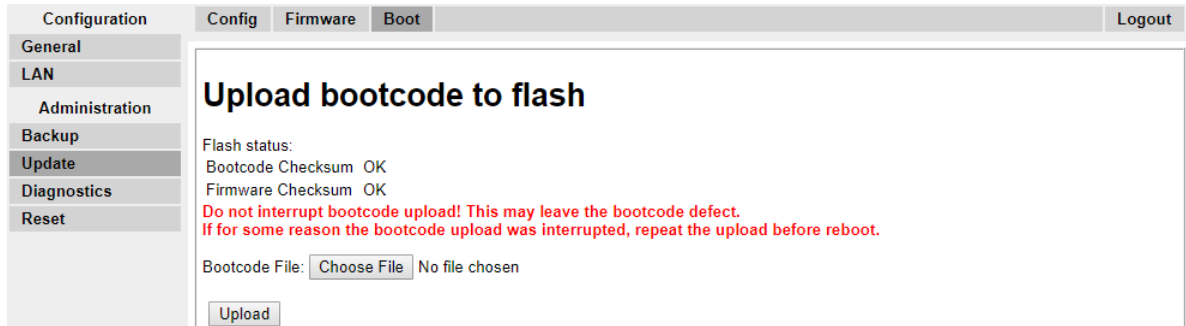

- Click on the **Browse** button and browse to the **IP Base Station** sub-folder of the Avaya Wireless DECT software.
- Select the appropriate boot file for the upgrade you are performing.
- Click **OK**.
- Click on the **Upload** button.

The browser shows the progress of the upload and upgrade. It will indicate when the process has been completed.



- If necessary, repeat the process to upgrade remaining base stations.
- To upgrade the base station firmware file, select **Update** and then select the **Firmware** tab.

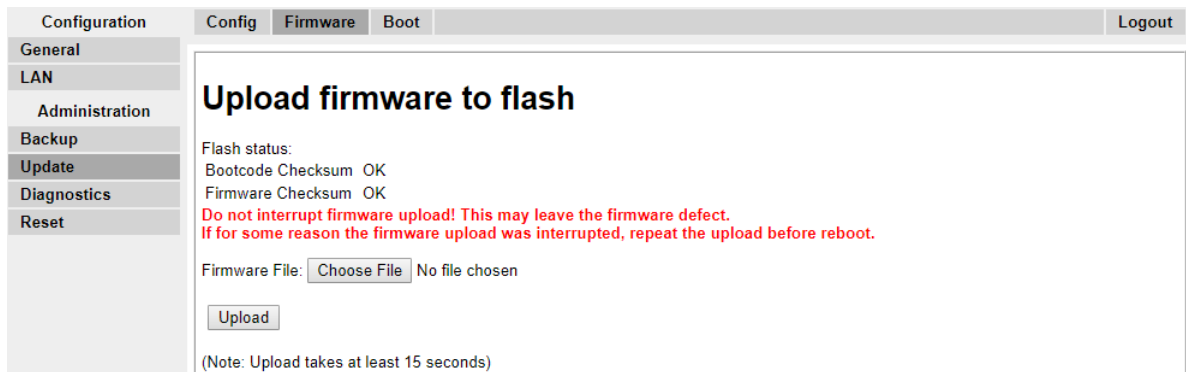

- Click on the **Browse** button and browse to the **IP Base Station** sub-folder of the Avaya Wireless DECT software you previously extracted onto the programming PC.
- Select the appropriate firmware file for the upgrade you are performing,
- Click **OK**.
- Click on the **Upload** button.

The browser shows the progress of the upload and upgrade. It will indicate when the process has been completed.

14. Click on **Reset**.
15. Log in again. The **General > Info** tab should now list the new firmware.

If necessary:

- Repeat the process for the remaining base stations using the **Update > Firmware** menu.
- Update the base station firmware for base stations that will connect to an IP DECT Gateway using the **Update > RFPs** menu.

Related links

[Configuring IP Slave Base Stations](#) on page 243

Setting a Base Station IP Address

About this task

During initial installation the IP address of a base station defaults to 192.168.0.1. The process below can be used to change the DHCP mode and IP address of a base station.

Procedure

1. From the base station configuration window, in the left-hand column, select **LAN**.
2. Select the **IP** tab.

Configuration	DHCP	IP	802.1X	LLDP	Logout
General					
LAN					
Administration					
Backup					
Update					
Diagnostics					
Reset					

		Active Settings
IP Address	<input type="text" value="192.168.0.226"/>	192.168.0.226
Network Mask	<input type="text" value="255.255.255.0"/>	255.255.255.0
Default Gateway	<input type="text" value="192.168.0.1"/>	192.168.0.1
DNS Server	<input type="text"/>	
Alt. DNS Server	<input type="text"/>	
Check ARP	<input type="checkbox"/>	

- a. Enter the required **IP Address** and **Network Mask** for the base station. The other settings are optional.
- b. Click **OK**.

 **Note:**

The menu will prompt you with the message **Reset Required**. Do not click this or reset the base station at this stage.

- c. Select the **DHCP** tab.



- d. Using the **Mode** drop-down, select **Disabled**.
- e. Click **OK**.
- f. Select **Reset** and then select the **Reset** tab.
- g. Click **OK**.
- h. Depending on your base station, wait for the LED to return to solid blue or solid green.
- i. Log in again using the new IP address.

Related links

[Configuring IP Slave Base Stations](#) on page 243

Setting a Base Station to Slave Mode

About this task

There can be only one master base station in the IP Office Avaya Wireless DECT system. In this process we check that the base station is not set to act as a master and then configure its radio settings to access the master base station.

Procedure

- 1. In the left-hand column, select **DECT**. Select the **Master** tab.

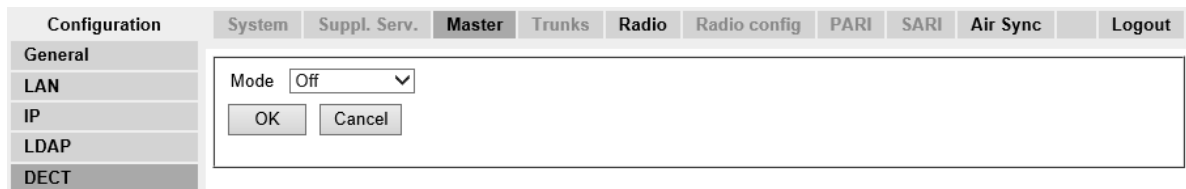

- 2. Check that the **Mode** is set to **Off**.
- 3. Click **OK**.

4. Select the **Radio** tab.

5. Set the following details:

- **Name**

Set this to match the **System Name** set on the master base station's **DECT | System** tab.

- **Password**

Set this to match the **Password** set on the master base station's **DECT | System** tab.

- **Master IP Address**

Enter the IP address of the master base station set on its **LAN | IP** tab.

- Click **OK**.

- Select the **Air Sync** tab.

- Set the **Sync Mode** to **Slave**.
- Click **OK**.

Related links

[Configuring IP Slave Base Stations](#) on page 243

Resetting a Base Station

Procedure

1. In the left-hand panel, select **Reset**. Select the **Reset** tab or **Idle-Reset** tab.

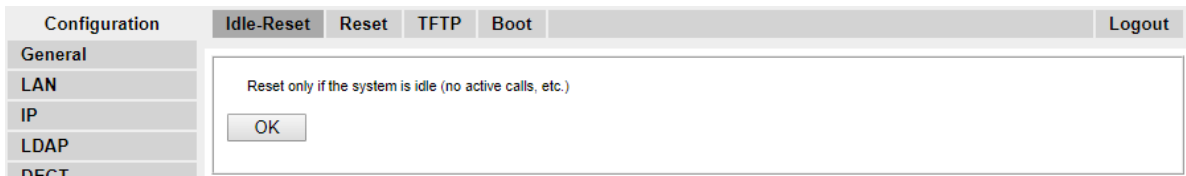

2. Click **OK**.

Related links

[Configuring IP Slave Base Stations](#) on page 243

Chapter 27: Checking a Base Station Signaling Status

To check the signaling between the base stations, use the following procedures.

Related links

[Master Base Station](#) on page 253

[Slave Base Station](#) on page 254

Master Base Station

Procedure

1. In the left-hand column select **Device Overview**. Select the **Radios** tab. The details of the base stations within the system are displayed.

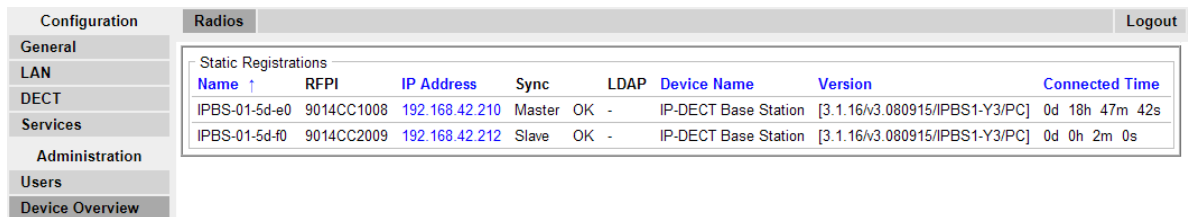

The screenshot shows the 'Radios' tab selected in the 'Configuration' menu. The main content area displays a table titled 'Static Registrations' with the following data:

Name ↑	RFPI	IP Address	Sync	LDAP	Device Name	Version	Connected Time
IPBS-01-5d-e0	9014CC1008	192.168.42.210	Master	OK -	IP-DECT Base Station	[3.1.16/v3.080915/IPBS1-Y3/PC]	0d 18h 47m 42s
IPBS-01-5d-f0	9014CC2009	192.168.42.212	Slave	OK -	IP-DECT Base Station	[3.1.16/v3.080915/IPBS1-Y3/PC]	0d 0h 2m 0s

2. Select the **Air Sync** tab. The status of wireless synchronization between the master and other base stations is displayed.

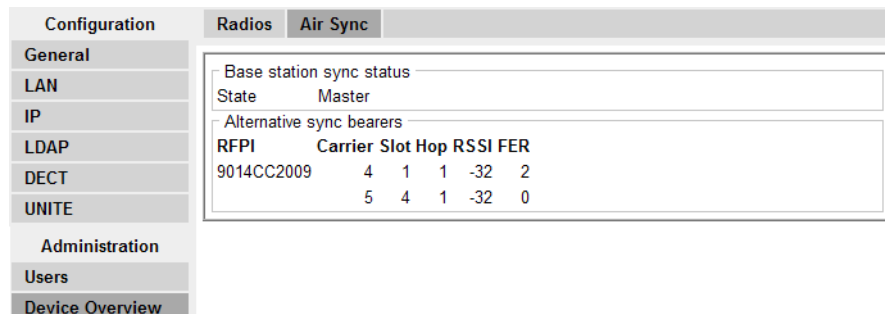

The screenshot shows the 'Air Sync' tab selected in the 'Configuration' menu. The main content area displays the following information:

Base station sync status
State Master

Alternative sync bearers

RFPI	Carrier	Slot	Hop	RSSI	FER
9014CC2009	4	1	1	-32	2
	5	4	1	-32	0

Related links

[Checking a Base Station Signaling Status](#) on page 253

Slave Base Station

Procedure

In the left-hand column select **Device Overview**. Select the **Air Sync** tab.

Configuration	Radios	Air Sync
General	Base station sync status	
LAN	State Slave, synchronized	
IP	Sync offset -96 ns	
LDAP	Drift 0.9166 PPM	
DECT	Active sync bearer	
UNITE	RFPI Carrier Slot Hop RSSI FER	
	9014CC1008 4 7 0 -38 0	
Administration	Alternative sync bearer	
Users	RFPI Carrier Slot Hop RSSI FER	
Device Overview	9014CC1008 0 11 0 -38 11	
Traffic	Counters	
Backup	Sync lost 0	
Update	Hop value 1	

Related links

[Checking a Base Station Signaling Status](#) on page 253

Chapter 28: Mounting a Base Station

About this task

The base station can now be powered down and mounted in its intended operating position. The removable bracket on the back of the base stations can be used for either wall mounting using two screws suitable for the surface or for mounting on columns using two metal bands.

Related links

[Mounting a Base Station using a Wallmount](#) on page 105

[Mounting a Base Station on a Column/Pillar](#) on page 107

Mounting a Base Station using a Wallmount

About this task

Remove the mounting bracket from the base station. Use it as a template for marking the screw fixing holes. Note the diagram below indicating the required clearance for attaching the base station onto the mounting bracket.

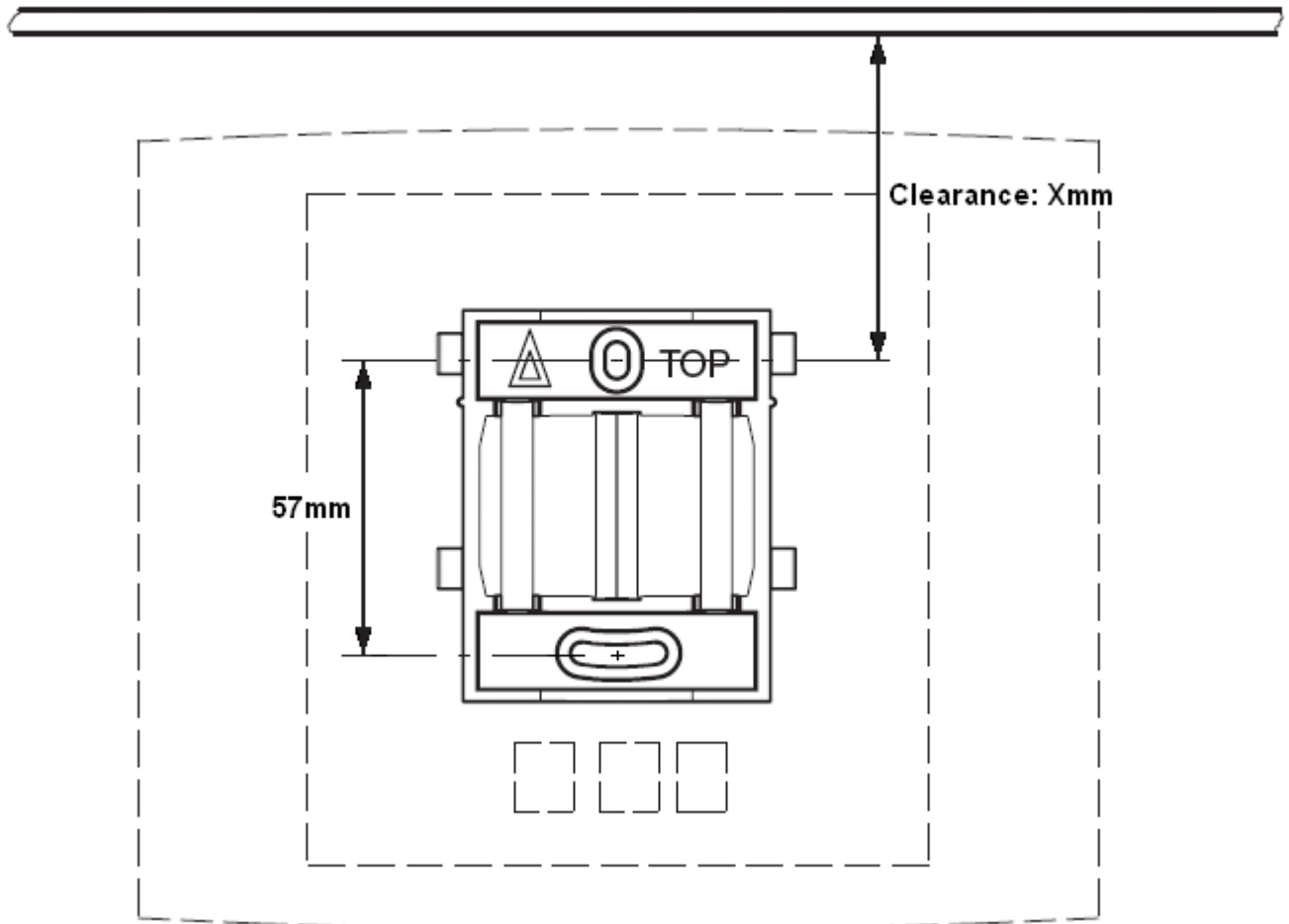

Procedure

1. Hold the mounting bracket with its flat side against the wall with the text 'TOP' upwards and mark the two holes. Observe the minimum distance between the top screw hole and the ceiling. This depends on the base station type as follows:

Base Station Type	Internal Aerials	External Aerials
IPBS1 Digital Base Station	65mm	160mm
IPBS2/IPBS3	100mm	195mm

2. Drill the two holes using a 6mm diameter drill and insert the included wall plugs.
3. Position the mounting bracket with its flat side to the wall and fasten it with the two included 3.5mm diameter screws.

Related links

[Base Station Mounting](#) on page 105

[Mounting](#) on page 143

[Mounting a Base Station](#) on page 255

Mounting a Base Station on a Column/Pillar

The mounting bracket can be fixed to a pole of 45mm diameter or greater, or a beam of 50mm width minimum by using a strap or flexible metal band less than 30 mm wide. A suitable strap or flexible metal band is not included with the base station.

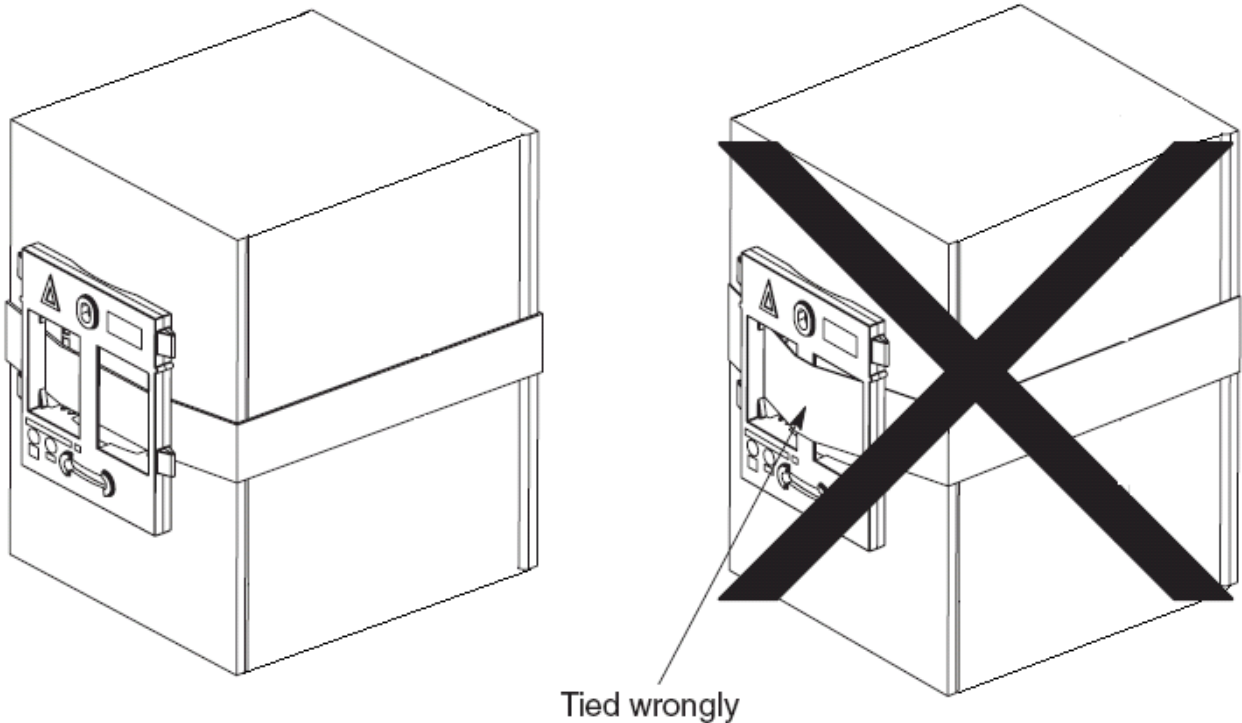

Note: Mounting a wireless base station directly on a steel beam or pillar could result in signal disruptions, such as dead zones or reflections. If it is absolutely necessary to mount the base station on a metallic surface, use spacers to separate the base station from the surface by 20-25 cm.

Related links

[Base Station Mounting](#) on page 105

[Mounting](#) on page 143

[Mounting a Base Station](#) on page 255

Chapter 29: Phone Subscription

Once the master base station has been configured and is connected to the IP Office, you can begin phone subscription.

There are two methods of subscription; anonymous phone subscription and pre-configured phone subscription. Both methods require the DECT users to be pre-configured in the master base station configuration. However, anonymous phone subscription allows the user pre-configuration to be done without knowing the IPEI of the DECT phone the user will actually use.

Related links

- [Pre-Requisites](#) on page 258
- [Allowing Subscription](#) on page 259
- [Creating User Entries](#) on page 261
- [Subscribing a Phone](#) on page 263
- [Completing Anonymous Login](#) on page 266
- [Disabling Subscription](#) on page 267

Pre-Requisites

- Master base station installed and connected to the network.
- IP Office connected to the network.

Related links

- [Phone Subscription](#) on page 258
- [Information](#) on page 258
- [Tools](#) on page 259

Information

- Service user name and password for IP Office configuration.
- User names and extension numbers for the DECT phones.
- Phone IPEI numbers if using pre-configured installation mode.

Related links

- [Pre-Requisites](#) on page 258

Tools

- **IP Office Manager.**
- **Device Manager**

The software installed on each handset may need to be upgraded to match that supplied with the Avaya Wireless DECT software. This is done using the Windows Device Manager software to upgrade phones via an advanced charger or using AIWS Device Manager to upgrade phones over the air.

- Web browser (Internet Explorer or Firefox are supported).

Related links

[Pre-Requisites](#) on page 258

Allowing Subscription

Before phones are subscribed, subscription needs to be allowed by both the IP Office and the Avaya Wireless DECT system.

Related links



[Phone Subscription](#) on page 258

[Enabling IP Office Subscription](#) on page 110

[Master Base Station](#) on page 260

Enabling IP Office Subscription

Procedure

1. Start IP Office Manager and receive the configuration from the IP Office system.
2. In the left-hand navigation pane, click on  **Line** icon.
3. Select the  **IP DECT Line**.

4. Select the **Gateway** tab.

Line Gateway VoIP

Auto-Create Extension

Auto-Create User

Enable DHCP Support

Boot File

ADMM MAC Address

VLAN ID

Base Station Address List

Add...

Remove

Edit...

Enable Provisioning

SARI/PARK

Subscriptions

Authentication Code

Enable Resiliency

Status Enquiry Period

Prioritize Primary

Supervision Timeout

5. Check that the **Auto-Create Extension** and **Auto-Create User** options are selected.

6. Click **OK**.

7. Send the configuration back to the IP Office.

Related links

[Allowing Subscription](#) on page 109

[Allowing Subscription](#) on page 259

Master Base Station

Procedure

1. Access the master base stations configuration.

2. In the left-hand panel select **DECT**. Select the **System** tab.

Configuration	System	Suppl. Serv.	Master	Trunks	Radio	Radio config	PARI	SARI	Air Sync	Logout
General										
LAN										
IP										
LDAP										
DECT										
VoIP										
Unite										
Services										
Administration										
Users										
Device Overview										
DECT Sync										
Traffic										
Backup										
Update										

System Name	DECT									
Password	••••••••									
Confirm Password	••••••••									
Subscriptions	With System AC									
Authentication Code	1234									
Default Language	English									
Frequency	Europe									
Enabled Carriers	0	1	2	3	4	5	6	7	8	9
	<input checked="" type="checkbox"/>	<input checked="" type="checkbox"/>	<input checked="" type="checkbox"/>	<input checked="" type="checkbox"/>	<input checked="" type="checkbox"/>	<input checked="" type="checkbox"/>	<input checked="" type="checkbox"/>	<input checked="" type="checkbox"/>	<input checked="" type="checkbox"/>	<input checked="" type="checkbox"/>
Coder	G729A									
Frame (ms)	60									
Exclusive	<input type="checkbox"/>									
SC	<input type="checkbox"/>									
<input type="button" value="OK"/> <input type="button" value="Cancel"/>										

3. Check that the **Subscriptions** field:

- **With System AC**

Select this option to allow anonymous subscription of phones.

- **With User AC**

Select this option to allow subscription against user entries.

- Note the number set in the **Authentication Code** field. This number is used as part of the anonymous subscription.
- Click **OK**.

Related links

[Allowing Subscription](#) on page 259

Creating User Entries

About this task

Subscription requires a user entry within the master base station configuration. On completion of subscription, matching extension and user entries are automatically created in the IP Office configuration.

Procedure

1. In the left-hand panel, select **Users** under the **Administration** menu. Select the **Users** tab.

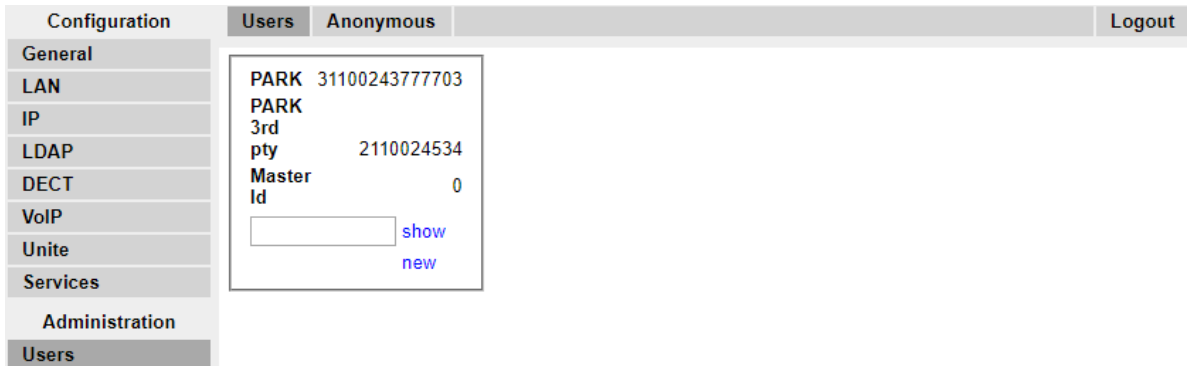

2. Click **new**. A dialogue is displayed for entry of user details.

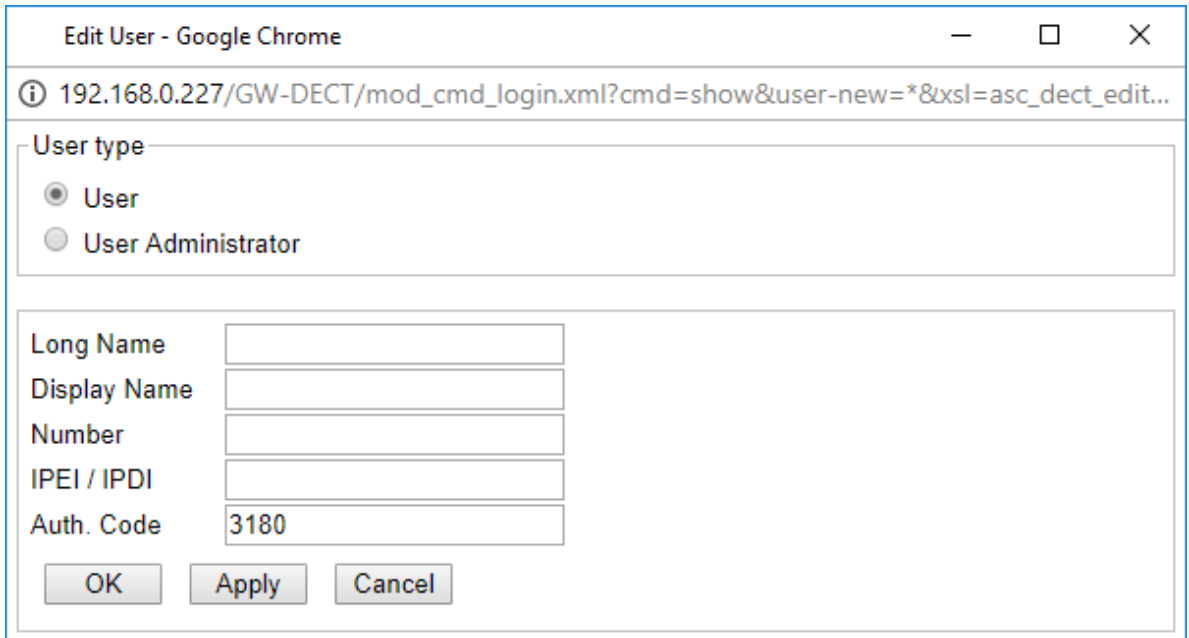

3. Enter the user details:

- **Long Name**

This name is used for information within the Avaya Wireless DECT system settings.

- **Display Name**

This name displayed on the phone when idle. It is also the name used for the user created in the IP Office configuration. The name must be unique.

- **Number**

This will be the extension number of the phone on both the IP Office and Avaya Wireless DECT systems. The number must be unique.

*** Note:**

The remaining two fields should not be completed if you want to use anonymous subscription. This removes the requirement of knowing the phone IPEI numbers during installation.

• **IPEI/IPDI**

The phones IPEI number. For 3720, 3725 phones this is printed on the label inside the phones battery compartment. The IPEI can also be viewed from the phone UI.

• **Auth. Code**

The account code that should be used when the phone is subscribed.

• Click **OK**.

• Repeat the process for any other phones that you want to subscribe.

• Within the **Users | Users** tab, click on **show** to display a list of the configured users.

The screenshot shows the Avaya user interface with the 'Users' tab selected. On the left, a navigation menu includes 'Configuration', 'Users', 'Anonymous', and 'Logout'. Under 'Configuration', options include 'General', 'LAN', 'IP', 'LDAP', 'DECT', 'VoIP', 'Unite', 'Services', 'Administration', and 'Users'. The main content area is divided into two sections. The top section, 'User Administrators', shows a list with columns 'Long Name' and 'Name', and a 'User Administrators: 0' indicator. The bottom section, 'Users', shows a table with columns: 'Long Name', 'No', 'Display', 'IPEI / IPDI', 'AC', 'Prod', 'SW', 'EE', and 'Registration'. The table contains two rows: 'Extension400' (No: 400, Display: Extn400, AC: 1945, Registration: Not Subscribed) and 'Extension401' (No: 401, Display: Extn401, AC: 1503, Registration: Not Subscribed). Below the table, it indicates 'Users: 2'. A 'show' button is visible next to the 'Master Id' field in the configuration area.

• The phones configured will be displayed. You can now begin subscribing the phones.

Related links

[Phone Subscription](#) on page 258

Subscribing a Phone

About this task

Using the Telephone user interface, perform the following procedure to subscribe the handsets.

- Switch on the phone:
 - **3720:** Select **Menu | Settings | System | Subscribe**.
 - **Others:** Select **Menu | Connections | System | Subscribe**.





Display	Actions
 <p>Abc IPDI: 0364704336127 User ID 361 Next Clear Back</p>	<p>Details of the phone's current subscription are displayed. Select Next.</p>
 <p>Abc IPDI: 0364704336127 System name _____ Next Clear Back</p>	<p>The System name is just used by the phone to identify the different subscriptions it may have. Enter any name and select Next.</p>
 <p>Subscribe <input type="radio"/> Integral 5 <input type="radio"/> Integral Ent. <input checked="" type="radio"/> IP-DECT <input type="radio"/> Other Next Clear Back</p>	<p>The phone will display a list of telephone system types to which it can connect. Scroll the selected option to IP-DECT and select Next.</p>
 <p>123 PARK: 3110024377703 AC: _____ Next Clear Back</p>	<p>The phone now requires the PARK (SARI) and AC (authentication code) of the system to which it should subscribe. Enter the PARK and then scroll to the AC field. Enter the System AC and select Next.</p>
 <p>123 PARK: 3110024377703 Protection on? Yes No Back</p>	<p>The Protection on? prompt is displayed.</p> <ul style="list-style-type: none"> • If you select No, the user can delete the subscription from the list of subscriptions known by the phone. • If you select Yes, the user cannot delete the subscription.

Table continues...

Display	Actions
	<p>A summary of the subscription details is shown. Check that the values are correct</p>
	<p>Select OK. The phone broadcast for DECT systems to which it can subscribe.</p>
	<p>When a DECT system is located, the handset will attempt to subscribe to that system.</p>
	<p>The success or failure of the subscription is indicated.</p>

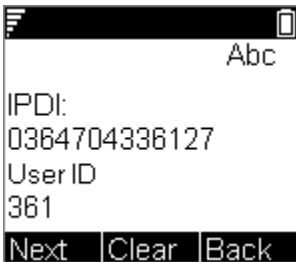
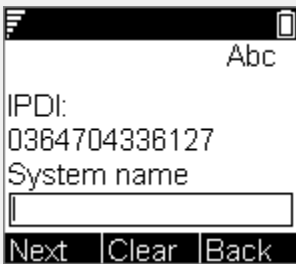
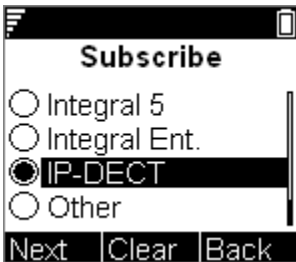
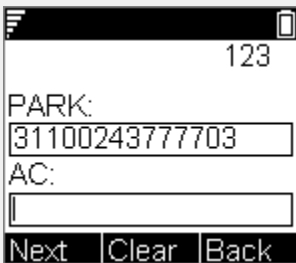
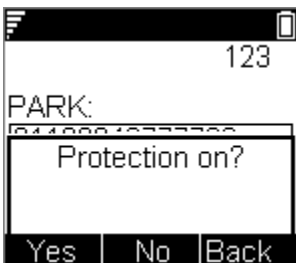
Related links

- [Phone Subscription](#) on page 258
- [3701/3711 Phone Subscription](#) on page 265

3701/3711 Phone Subscription

Procedure

1. Switch on the phone.
2. Select **Menu | System | Subscription | Subscribe HS**.
3. Select **PABX-PIN**.
4. Enter the authentication code.

Result

1. The phone is subscribed anonymously and should display **Please Login**.

Related links

[Subscribing a Phone](#) on page 263

Completing Anonymous Login

About this task

In the master base station configuration select the **Users | Anonymous** tab. This tab shows those phones currently anonymously subscribed to the DECT system. The DECT system will allow up to 8 anonymous devices to be subscribed at the same time.

Configuration	Users	Anonymous	Logout
General	036470433612 Delete		
LAN			
IP			
LDAP			
DECT			
UNITE			
Services			
Administration			
Users			

This process changes the anonymous subscription to a known subscription. While a phone is in anonymous subscription state it displays a screen showing **Please login**.

Procedure

To login, dial ***M*N*AC#** where:

- **M** is the DECT system's **Master Id**. This is shown on the base station's **Users | Users** tab.
- **N** is the extension number required. This must match an existing unsubscribed user entry on the **Users | Users** tab in the master base station configuration.
- **AC** is the **User Authentication Code**.
- For example, on a system with master ID 0, to register an anonymously subscribed device as extension 403, dial ***0*403*AC#**.

Related links

[Phone Subscription](#) on page 258

Disabling Subscription

About this task

When all DECT phones have been subscribed, Avaya recommends that you disable any further subscriptions.

Ensure that no other copies of the configuration are open in Manager during subscription, as sending such a copy of the configuration back to the IP Office system will replace the subscriptions and require the handsets to be subscribed again. Following any handset subscription, a new copy of the configuration should always be loaded in IP Office Manager if any other configuration changes are required.

Procedure

1. Access the master base station configuration.
2. In the left-hand panel select **DECT**.

Configuration	System	Suppl. Serv.	Master	Trunks	Radio	Radio config	PARI	SARI	Air Sync	Logout
General										
LAN										
IP										
LDAP										
DECT										
VoIP										
Unite										
Services										
Administration										
Users										
Device Overview										
DECT Sync										
Traffic										
Backup										
Update										

System Name	DECT
Password	••••••••
Confirm Password	••••••••
Subscriptions	With System AC ▾
Authentication Code	1234
Default Language	English ▾
Frequency	Europe ▾
Enabled Carriers	0 1 2 3 4 5 6 7 8 9 <input checked="" type="checkbox"/> <input checked="" type="checkbox"/> <input checked="" type="checkbox"/> <input checked="" type="checkbox"/> <input checked="" type="checkbox"/> <input checked="" type="checkbox"/> <input checked="" type="checkbox"/> <input checked="" type="checkbox"/> <input checked="" type="checkbox"/> <input checked="" type="checkbox"/>
Coder	G729A ▾ Frame (ms) 60 Exclusive <input type="checkbox"/> SC <input type="checkbox"/>
<input type="button" value="OK"/> <input type="button" value="Cancel"/>	

3. Select the **System** tab.
4. Select **Disabled** in the **Subscriptions** field.
5. Click **OK** to save the configuration back to the IP Office system.

Related links

[Phone Subscription](#) on page 258

Part 11: Further Help

Chapter 30: Additional Help and Documentation

The following pages provide sources for additional help.

Related links

[Additional Manuals and User Guides](#) on page 269

[Getting Help](#) on page 269

[Finding an Avaya Business Partner](#) on page 270

[Additional IP Office resources](#) on page 270

[Training](#) on page 271

Additional Manuals and User Guides

The [Avaya Documentation Center](#) website contains user guides and manuals for Avaya products including IP Office.

- For a listing of the current IP Office manuals and user guides, look at the [Avaya IP Office™ Platform Manuals and User Guides](#) document.
- [Avaya Support](#) website provides access to the IP Office technical manuals and users guides.
 - Note that where possible this site redirects users to the version of the document hosted by the [Avaya Documentation Center](#).

For other types of documents and other resources, visit the various Avaya websites (see [Additional IP Office resources](#) on page 270).

Related links

[Additional Help and Documentation](#) on page 269

Getting Help

Avaya sells IP Office through accredited business partners. Those business partners provide direct support to their customers and can escalate issues to Avaya when necessary.

If your IP Office system currently does not have an Avaya business partner providing support and maintenance for it, you can use the Avaya Partner Locator tool to find a business partner. See [Finding an Avaya Business Partner](#) on page 270.

Related links

[Additional Help and Documentation](#) on page 269

Finding an Avaya Business Partner

If your IP Office system currently does not have an Avaya business partner providing support and maintenance for it, you can use the Avaya Partner Locator tool to find a business partner.

Procedure

1. Using a browser, go to the [Avaya Website](#) at <https://www.avaya.com>
2. Select **Partners** and then **Find a Partner**.
3. Enter your location information.
4. For IP Office business partners, using the **Filter**, select **Small/Medium Business**.

Related links

[Additional Help and Documentation](#) on page 269

Additional IP Office resources

In addition to the documentation website (see [Additional Manuals and User Guides](#) on page 269), there are a range of website that provide information about Avaya products and services including IP Office.

- [Avaya Website](#) (<https://www.avaya.com>)

This is the official Avaya website. The front page also provides access to individual Avaya websites for different regions and countries.

- [Avaya Sales & Partner Portal](#) (<https://sales.avaya.com>)

This is the official website for all Avaya business partners. The site requires registration for a username and password. Once accessed, you can customize the portal to show specific products and information type that you want to see.

- [Avaya Support](#) (<https://support.avaya.com>)

This site provide access to Avaya product software, documentation and other services for Avaya product installers and maintainers.

- [Avaya Support Forums](#) (<https://support.avaya.com/forums/index.php>)

This site provides forums for discussing product issues.

- [International Avaya User Group](https://www.iuag.org) (<https://www.iuag.org>)

This is the organization for Avaya customers. It provides discussion groups and forums.

- [Avaya Learning](https://www.avaya-learning.com/) (<https://www.avaya-learning.com/>)

This site provides access to training courses and accreditation programs for Avaya products.

Related links

[Additional Help and Documentation](#) on page 269

Training

Avaya training and credentials ensure our Business Partners have the capabilities and skills to successfully sell, implement, and support Avaya solutions and exceed customer expectations. The following credentials are available:

- Avaya Certified Sales Specialist (APSS)
- Avaya Implementation Professional Specialist (AIPS)
- Avaya Certified Support Specialist (ACSS)

Credential maps are available on the [Avaya Learning](#) website.

Related links

[Additional Help and Documentation](#) on page 269

Glossary

The following are definitions for common abbreviations used within the Avaya Wireless DECT system applications:

Item	Definition
AIWS	Avaya In-Building Wireless Server
CAP	Common Access Profile
DECT	Digital Enhanced Cordless Telecommunications; global standard for cordless telephony.
ELISE	Embedded Linux SErver; a term for the AIWS.
FER	Frame Error Rate
GAP	Generic Access Profile; DECT standard.
IPBS	IP-DECT Base Station
IPDI	At delivery of the telephone, IPEI and IPDI are the same and either can be used for network subscription. If one telephone is replaced with another using the Easy replacement procedure the IPDI will be exchanged and IPEI and IPDI will no longer be the same. If the IPEI and the IPDI differ, the IPDI shall be used for network subscription.
IPEI	International Portable Equipment Identity; the unique global GAP identity number for the phone. This code is needed for the system administrator to enable network subscription.
PARI	Primary Access Rights Identity
PARK	Portable Access Rights Key
PBX	PBX Private Branch Exchange; the telephone system within an enterprise that switches calls between local lines and allows all users to share a certain number of external lines.
PDM	Portable Device Manager
PP	Portable Part; a term for DECT phones.
RFP	Radio Fixed Part; a term for DECT base-stations.
RFPI	Radio Fixed Part Identity
SARI	Secondary Access Rights Identifier
SS	Signal Strength
SST	Site Survey Tool
WSM	Wireless Services and Message; the module that enables wireless services like central phone book and messaging to and from the portable devices (an alternate term for the AIWS).

Index

Special Characters

*17 [233](#)

Numerics

1720 [235](#)
192.168.0.1 [76](#)
3700 [12](#)
3720 [28](#)
3725 [28](#)
3725 Site Survey Mode [57](#)

A

Administrator [269](#)
Aerials [17](#), [23](#)
Air Sync [93](#), [238](#)
air synch master [56](#)
AIWS [12](#), [43](#)
 Browse [178](#)
 Cover [174](#)
 Device Manager [155](#)
 IP Address [198](#)
 Replacing the Cover [195](#)
 Status Lamp [45](#)
 Switch Off [194](#)
 Upgrade [207](#)
 Wall Mount [194](#)
Allow Subscription [109](#), [259](#)
Anonymous Login [266](#)
Antenna [23](#)
APIs [270](#)
Application Notes [270](#)
Auth. Code [261](#)
Authentication Code [109](#), [231](#), [259](#)
Avaya In-Building Wireless Server [12](#), [43](#)

B

Backs up my IP DECT Phones [134](#)
Base Station [12](#), [17](#)
 Access the Configuration [76](#), [97](#), [223](#), [246](#)
 Browse [76](#), [97](#), [223](#), [246](#)
 IP Address [78](#), [98](#), [227](#), [249](#)
 Location [136](#)
 Mounting [105](#)
 Reset [241](#), [252](#)
 Reset Switch [15](#)
 Restart [15](#)
 Status Lamps [22](#)
 Time Source [230](#)

Base Station Mirroring [126](#)
Battery [28](#)
 AIWS [177](#)
 RTC [177](#)
Bear [57](#)
Bluetooth [28](#)
Bracket [17](#)
Browse
 AIWS [178](#)
 Base Stations [76](#), [97](#), [223](#), [246](#)
Building Layout [57](#)
business partner locator [270](#)

C

C7 S10 [57](#)
Call Based Location Information [136](#)
Call list [28](#)
CAP [28](#)
Chargers
 Advanced Charger [12](#), [41](#)
 Basic Charger [12](#), [41](#)
 Battery Charger [12](#), [41](#)
 Rack Charger [12](#), [41](#)
Class 2 [17](#)
Codecs [68](#)
Column Mounting [105](#)
courses [270](#)
Cover
 Remove [174](#)
 Replacing [195](#)
Coverage [52](#)
Coverage pattern [17](#)
Create User Entries [261](#)
CS IP Address [235](#)
CS Port [235](#)

D

Date and Time [198](#)
DECT [12](#)
DECT Info [57](#)
DECT phones [28](#)
DECT R4.zip [63](#)
Default Language [231](#)
default the base station [76](#)
Device Manager [155](#), [168](#)
 AIWS [155](#)
 WinPDM [155](#)
Device Overview [253](#)
Directional Dual Aerial [23](#)
Directional Single Antenna [23](#)
Directory Integration [12](#), [240](#)

Disable Subscription	267	Language	231
Display Name	261	Languages	28
E		LED Indication	101 , 250
Edit Templates	162	License	12
Emergency calls	136	Local Port	235
Enable Supplementary Services	233	Location	136
Error rate	57	Login	266
External aerials	17	Long Name	261
F		Loudspeaker	28
Factory reset	15	M	
Fire Doors	52	Manuals	269
Firmware	63 , 81	Master base station	17
Upgrade Base Station	81 , 99 , 224 , 247	Master Base Station	231
Fix Message Center No	233	Configuration	220
forums	270	Master IP Address	101 , 235 , 250
Frequency	231	Mirroring	126
G		Mounting	
G.722	68	AIWS	194
GAP	28	Base Station	105
H		N	
Handover	55	Name	
Hands free	28	Display	261
Handset configuration	43	Long	261
Help	269	New	14
Host Name	198	NTP Time Server	198
I		Number	261
Idle-Reset	241	Number of base stations	52 , 54
IEEE 802.3af	17	Number of Calls	17
Internal aerials	17	O	
IP Address		Omni-Directional	23
AIWS	198	OPUS	68
Base Station IP Address	78 , 98 , 227 , 249	Overlap	52 , 54
IP DECT Base Station	12	P	
IP LAN	12	PARI	57 , 92 , 237
IP Office		Pari, Radio, RFP	91 , 236
Directory Integration	240	Park	57
Location	136	PARK	238
IP Office Release	12	Password	231
IP44	28	PBX	234
IPBS	12	PDM	155
IPDI	261	Phone	
IPEI	261	Edit template	162
L		Login	266
LAN sockets	12	Software upgrade	117
		Subscription	258
		Template Files	160
		Phone Subscription	263
		Phone Templates	

Phone Templates (<i>continued</i>)		Starting	
Upload	158	AIWS Device Manager	155
Phonebook Properties	198	Windows Device Manager	168
Phones	28	Status Lamp	
Pillar Mounting	105	AIWS	45
PoE	17	Status Lamps	
Portable Device Manager	155	Base Station	22
Power over Ethernet	17	Subnet Mask	198
Protocol	234	Subscription	
Q		Allow	109 , 259
Q2 Error rate	57	Disable	267
QoS	231	Login	266
Quick Reference Guides	269	Phone	263
R		Phone Subscription	258
Rack Chargers	52	Subscriptions	231
Radio coverage	17	Supplementary Services	233
Range	52	support	270
Removing the AIWS Cover	174	Supported firmware	63
Replacing the AIWS Cover	195	Supports Fallback	134
Reseller	269	Switch Resilience	126
Reset	241	Switching Off	
Base Station	241 , 252	AIWS	194
reset switch	76	Sync Mode	101 , 250
Reset Switch	15	synchronized	56
Resilience	126	System Administrator	269
Restart	15	System Name	231
Roaming	55	T	
RTC Battery	177	Technical Bulletin	207
S		Technical Bulletins	63 , 270
S10	57	Technical Tips	63
sales	270	Template	160
SARI	238	Edit	162
SCN Backup Options	134	TFTP	198
Screened Rooms	52	Time	
SDKs	270	Base Station Time Source	230
Separated Locations	56	Speech	28
Setup Wizard	198	Standby	28
Simultaneous calls	17	Time Server IP Address	198
Site Survey	52 , 54	ToS	231
Site Survey Mode	57	training	270 , 271
Slave Mode	101 , 250	U	
SMS	12 , 28	Unpack the software	63
SMS messaging	43	Upgrade	
Software	63	AIWS Firmware	207
Upgrade Base Station	81 , 99 , 224 , 247	Base Station Firmware	81 , 99 , 224 , 247
Software upgrades	43	Phone Software	117
Speech Time	28	upgraded	81
ss	57	Upload	
Stair Wells	52	Phone templates	158
Standby Time	28	USB	12 , 41
		User Guides	269

V

VCM	12
Vibrator	28
VLAN	79 , 228

W

Wall Mount	
AIWS	194
Wall Mounting	105
websites	270
Windows Device Manager	168
Windows Portable Device Manager	155
WinPDM	155
Wireless	
Handset configuration	43
Software Upgrade	43
With System AC	109 , 231 , 259
With User AC	109 , 259