



# **IP Office Voicemail Pro Example Exercises**

# Notices

© 2026 Avaya LLC. All Rights Reserved.

You may, at your own risk, assemble a MyDocs collection solely for your own internal business purposes, which constitutes a modification to the original published version of the publications. Avaya shall not be responsible for any modifications, additions, or deletions to the original published version of publications. You agree to defend, indemnify and hold harmless Avaya, Avaya's agents, servants and employees against all claims, lawsuits, demands and judgments arising out of, or in connection with, your modifications, additions or deletions to the publications.

A single topic or a collection of topics may come from multiple Avaya publications. All of the content in your collection is subject to the legal notices and disclaimers in the publications from which you assembled the collection. For information on licenses and license types, trademarks, and regulatory statements, see the original publications from which you copied the topics in your collection.

Except where expressly stated by Avaya otherwise, no use should be made of materials provided by Avaya on this site. All content on this site and the publications provided by Avaya including the selection, arrangement and design of the content is owned by Avaya and/or its licensors and is protected by copyright and other intellectual property laws including the sui generis rights relating to the protection of databases. Avaya owns all right, title and interest to any modifications, additions or deletions to the content in the Avaya publications.

# Contents

<b>Part 1: Preparation</b> .....	5
<b>Chapter 1: Introduction</b> .....	6
System Configuration.....	6
Importing an example exercise.....	7
<b>Part 2: Creating an Auto-Attendant</b> .....	9
<b>Chapter 2: Creating a New Module</b> .....	10
Adding a New Module.....	10
Creating a Short Code for Internal Calls.....	12
Creating the External Call Routing.....	12
<b>Chapter 3: Recording Entry Prompts</b> .....	14
Recording the announcement.....	14
Setting Up the Recordings Module.....	15
Adding a Short Code to Access the Recordings Module.....	17
<b>Chapter 4: Adding Additional Features to the Auto-Attendant</b> .....	18
Adding a Menu Timeout.....	18
Adding a ? Wild Card in a Menu.....	19
Using a \$ Wild Card in a Menu.....	21
Using the Generic Action.....	22
Add a Home Action to Restart the Call Flow.....	24
<b>Chapter 5: Collecting Information from a Caller</b> .....	27
Adding a Voice Question Action.....	27
<b>Chapter 6: Collecting Group Messages</b> .....	32
Enabling Group Message Waiting Indication.....	32
Setting a Group Remote Access Code.....	33
<b>Chapter 7: Using a Whisper Action</b> .....	34
Adding a Whisper Action.....	35
<b>Chapter 8: Using a Call List Action</b> .....	37
Adding a Call List Action.....	37
<b>Chapter 9: Using the Condition Editor</b> .....	40
Creating the Attendant Hours Condition.....	41
Using the Condition.....	41
Adding the Out of Hours Service.....	43
<b>Chapter 10: Using User Defined Variables</b> .....	45
Creating a New Variable.....	46
Creating Modules to Alter the Variables Value.....	46
Adding Short Codes to Change the Variable Value.....	47
Using the Variable in the Call Flow.....	48
Combining the Controls.....	49

<b>Chapter 11: Module Returns and Reusing Modules</b> .....	51
Creating the Module for Reuse.....	52
Adding the Module.....	53
<b>Part 3: Creating a Hunt Group Callflow</b> .....	55
<b>Chapter 12: Creating a Hunt Group Attendant</b> .....	56
Add the Sales Group Attendant.....	56
<b>Chapter 13: Using a Queue Position Action</b> .....	58
Adding a Queued Message.....	58
Creating the Queued Call Flow.....	59
<b>Chapter 14: Adding a Queue ETA Action</b> .....	60
Add an ETA Message.....	60
Adding the Queue ETA Action.....	61
<b>Chapter 15: Still Queued</b> .....	62
Recording a Sales Still Queued Message.....	62
Adding the Still Queued Actions.....	62
<b>Chapter 16: Forwarding Messages to Multiple Users</b> .....	64
Creating the Module to Record and Forward the Message.....	64
Adding a short code.....	65
<b>Part 4: Creating a Personal User Callflow</b> .....	66
<b>Chapter 17: Create an User Auto-Attendant</b> .....	67
Creating a Personal Attendant for a User.....	67
Using a Default Start Point.....	68
<b>Chapter 18: Using an Assisted Transfer Action</b> .....	70
Adding the Assisted Transfer Action.....	70
Adding a Number Unavailable Prompt.....	71
<b>Chapter 19: Using a Play Configuration Menu Action</b> .....	73
Adding a Play Configuration Menu Action.....	73
<b>Chapter 20: Using an Alarm Set Action</b> .....	75
Using the Alarm Set Action.....	75
Using the Clock Action.....	76
Triggering Actions for Other Users.....	77
<b>Chapter 21: Using a Callback Start Point</b> .....	78
Setting Up the Callback Call Flow.....	78
Setting the Callback Number.....	79
<b>Chapter 22: Triggering Actions for Other Users</b> .....	80
Adding a Post Dial Action.....	80
<b>Part 5: Using Campaigns</b> .....	82
<b>Chapter 23: Using Campaigns</b> .....	83
Creating the Campaign.....	83
Getting Callers to the Campaign (Part 1).....	86

Getting Callers to the Campaign (Part 2).....	87
Getting Callers to the Campaign (Part 3).....	87
<b>Chapter 24: Collecting the Campaign Results</b> .....	<b>89</b>
Using a DSS Key.....	90
Using the Campaign Action to Collect Messages.....	91
Using a Short Code to Collect Campaign Messages.....	92
<b>Part 6: Miscellaneous</b> .....	<b>93</b>
<b>Chapter 25: The NameWavs Table</b> .....	<b>94</b>
Amending the Recordings Module.....	94
Recording Names to be used with a Call List Action.....	95
<b>Part 7: Further Help</b> .....	<b>97</b>
<b>Chapter 26: Additional Help and Documentation</b> .....	<b>98</b>
Additional Manuals and User Guides.....	98
Getting Help.....	98
Finding an Avaya Business Partner.....	99
Additional IP Office resources.....	99
Training.....	100

# Part 1: Preparation

# Chapter 1: Introduction

The exercises described in this document will help you learn how you can configure and customize the operation of your Voicemail Pro voicemail services. It assumes that you are familiar with the IP Office telephone system and have access to both the IP Office and Voicemail Pro to configure both.

Performing the exercises in sequence helps you learn the following:

- Set up an auto-attendant.
- Route callers to the auto-attendant.
- Use different menu options.
- Re-record prompts via telephone.
- Use modules and access them from a telephone.
- Reuse modules in other call flows.
- Set up conditions.
- Customize a call flow for users collecting and leaving messages.
- Customize messages, and the available actions, for queued callers.
- Use campaigns to let Voicemail Pro act as an automatic call center.

**\* Note:**

- Some screenshots have been modified to improve the clarity of the callflow.
- The callflows in these exercises are examples only and not intended to reflect a real-life customer auto-attendant and other voicemail functions.

## Related links

[System Configuration](#) on page 6

[Importing an example exercise](#) on page 7

---

## System Configuration

Using IP Office Manager, set up the following users and groups on the telephone system. As with a real customer voicemail installation, setting up the users and groups correctly before installation of voicemail is important. Voicemail is based on the mailboxes on user and hunt group names, so changing a name creates a new mailbox.

**Warning:**

- Only perform these exercises on a test setup.

**Before you begin**

Ensure that you keep the IP Office configuration in its default settings.

**Procedure**

1. Start IP Office Manager and set the system configuration.
2. Edit the **Users**.
3. If necessary, edit the **Extensions** to match the following. The settings for any other extensions are not critical.

Extension	User Name
207	Bob Rogers
208	Kate Smith

4. Edit the **Hunt Group** settings to create the following groups:

Group	ID	Type	Members
Reception	300	Sequential	207
Sales	301	Sequential	208
Support	302	Sequential	207,208
Accounts	303	Sequential	207,208

5. Merge the configuration changes.
6. Make test calls to the extensions and groups to check the setup.

**Related links**

[Introduction](#) on page 6

---

## Importing an example exercise

You can download the example exercise from <http://ipofficekb.avaya.com/ipoffice/vmpro/index.htm>.

**Warning:**

- Only perform these exercises on a test machine. Any existing modules with the same name are overwritten when the zip file contents are imported.

**Procedure**

1. Open Voicemail Pro Client.
2. From the **File** menu, select **Import or Export**.

3. Select **Import call flows**.
4. Click **Next**.
5. In the **Import call flows from which file?** field click  **Browse**.
6. Select the **voicemail\_pro\_exercises\_callflows** folder.
7. Select the required exercise module to import.
8. Click **Open**. The Import or Export call flows window are displayed.
9. Click **Next**. The details of the selected module is displayed.
10. Click **Finish**. The selected call flow is imported.
11. Click **Close**.

**Related links**

[Introduction](#) on page 6

# Part 2: Creating an Auto-Attendant

# Chapter 2: Creating a New Module

This exercise helps you learn to use Voicemail Pro to add a basic auto-attendant. In the exercise, you will create an auto-attendant that gives callers a choice from a menu to transfer to the Sales, Support, or Reception group.

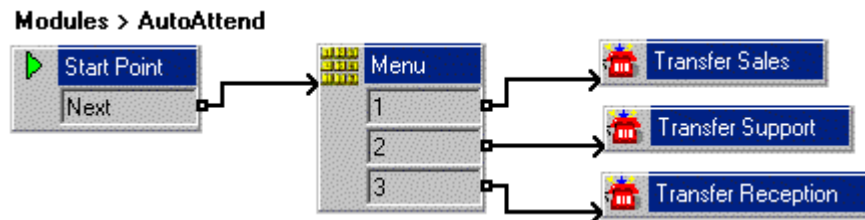

## Related links

[Adding a New Module](#) on page 10

[Creating a Short Code for Internal Calls](#) on page 12

[Creating the External Call Routing](#) on page 12

---





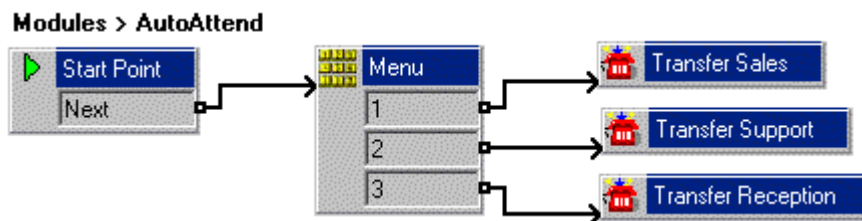





## Adding a New Module

This section describes creating a new module and adding a callflow to it.



## Procedure

1. Go to **Start > Programs > IP Office**, and open Voicemail Pro.
2. Right-click  **Modules** and select **Add**.
3. In the **Name** field, type **AutoAttend** and click **OK**. The **Start Point** is placed in the details pane.

4. Do the following to add a menu to **Start Point**.
  - a. Select the **Start Point** action.
  - b. Click the  **Basic Actions** icon and select  **Menu**.
  - c. Click the **Details** pane to place the action.
5. Do the following to add the menu options **1, 2, and 3**.
  - a. Right-click the  **Menu** icon and select **Properties**.
  - b. In the **Touch Tones** tab, click **1, 2, and 3**, and click **OK**.
6. Do the following to add the transfer locations of **Sales, Support, and Reception** groups.
  - a. Click the  **Telephony Actions** icon and select  **Transfer**.
  - b. Click the **Details** pane to place the action.
  - c. Double-click the **Transfer** action to open the **Properties** for transfer.
  - d. In the **General**, tab change the **Token Name** to **Transfer Sales**.
  - e. Select the **Specific** tab.
  - f. Type the destination as **Sales** (or 301).
  - g. Click **OK**.
7. Repeat the steps to create a transfer action for **Support** (302) and **Reception** (300).
8. Do the following to connect the actions.
  - a. Click the  **Connection** icon on the toolbar and connect the **Start Point Next** result and drag to the  **Menu**.
  - b. Do the following for the **Menu** options to be connected to the transfer locations:
    - a. Connect **1** to  **Transfer Sales**.
    - b. Connect **2** to  **Transfer Support**.
    - c. Connect **3** to **Transfer Reception**.
9. Click the  **Save & Make Live** icon.
10. Click **Yes** to make the changes permanent.

### Next steps

- Having added the new module, you can now add a short code to route internal calls to the module. Go to [Creating a Short Code for Internal Calls](#) on page 12.

### Related links

[Creating a New Module](#) on page 10

---

## Creating a Short Code for Internal Calls

Having adding a module for our auto-attendant (see [Adding a New Module](#) on page 10), we want to be able to call it internally. You can do this by adding a short code.

Doing this allows you to:

- Make test calls to you auto-attendant when making changes.
- In real operation, users on your system can transfer misdirected callers back to the auto-attendant using the short code.

### Procedure

1. In IP Office Manager, add the following short code. This example uses \*90, but you can use any short code.
  - a. In **Code** enter \*90.
  - b. In **Feature** enter `Voicemail Collect`.
  - c. In **Telephone Number** enter `"AutoAttend"`.
  - d. In **Line Group ID** enter 0.
2. Save and merge the configuration to the telephone system.
3. Dial **\*90** from any extension other than 207 to test the short code.
4. Press **3**. You are transferred to the **Reception** group. In this example, extension 207.

### Next steps

- You now also want to route external calls to your auto-attendant. Go to [Creating the External Call Routing](#) on page 12.

### Related links

[Creating a New Module](#) on page 10

---

## Creating the External Call Routing

In the IP Office system configuration, the **Incoming Call Route** entries are used to route external callers. For our example we want to direct all external callers to our auto-attendant ([Adding a New Module](#) on page 10).

### Procedure

1. In IP Office Manager, select the default **Incoming Call Route** for **Any Voice**.
2. In the **Destination**, enter **VM:AutoAttend**. This special code uses the name of the module that was added containing the auto-attendant callflow.
3. Click **OK**.

4. Save and send the configuration to the telephone system.
5. If you have an external phone set up, make an incoming call.
6. Press **3**. You are transferred to the **Reception** group. In this example, extension 207.

### Next steps

- You now have a basic auto-attendant which your IP Office system uses to answer external calls. However, we have not yet recorded any prompts for this auto-attendant. Go to [Recording Entry Prompts](#) on page 14.

### Related links

[Creating a New Module](#) on page 10

# Chapter 3: Recording Entry Prompts

Whilst adding actions and creating a callflow, you need to also record prompts to direct the callers. For example, to inform them about which options are available. Each action in a callflow can have its own set of entry prompts if required.

In this section of the document, we record some prompts. We will also create a separate callflow for re-recording prompts from any internal extension.

## Related links

[Recording the announcement](#) on page 14

[Setting Up the Recordings Module](#) on page 15



[Adding a Short Code to Access the Recordings Module](#) on page 17



---

## Recording the announcement

In this exercise, we will add a new prompt for our auto-attendant. This will tell callers what options are available.

### Procedure

1. Select the **AutoAttend** module.
2. Open **Properties** for the  **Menu** action.
3. In the **Entry Prompts** tab, click **+ Add a Prompt** icon. The Wave Editor window opens.
4. Do the following to record a prompt:
  - a. Click the **Use which media device?** arrow and select **Telephony Handset**.
  - b. In **Extensions**, type the extension number to record from.
  - c. In **Please select a file or enter a new file name**, type `attendant.opus`.
  - d. Select  **Record**. The telephone corresponding to the extension number entered rings, and you can start to record the prompt.
  - e. For our example, the prompt will be the following: *Welcome to Avaya. Please press 1 for Sales, 2 for Support, 3 for Reception, or 4 to dial the extension you want if known. Alternatively, hold for further assistance. Thank you.*
  - f. Click  **Stop** when you finish the recording.

- g. Click  **Play** to reply to the recorded message.
  - h. **(Optional)** To re-record the message, select  **Record**.
  - i. When recording is complete, replace the telephone handset.
5. Select **Close** and **OK**.
  6. Click the  **Save & Make Live** icon.
  7. Make a test call to the auto-attendant, dial **\*90**. You should hear the prompt.

### Next steps

- Having added a prompt for our auto-attendant, we will now also add a callflow that lets internal users re-record the prompt when necessary. Go to [Setting Up the Recordings Module](#) on page 15.

### Related links

[Recording Entry Prompts](#) on page 14

---

## Setting Up the Recordings Module











We can create a module that can be used to rerecord our existing prompt. The files can then be easily amended when required using a telephone.

The following is an image of a completed call flow:



### Procedure

1. Do the following to create a new module:
  - a. Right-click  **Modules** and click **Add**. The Adding a new start point window opens.
  - b. In **Name**, type `Recordings`.
  - c. Click **OK**.
  - d. Open the **Properties** for the **Start Point** in the details pane.
  - e. Select the General tab.
  - f. In the **Pin** field, enter a code that will be requested for access to following actions in the callflow.

2. Do the following to add **Menu**. We are doing this so that in future we can add options to re-record other prompts.
  - a. Click the  **Basic Actions** icon and select  **Menu**.
  - b. Click the **Details** pane to place the action.
  - c. Right-click the  **Menu** action and select **Properties**.
  - d. In the **Touch Tones** tab, select **1**.
  - e. Click **OK**.
3. Do the following to edit **Play List**:
  - a. Click the  **Configuration Actions** icon, select **Edit Play List**.
  - b. Click the **Details** pane to place the action.
  - c. Right-click the  **Edit Play List** action and select **Properties**.
  - d. Click the **General** tab. In **Token Name**, type `Edit attendant.opus`.
  - e. Click the **Specific** tab.
  - f. In **File path**, click  **Browse**. The Wave Editor window opens.
  - g. In **Please select a file or enter a new file name**, click  **Browse**.
  - h. Select the `attendant.opus` file.
  - i. Click **Open**.
  - j. Click **Close**.
  - k. Click **OK**.
4. Do the following to add connections:
  - a. Click  **Connection**.
  - b. Start Point to the  **Menu**.
  - c. Set **1** to the **Edit Play List** action.
5. Click the  **Save & Make Live** icon.

### Next steps

- We now need a short code that allows access to our module for re-recording the prompt. Go to [Adding a Short Code to Access the Recordings Module](#) on page 17.

### Related links

[Recording Entry Prompts](#) on page 14

---

## Adding a Short Code to Access the Recordings Module

Having created a module to re-record the auto-attendant prompt ([Setting Up the Recordings Module](#) on page 15), we need to be able to call the module. This can be done by adding a short code for the module.

### Procedure

1. In IP Office Manager, add the following system short code:
  - a. In **Code**, enter \*80.
  - b. In **Feature**, enter `Voicemail Collect`.
  - c. In **Telephone Number**, enter "Recordings".
  - d. In **Line Group ID**, enter 0.
2. Save and merge the configuration to the telephone system.
3. Dial \*80 from any extension.
4. Enter pin 1234.
5. Press 1. You should hear the existing auto-attendant announcement and then options to change it if necessary.

### Related links

[Recording Entry Prompts](#) on page 14

# Chapter 4: Adding Additional Features to the Auto-Attendant

Previously we created a simple auto-attendant with a choice of 3 transfer options for callers. Now we can start adding additional features.

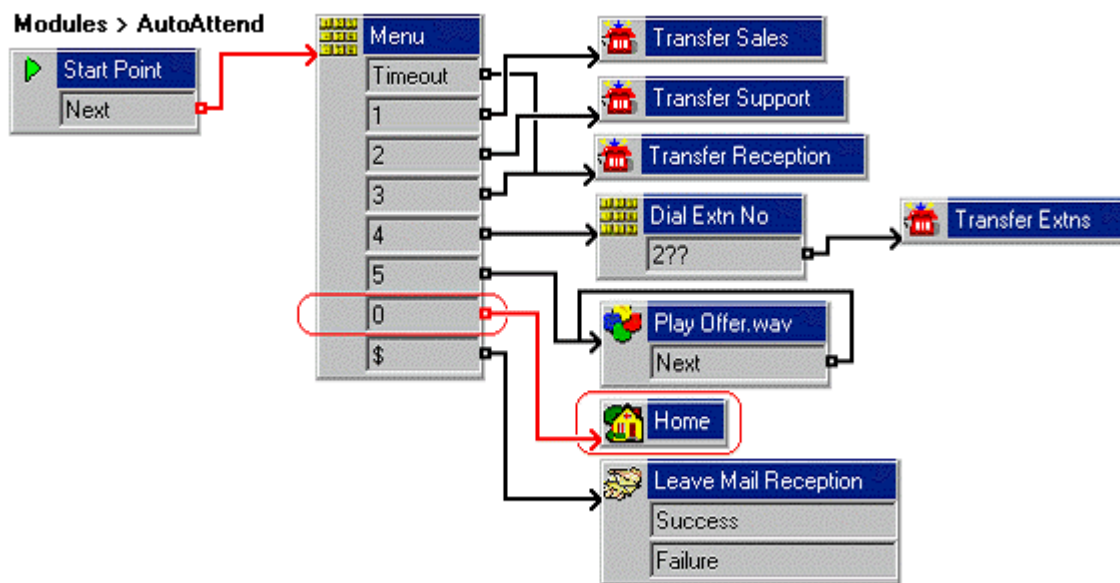

## Related links

- [Adding a Menu Timeout](#) on page 18
- [Adding a ? Wild Card in a Menu](#) on page 19
- [Using a \\$ Wild Card in a Menu](#) on page 21
- [Using the Generic Action](#) on page 22
- [Add a Home Action to Restart the Call Flow](#) on page 24

---

## Adding a Menu Timeout

You can add a **Timeout** option to the **Menu** to transfer callers to **Reception** through this exercise. When a caller does not make a **Touch Tones** selection, they are transferred to the **Reception** group.

The following is an image of a completed call flow:

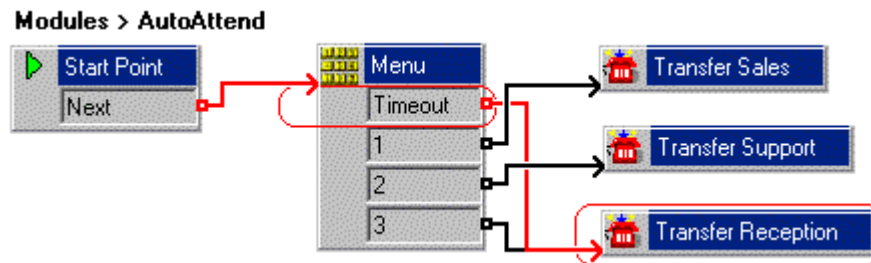

The red arrow or arrows in the call flow are the changes added in this section.

## Procedure

1. Do the following to add the **Timeout** option to the **Menu** action:
  - a. Select the **AutoAttend** module.
  - b. Open **Properties** for the **Menu** action.
  - c. Select the **Touch Tones** tab.
  - d. Select the option **Wait for a key press for up to** and enter 8.
  - e. Select **OK**. The **Menu** action has a **Timeout** result.
2. Connect the **Timeout** result to **Transfer Reception**.
3. Click the **Save & Make Live** icon.
4. Click **Yes** to make the changes permanent.
5. To test the new menu item, from any extension other than 207, make a test call to the auto-attendant module by dialing **\*90**. After eight seconds, the call is transferred to extension 207.

## Next steps

- We will now look at using wildcards in our auto-attendant's **Menu** action. Go to [Adding a ? Wild Card in a Menu](#) on page 19.

## Related links

[Adding Additional Features to the Auto-Attendant](#) on page 18

---

## Adding a ? Wild Card in a Menu

We want callers to be able to enter the number of the extension to which they want to be transferred themselves. In our example auto-attendant we can do this using another **Menu** action and some wildcards.

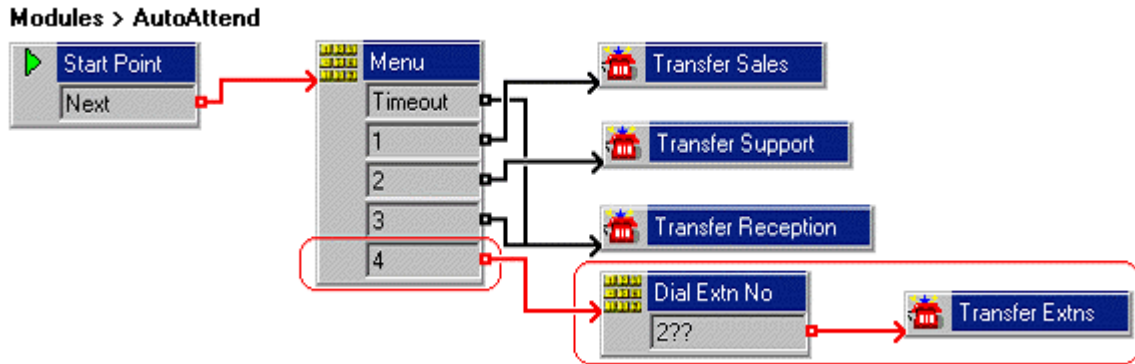

The following is an image of a completed call flow:



The red arrow or arrows in the call flow are the changes added in this section.

## Procedure

1. Do the following to add a new option to the **Menu**.
  - a. Select the **AutoAttend** module.
  - b. Open **Properties** for the **Menu** action.
  - c. In the **Touch Tones** tab, select **4** and click **OK**.
2. Do the following to add a new **Menu** action containing the touch-tone option **2??** (the touch-tone option **2??** needs to be put in a separate **Menu** action as there are **2** in our first one and that would override **2??** if in the same menu.).
  - a. Click the **Basic Actions** icon and select **Menu**.
  - b. Click the **Details** pane to place the action.
  - c. Open the **Properties** for the new **Menu** action.
  - d. In the **General** tab, change the **Token Name** to **Dial Extn No**.
  - e. In the **Touch Tones** tab, click the **Add** icon. The Add Touch Tone Sequence window opens.
  - f. In **Sequence**, enter **2??**.
  - g. Click **OK** twice.
3. Do the following to add a new **Transfer** action.
  - a. Click the **Telephony Actions** icon and select **Transfer**.
  - b. Click the **Details** pane to place the action.
  - c. Open the **Properties** for the new **Transfer** action.
  - d. In the **General** tab, change the **Token Name** to **Transfer Extn**.
  - e. In the **Specific** tab, click the **Browse** icon. The **Possible entries** window opens.
  - f. Select **System Defined Variables** and **"\$KEY" Holds the last DTMF series**.

- g. Click **OK** twice.
4. Click the  **Connection** icon on the toolbar and connect the following:
  - a. Connect **4** to  **Dial Extn No**.
  - b. Connect **2??** to **Transfer Extn**.
5. Click the  **Save & Make Live** icon.
6. Do the following to test the new menu item.
  - a. To make a test call to the auto-attendant module, dial **\*90**.
  - b. Dial **4**.
  - c. Enter an extension number (other than the one from which you are calling). The call is transferred to the extension.

### Next steps

- We can also use a wildcard to match dialing that does not have any other match. Go to [Using a \\$ Wild Card in a Menu](#) on page 21.

### Related links

[Adding Additional Features to the Auto-Attendant](#) on page 18

---

## Using a \$ Wild Card in a Menu



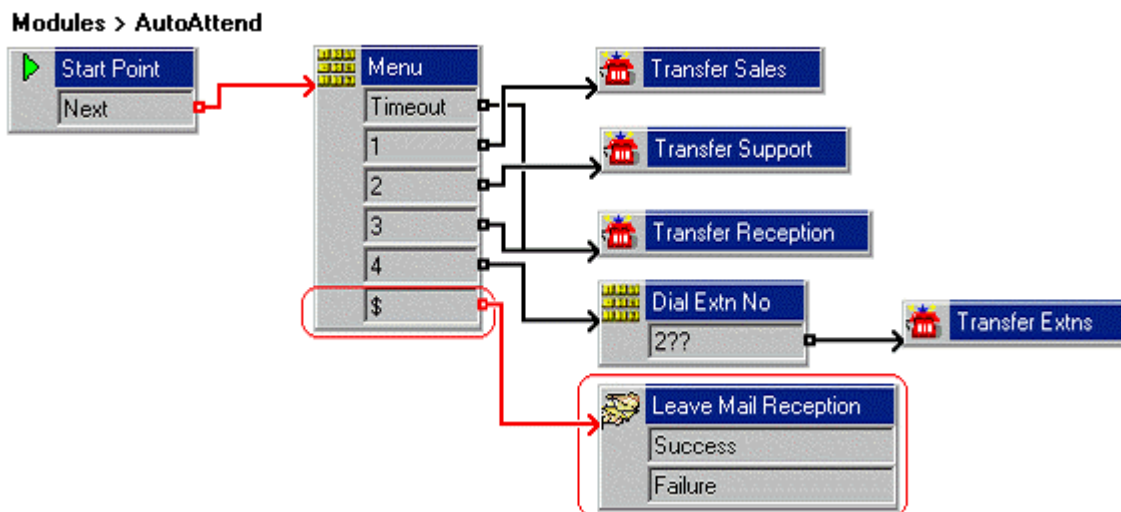

A \$ wildcard will match any dialing by a caller that does not match any of our specified key. In this example, the message is left in the group mailbox used for the receptionist extensions.



The following is an image of a completed call flow:



The red arrow or arrows in the call flow are the changes added in this section.

## Procedure

1. Do the following to add a new option to the **Menu**.
  - a. Select the **AutoAttend** module.
  - b. Open **Properties** for the  **Menu** action.
  - c. In the **Touch Tones** tab, click the **+ Add** icon. The Add Touch Tone Sequence window opens.
  - d. Enter **\$** in the **Sequence** box.
  - e. Click **OK** twice.
2. Do the following to add **Leave Mail** action.
  - a. Click the  **Mailbox Actions** icon and select  **Leave Mail**.
  - b. Click the **Details** pane to place the action.
  - c. Open the **Properties** for the new  **Leave Mail** action.
  - d. In the **General** tab, change the **Token Name** to **Leave Mail Reception**.
  - e. In the **Specific** tab, select **Mailbox** and type **Reception**.
3. Click **OK**.
4. Do the following to add a connection:

Click the  **Connection** and connect **\$** to  **Leave Mail Reception**.
5. Click the  **Save & Make Live** icon.
6. Make a test call to the auto-attendant module:
  - a. Dial **\*90**.
  - b. Enter an incorrect number, one that is not in the menu.
  - c. Voicemail waits five seconds for any further digits. After five seconds, it follows the **\$** result connection. You should hear the prompts to leave a message for the **Reception** group.

### Related links

[Adding Additional Features to the Auto-Attendant](#) on page 18

---

## Using the Generic Action

Callers can be given an option to hear a specific message. For example, details about the latest sales offer. You can add a touch-tone to the **AutoAttend** module through this exercise. A looped connection is used to repeat the recording continually.



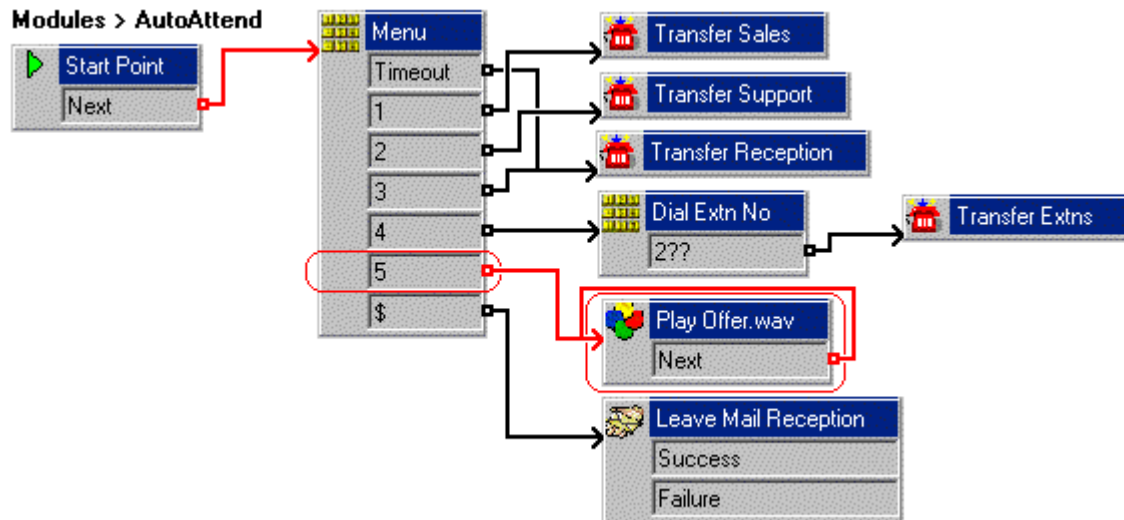



The following is an image of a completed call flow:



The red arrow or arrows in the call flow are the changes added in this section.

## Procedure

1. Do the following to add **Menu** action:
  - a. Select the **AutoAttend** module.
  - b. Open **Properties** for the **Menu** action.
  - c. In the **Touch Tones** tab, select **5**.
  - d. Click **OK**.
2. Do the following to add **Generic** action:
  - a. Click the **Basic Actions** icon and select **Generic**.
  - b. Click the **Details** pane to place the action.
  - c. Open the **Properties** for the new **Generic Action**.
  - d. In the **General** tab, change the **Token Name** to **Play offer.wav**.
3. Do the following to record a message:
  - a. In the **Entry Prompts** tab, select the **+ Add a Prompt** icon. The Wave Editor window opens.
  - b. Click the **Use which media device?** arrow and select **Telephony Handset**.
  - c. In **Extensions**, type the extension number to record from.
  - d. In **Please select a file or enter a new file name**, type `offer.wav`.
  - e. Select **Record**. The telephone corresponding to the extension number entered rings, and you can start to record the prompt.

- f. The latest sales offer message is recorded. For example. *"Latest Avaya offers – 50% discount on all products until the end of the month. Contact your account manager for further information"*.
  - g. Click  **Stop** when you finish the recording.
  - h. Click  **Play** to reply to the recorded message.
  - i. **(Optional)** To re-record the message, select  **Record**.
  - j. When recording is complete, replace the telephone handset.
4. Select **Close** and **OK**.
  5. Do the following to add connections:
    - a. Click  **Connection**.
    - b. Set **5** to the  **Play offer.wav** action.
    - c. Click **Next**.
  6. Select **Close** and **OK**.
  7. Click the  **Save & Make Live** icon.
  8. The auto-attendant greeting needs to be re-recorded to include the new options. For example: *"Welcome to Avaya. Please press 1 for Sales, 2 for Support, 3 for Reception, 4 to dial the extension you want or 5 to hear the latest sales offer. Alternatively hold for further assistance. Thank you."* This can be done using the callflow and short code (\*80) created earlier.
  9. Do the following to test the new announcement:
    - a. To make a test call to the auto-attendant, dial **\*90**.
    - b. Dial **5**. The recording is repeated until the call ends.

#### Related links

[Adding Additional Features to the Auto-Attendant](#) on page 18

---

## Add a Home Action to Restart the Call Flow

Callers to the auto-attendant may want to hear the list of options again. We can do this by adding a  **Home** action which will return them to the start of the callflow.



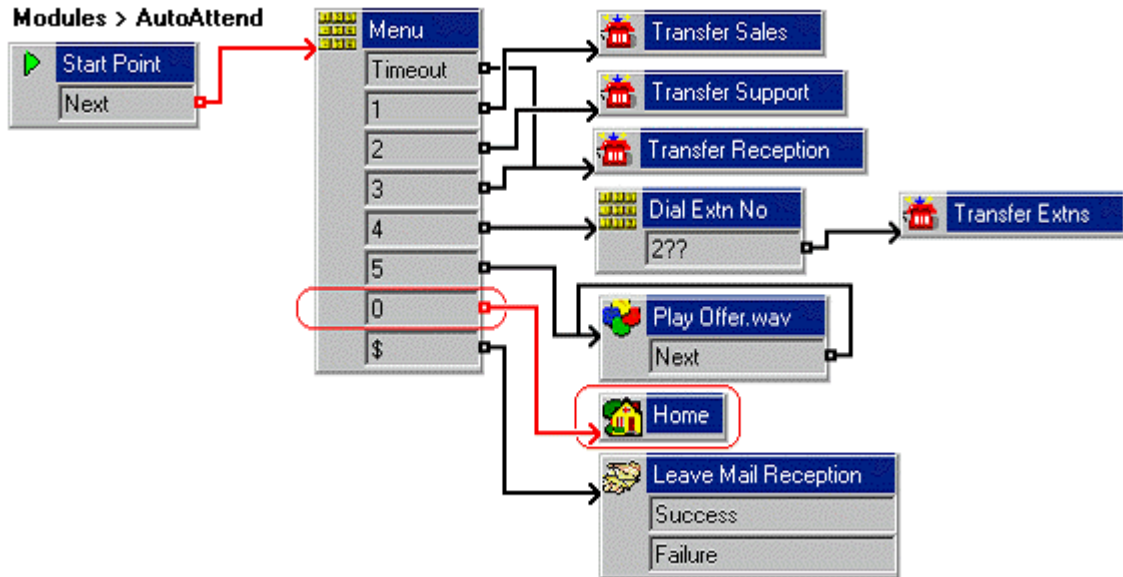



The following is an image of a completed call flow:



The red arrow or arrows in the call flow are the changes added in this section.

## About this task

### Procedure

1. Do the following to add a new option to the **Menu**:
  - a. Select the **AutoAttend** module.
  - b. Open **Properties** for the  **Menu** action.
  - c. In the **Touch Tones** tab, select **0**.
  - d. Click **OK**.
2. Do the following to add a new **Home**:
  - a. Click the  **Basic Actions** icon and select  **Home**.
  - b. Click the **Details** pane to place the action.
3. Do the following to add connections:
  - a. Click  **Connection**.
  - b. Set **0** to the action  **Home**.
4. Select **Close** and **OK**.
5. Click the  **Save & Make Live** icon.
6. The auto-attendant greeting needs to be re-recorded to include the new options. For example: *"Welcome to Avaya. Please press 1 for Sales, 2 for Support, 3 for Reception, 4 to dial the extension you want, or 5 to hear the latest sales offer. Alternatively, hold for further assistance or press 0 to listen to the options again. Thank you."* This can be done using the callflow and short code (\*80) created earlier.

7. Do the following to test the new menu item:
  - a. To make a test call to the auto-attendant module, dial **\*90**.
  - b. Dial **0** to listen to the options again.

**Related links**

[Adding Additional Features to the Auto-Attendant](#) on page 18

# Chapter 5: Collecting Information from a Caller

Rather than answering the call, you may want to let your callers to leave information by answering a set of simple questions. These responses are recorded and saved as a message that can be put into a selected mailbox for processing.

For example, we will let caller's wanting a product catalog, leave their name and address details in response to prompts for those details.

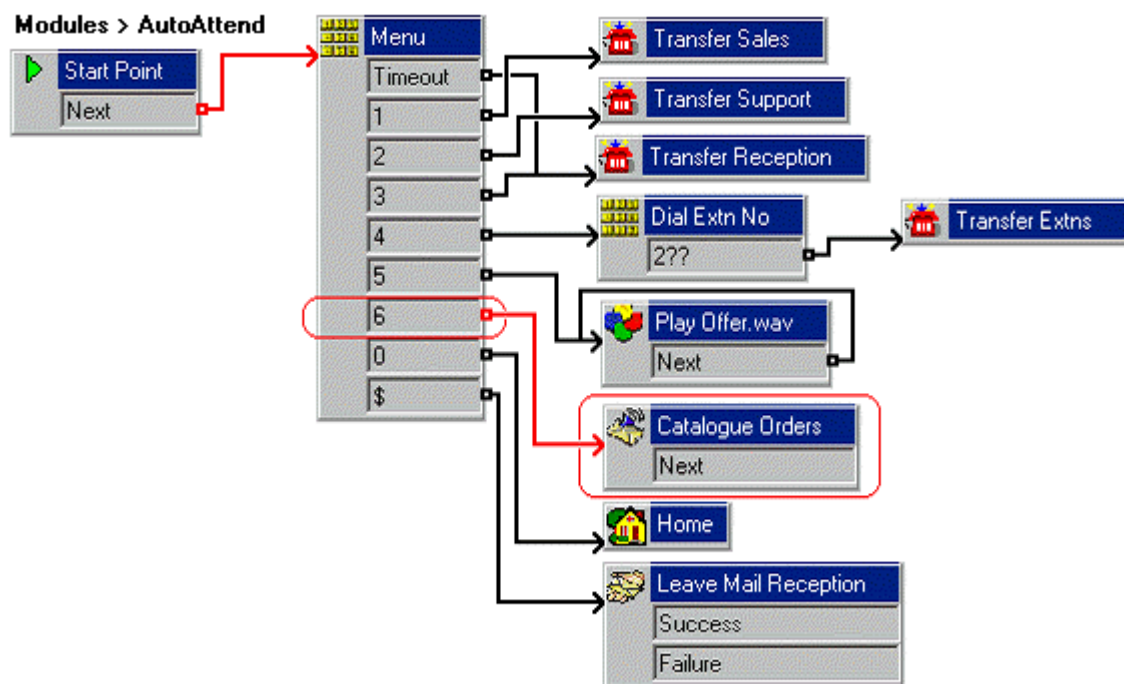

## Related links

[Adding a Voice Question Action](#) on page 27

---

## Adding a Voice Question Action

You can add an option to leave a message in response to pre-recorded prompts. The **Voice Question** action is used to create an interview process. In this example, as a caller, you can

provide the information about where you want a catalog to be sent. Several recordings are made and played in sequence.



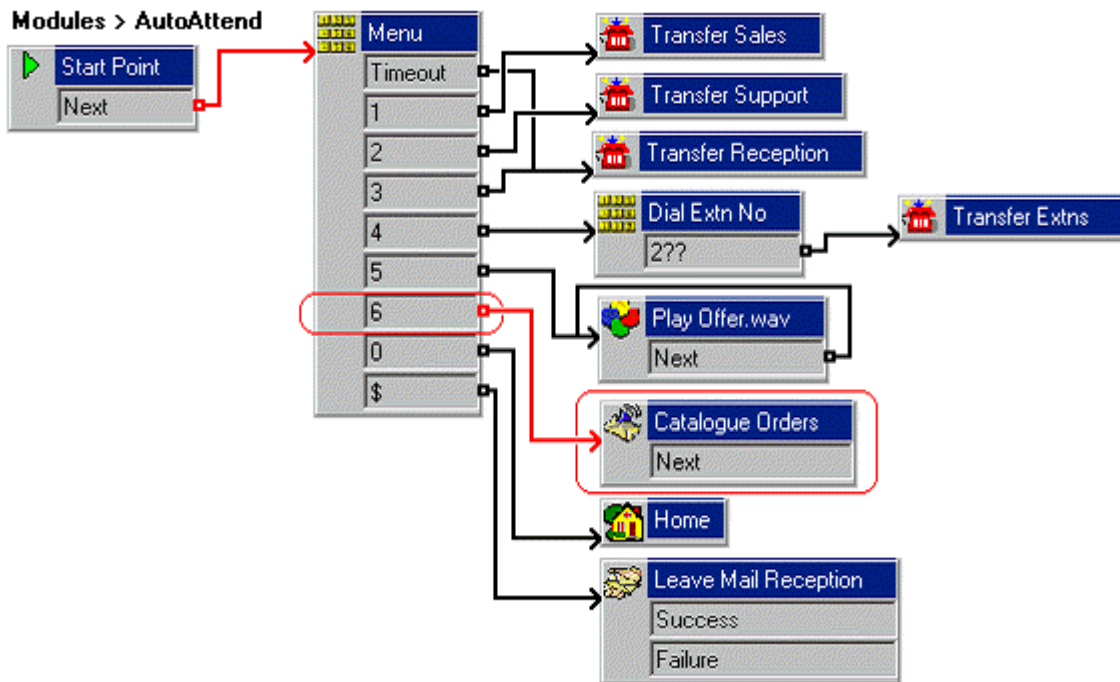





The following is an image of a completed call flow:



The red arrow or arrows in the call flow are the changes added in this section.

## Procedure

1. Do the following to add a new option to the **Menu**:
  - a. Select the **AutoAttend** module.
  - b. Open **Properties** for the **Menu** action.
  - c. In the **Touch Tones** tab, select **6**.
  - d. Click **OK**.
2. Do the following to add a new **Voice Question** action:
  - a. Click the **Mailbox Actions** icon and select **Voice Question**.
  - b. Click the **Details** pane to place the action.
  - c. Open **Properties** for the new **Voice Question** action.
  - d. In the **General** tab, change the **Token Name** to **Catalog Orders**.
3. Do the following to record a message:
  - a. In the **Specific** tab, click **+ Add a Prompt** icon. The Wave Editor window appears.
  - b. Click the **Use which media device?** arrow and select **Telephony Handset**.

- c. In **Extensions**, type the extension number which you want to record.
  - d. In **Please select a file or enter a new file name**, type `catalogue.wav`.
  - e. Select  **Record**. The telephone corresponding to the extension number entered rings, and you can start to record the prompt.
  - f. Click  **Stop** when you finish the recording.
  - g. Click  **Play** to reply to the recorded message.
  - h. Record a message to inform the caller. For example: *"Please follow the instructions to record your name and address and our catalog will be sent to you"*.
  - i. **(Optional)** To re-record the message, select  **Record**.
  - j. When recording is complete, replace the telephone handset.
  - k. Click **Close**.
4. Do the following to add the full name and company name:
    - a. Click the  **Add** icon and record `name.wav`. Record a message asking for full name and company name. For example: *"Please say your full name and company. Press # to continue"*.
    - b. Click **Close**.
    - c. Click the  **Record Response** icon, enter 10.
    - d. Click **OK**.
  5. Do the following to add the delivery address:
    - a. Click the  **Add** icon and record `address.wav`. Record a message asking for a delivery address. For example: *Please say your full address. Press # to continue*.
    - b. Click **Close**.
    - c. Click the  **Record Response** icon, enter 10 and select **OK**.
  6. Do the following to add a thank message:
    - a. Click the  **Add** icon, and record `thanks.wav`. Record a message thanking the caller. For example: *Thank you, your catalog will be sent to the address given*.
    - b. Click **Close**.

7. In the Properties for Catalog Orders window, do the following:
  - a. Select that the sequence of files to be played and recordings are available.

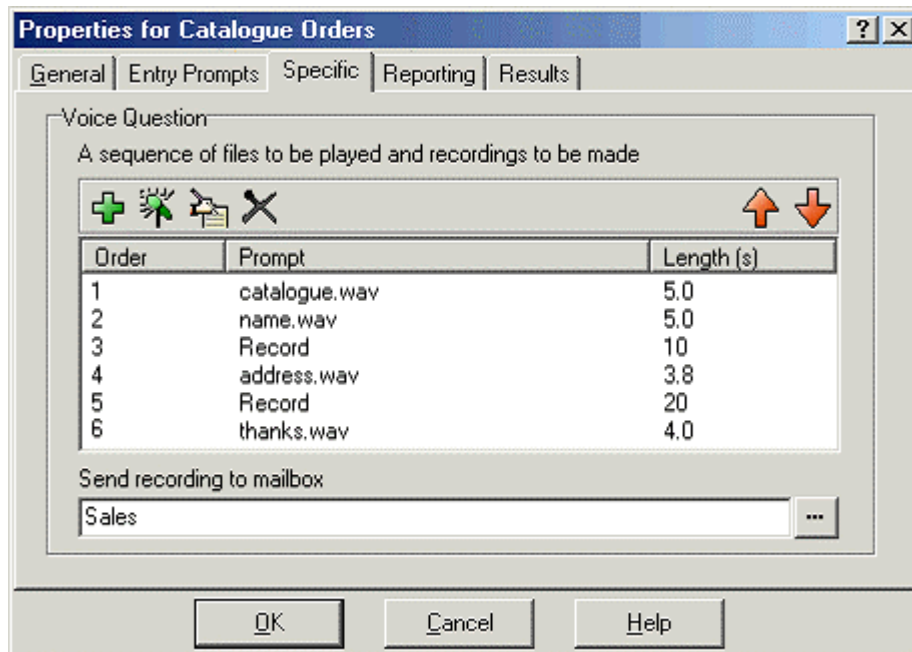

- b. In **Send Recording to Mailbox**, enter `Sales`. Any messages left are stored in the voicemail box for the Sales group.
  - c. Click **OK**.
8. Do the following to add connections:
  - a. Click **Connection**.
  - b. Set **6** to the **Catalog Orders** action.
9. Select **Close** and **OK**.
10. Click the **Save & Make Live** icon.
11. The auto-attendant greeting needs to be re-recorded to include the new options. For example: *"Welcome to Avaya. Please press 1 for Sales, 2 for Support, 3 for Reception, 4 to dial the extension you want, or 5 to hear the latest sales offer. If you require a catalog press 6. Alternatively hold for further assistance or press 0 to listen to the options again. Thank you."* This can be done using the callflow and short code (\*80) created earlier.
12. Do the following to test the new options:
  - a. To make a test call to the auto-attendant, dial **\*90**. You should hear the announcement.
  - b. Dial **6** to access the **Voice Question**. Record your name and address when prompted.

**Related links**

[Collecting Information from a Caller](#) on page 27

# Chapter 6: Collecting Group Messages

In our auto-attendant, we have now provided callers with an option to leave a message containing their name and address details for a product catalog (see [Using a Voice Question Action](#) on page 27). Those details are recorded as a voicemail message sent to the Sales group's mailbox.

However, by default no message waiting indication is sent for hunt group messages. Instead you must decide who should receive message waiting indication for hunt group messages.

Those who receive message waiting indications do not have to be group members. However, non-members can only access the mailbox and collect messages if the mailbox have the mailboxes access code.

## Related links

[Enabling Group Message Waiting Indication](#) on page 32

[Setting a Group Remote Access Code](#) on page 33

---

## Enabling Group Message Waiting Indication

Hunt group message waiting to an individual user is configured by adding the group name to the user's Source Numbers.

### Procedure

1. In IP Office Manager, open the telephone system configuration.
2. Locate the user and double-click the entry to view the user settings.
3. Click the **Source Numbers** tab.
4. Right-click the panel and select **Add**.
5. In **Telephone Number**, type H followed by the group name. For example, in this exercise, type HSales.
6. Click **OK**.

## Related links

[Collecting Group Messages](#) on page 32

---

## Setting a Group Remote Access Code

Users who are group members can access the group mailbox without a mailbox access code configured and set.

For users who are not part of a group but need access to the group mailbox:

- An announcement to the users is made that "Remote access is not configured for this mailbox".
- You need to provide the remote access code to access the mailbox.

### Procedure

1. In IP Office Manager, open the telephone system configuration.
2. To view the user settings, locate the user and double-click the entry.
3. Click the **Voicemail** tab.
4. In **Voicemail Code**, enter a dial-able access code for the mailbox.
5. Enter the same code in **Confirm password**.
6. Click **OK**.

### Related links

[Collecting Group Messages](#) on page 32

# Chapter 7: Using a Whisper Action

In our current example auto-attendant, callers can press 2 to be transferred to the support team. They now want callers to be required to record their name before being transferred. And when transferred, the agent answering the call will hear that name recording.

This can be done by replacing the existing **Transfer** action with **Voice Question** and **Whisper** actions.

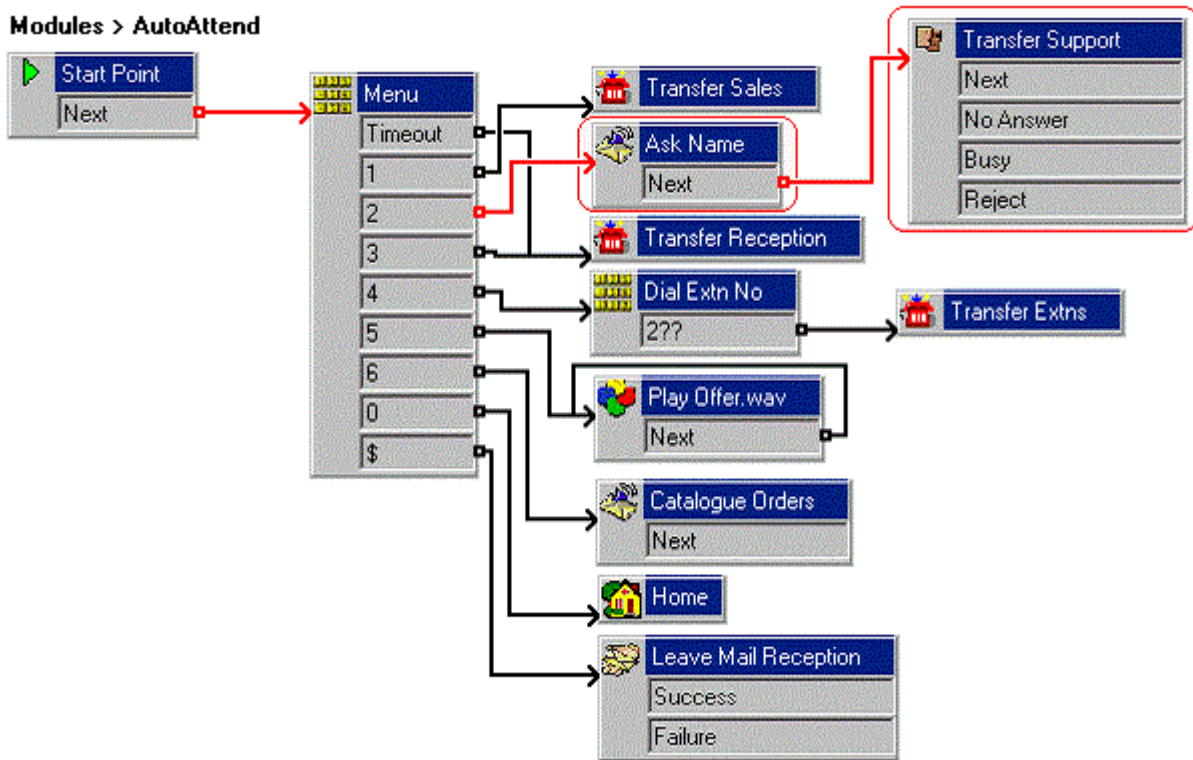

## Related links

[Adding a Whisper Action](#) on page 35

## Adding a Whisper Action



You can record a caller's name using a **Voice Question** action through this exercise. Then using a **Whisper** action, you can pass the recording directly to the **Support** hunt group who answers the call. The hunt group can choose to answer or reject the call.

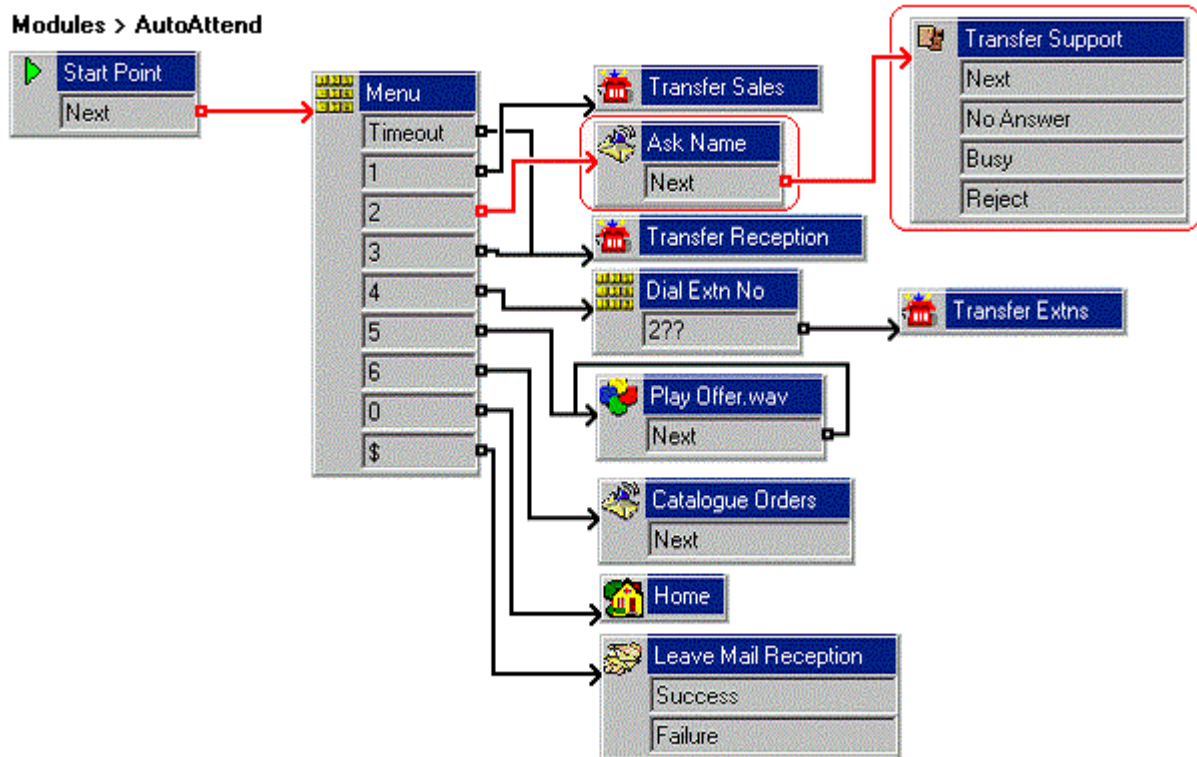





The following is an image of a completed call flow:



The red arrow or arrows in the call flow are the changes added in this section.

### Procedure

1. Do the following to delete the  **Transfer Support**:
  - a. Select the **AutoAttend** module.
  - b. In the **Details** pane, click the  **Transfer Support** action.
  - c. Select **Delete**. The action and corresponding connection to the **Menu** is deleted.
2. Do the following to add a new  **Voice Question**:
  - a. Click **Mailbox Actions** and select **Voice Question**.
  - b. Click the **Details** pane to place the action.
  - c. Open **Properties** for the new **Voice Question** action.
  - d. In the **General** tab, change the **Token Name** to **Ask Token**.

3. Follow the procedure to record the full name and company name in [Adding a Voice Question Action](#) on page 27 exercise.
  - a. In the **Specific** tab, click **+ Add a Prompt** icon. The Wave Editor window opens.
  - b. In **Please select a file or enter a new file name**, click  **Browse**.
  - c. Select **Name.wav** and click **Open**.
  - d. Click **OK**.
4. Do the following to add a **Whisper**:
  - a. Click the  **Telephony Actions** icon and select  **Whisper**.
  - b. Click the **Details** pane to place the action.
  - c. Open **Properties** for the new **Whisper** action.
  - d. In the **General** tab, change the **Token Name** to **Transfer Support**.
  - e. Click **Specific**, in **Play recording to**, type **Support**.
  - f. Click **OK**.
5. Do the following to add connections:
  - a. Click  **Connection**.
  - b. Set **2** to the **Ask Token** action.
  - c. Under **Ask Token**, set  **Whisper**.
6. Click the  **Save & Make Live** icon.
7. Do the following to test the new announcement:
  - a. To make a test call to the auto-attendant, dial **\*90**.
  - b. Dial **2** and record your name and company name when prompted after the tone. You are automatically transferred, the **Support** group.
  - c. Extension 207 rings. Answering the call, you will hear details of the caller's name and company. Then press **1** to accept the call. To reject the call, hang up.

#### Related links

[Using a Whisper Action](#) on page 34

# Chapter 8: Using a Call List Action

You can allow callers to select from a list of users in a group. This is done using a **Call List** action.

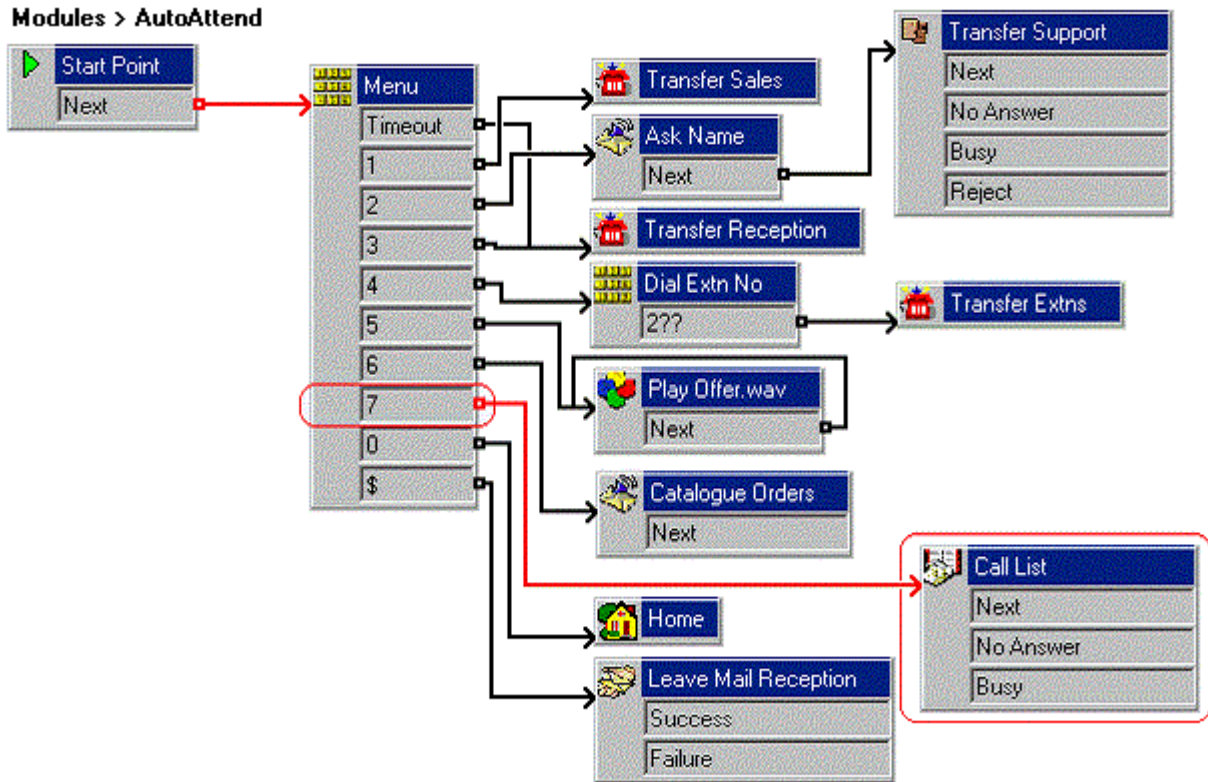

## Related links

[Adding a Call List Action](#) on page 37

---

## Adding a Call List Action



You can add a touch tone to the auto-attendant module to allow callers to select the Accounts group through this exercise. From a given list of extensions, the caller can choose to answer the call.

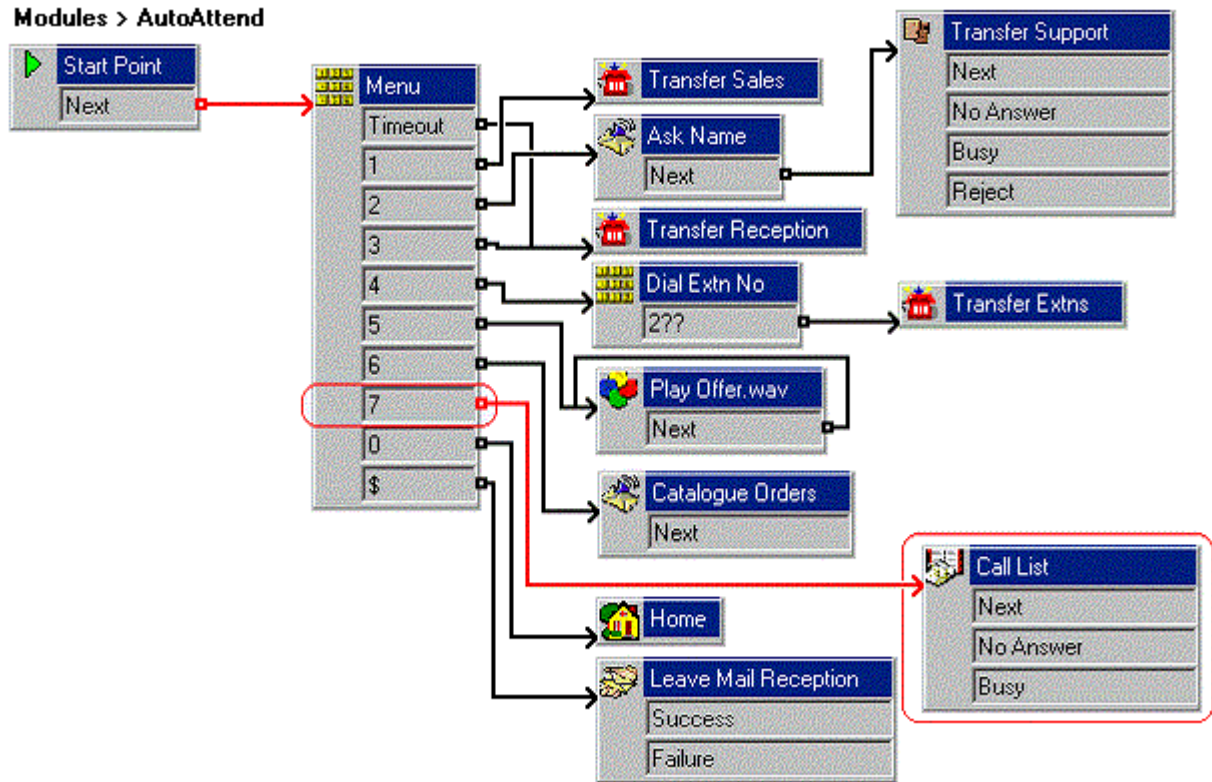

The following is an image of a completed call flow:



The red arrow or arrows in the call flow are the changes added in this section.

## Procedure

1. Do the following to add a new option to the **Menu**:
  - a. Open **Properties** for the  **Menu** action.
  - b. In the **Touch Tones** tab, select 7.
  - c. Click **OK**.
2. Do the following to add a **Call List** action:
  - a. Click the  **Telephony Actions** icon and select  **Call List**.
  - b. Click the **Details** pane to place the action.
  - c. Open **Properties** for the new **Call List** action.
  - d. Click the **Specific** tab.
  - e. In **Transfer to group field**, type `Accounts`.
  - f. Enable the **Prompt user with a list of group members** option.
  - g. Click **OK**.

3. Do the following to add connections:
  - a. Click  **Connection**.
  - b. Set **7** to the  **Call List** action.
4. Select **Close** and **OK**.
5. Click the  **Save & Make Live** icon.
6. The auto-attendant greeting needs to be re-recorded to include the new options. For example: *"Welcome to Avaya. Please press 1 for Sales, 2 for Support, 3 for Reception, 4 to dial an extension, 5 to hear the latest sales offer, 6 if you require a catalog, or 7 for Accounts. To listen to the options again, press 0 or hold for further assistance. Thank you."* This can be done using the callflow and short code (\*80) created earlier.
7. Do the following to test the new announcement:
  - a. To make a test call to the auto-attendant, dial **\*90**.
  - b. Dial **7** to access the **Call List**. A list of extensions in the Accounts group is played. Our Accounts group contains extensions 207 and 208.

#### Related links

[Using a Call List Action](#) on page 37

# Chapter 9: Using the Condition Editor

Currently the example auto-attendant that we have created is being used to answer all external calls 24/7. We now want to enhance it to match the business hours of the company. Outside those hours, callers should be prompted to leave a message.

We will do this using the conditions editor within Voicemail Pro and callflow actions that can test the current status (true or false) of a condition.

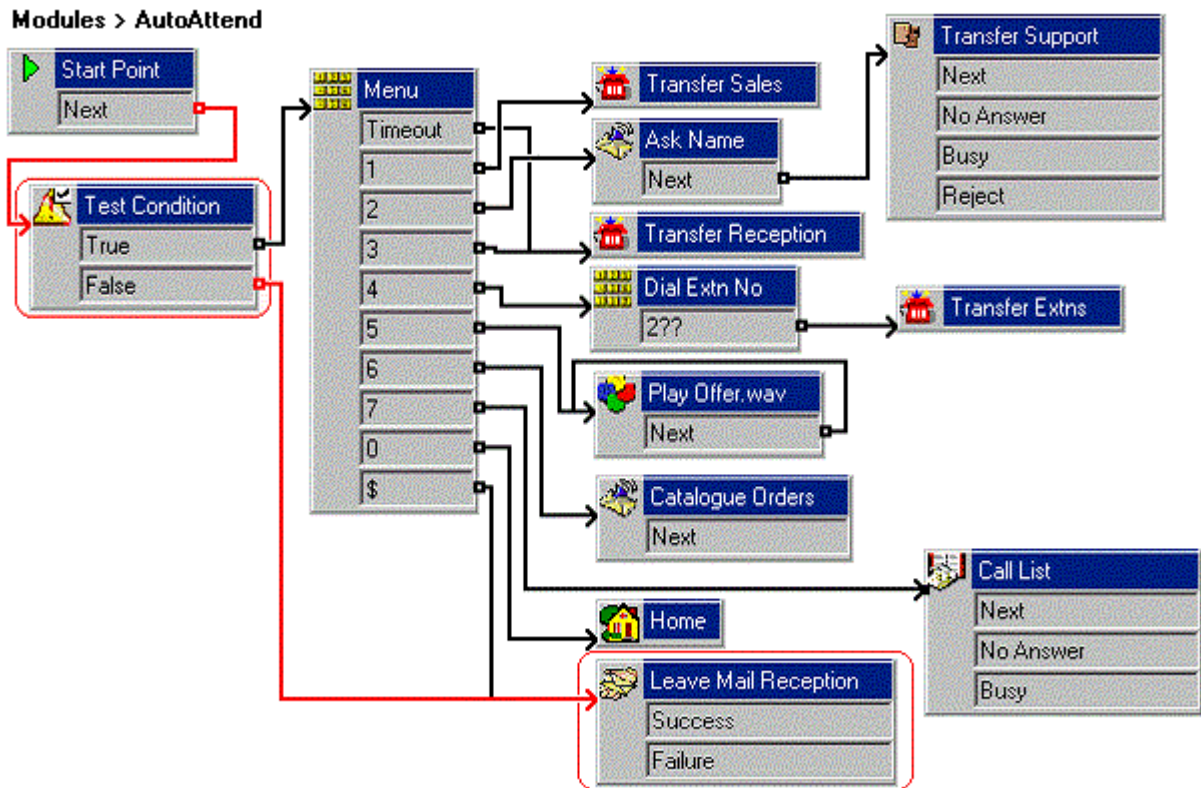

## Related links

[Creating the Attendant Hours Condition](#) on page 41

[Using the Condition](#) on page 41









[Adding the Out of Hours Service](#) on page 43

---

## Creating the Attendant Hours Condition

For our example, we need to create a condition that defines both the companies normal working days and working hours.

### Procedure

1. Click the  **Conditions Editor** icon. The Conditions Editor window opens.
2. Do the following to add a new condition:
  - a. Click the  **New Condition** icon in the toolbar. The New Condition window opens.
  - b. Type `BusinessHours` and click **OK**. The icon  **Attendant** opens in the Condition Editor window.
3. Do the following to set the condition:
  - a. Click the  **Elements** icon.
  - b. Select  **Week Planner**. The icon  **Attendant** appears in the Condition Editor window. The **Week Planner** is added.
  - c. Double-click **Week Planner** to open the available time within a week.
  - d. Select **Monday** to **Friday**. We will leave the start and end times for the days unchanged.
  - e. Click **OK**.
4. Do the following to set the logic setting:
  - a. Click the  **Logic** icon in the toolbar, and select  **OR**.
  - b. Click the condition **Week Planner** in the Condition Editor window. The logic setting is changed to  **OR**.
5. Click **OK**.

### Next steps

- We now need to add an action to the auto-attendant that will test the current value of the condition. Go to [Using the Condition](#) on page 41.

### Related links

[Using the Condition Editor](#) on page 40

---

## Using the Condition

Having created the condition for normal business hours (see [Creating the Attendant Hours Condition](#) on page 41), we need to add a test for it to the auto-attendant.

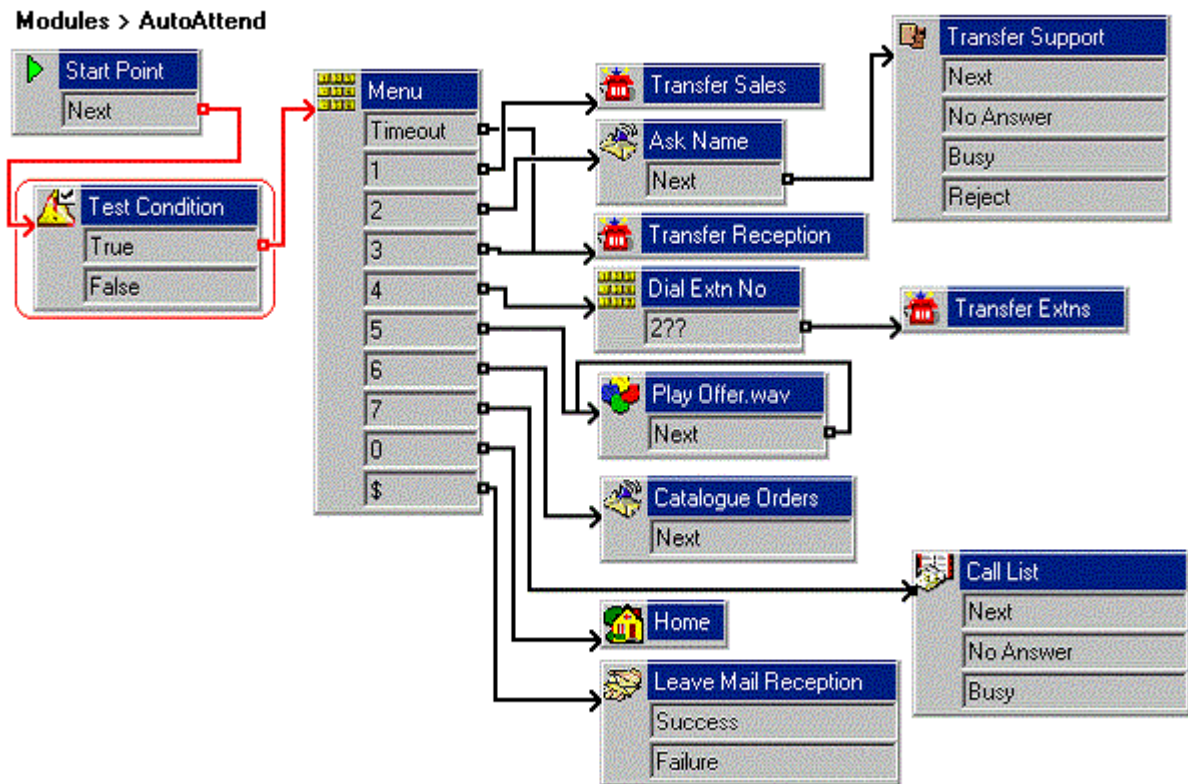

The following is an image of a completed call flow:



The red arrow or arrows in the call flow are the changes added in this section.

## Procedure

1. In the  **AutoAttend** module, delete the existing connection from the **Start Point** to the **Menu** action:
  - a. Select the connection between **Start Point** and **Menu**.
  - b. Press **Delete**.
2. Add a **Test Condition** action:
  - a. Click the **Configuration Actions** icon and select **Test Condition**.
  - b. Click the **Details** pane to place the action.
  - c. Open **Properties** for the new **Test Condition**.
  - d. Click the **Specific** tab.
  - e. Click the **Return the result of the following condition** arrow and select the **BusinessHours** condition.
  - f. Click **OK**.

3. Connect the new action into the callflow:
  - a. Click  **Connection**.
  - b. Click **Start Point** and click **Test Condition** action.
  - c. Select the actions **True** result and connect it to the **Menu** action.
4. Click the  **Save & Make Live** icon.
5. The attendant menu is now only available between 09:00 and 18:00, Monday to Friday.

### Related links

[Using the Condition Editor](#) on page 40

## Adding the Out of Hours Service

Having added the condition test for when the auto-attendant menu should be available, we need to add an action that should be applied to calls outside those times. Otherwise, calls will just be disconnected.





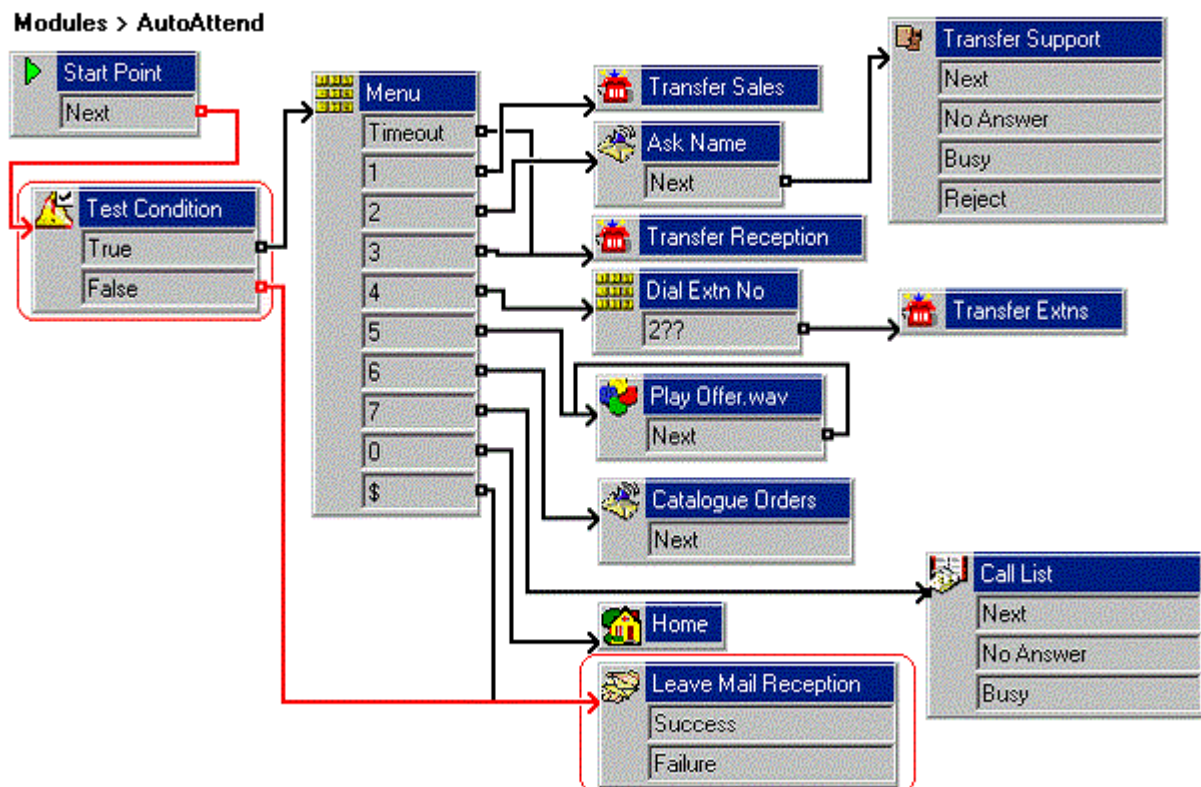

For our example, we will allow caller's outside business hours to leave a message.

The following is an image of a completed call flow:



The red arrow or arrows in the call flow are the changes added in this section.

## Procedure

1. Do the following to transfer the calls during out of hours to reception voicemail:
  - a. Click  **Connection**.
  - b. Connect to **False** under the **Test Condition** action to the **Leave Mail Reception** action.
2. Do the following to test the out-of-hours call route by changing **AutoAttend** to **End time**:
  - a. Click the  **Conditions Editor** icon.
  - b. In the **Attendant** condition, double-click  **Week Planner**.
  - c. For the current day, change the **End time** to a time already past.
  - d. Click **OK**.
3. Click the  **Save & Make Live** icon.
4. Do the following to test the condition:
  - a. To test the new announcement, dial \*90 and make a test call to the auto-attendant.
  - b. When prompted to leave a message, end the call.
5. Do the following to change the **End time** back to 18:00:
  - a. Click the  **Conditions Editor** icon.
  - b. In the **Attendant** condition, double-click  **Week Planner**.
  - c. For the current day, change the **End time** to 18:00.
  - d. Click **OK**.
6. Click the  **Save & Make Live** icon.

## Related links

[Using the Condition Editor](#) on page 40

# Chapter 10: Using User Defined Variables

Previously we have added a condition that alters the callflow automatically based on the company's normal business hours. Now we will use a variable that we can change whenever we want to change how calls are treated.

The value of the variable can be set and changed by calling into another callflow.

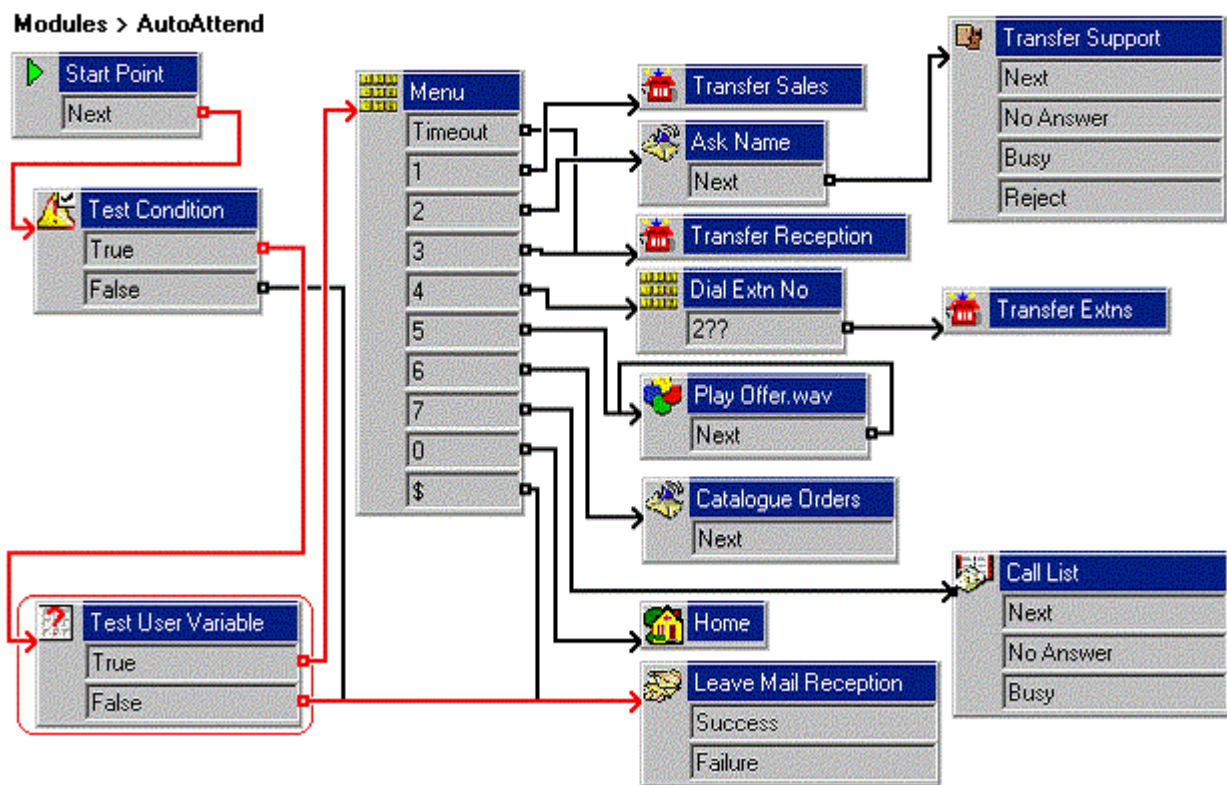

## Related links



- [Creating a New Variable](#) on page 46
- [Creating Modules to Alter the Variables Value](#) on page 46
- [Adding Short Codes to Change the Variable Value](#) on page 47
- [Using the Variable in the Call Flow](#) on page 48
- [Combining the Controls](#) on page 49

---

## Creating a New Variable

We need to tell the voicemail server the name of the new variable.

### Procedure

1. Click the  **User Defined Variable** icon. The User defined variables window opens.
2. Click the  add icon. The Add user defined variable window opens.
3. Enter **Reception** and click **OK**. The variable **Reception** is added in the User defined variables window.
4. Select **Update**. The User defined variables window closes.

### Next steps

- We can now create modules to set the value of the variable. Go to [Creating Modules to Alter the Variables Value](#) on page 46.

### Related links

[Using User Defined Variables](#) on page 45

---

## Creating Modules to Alter the Variables Value





In this example, we will create two new modules.

- One for setting the value of the **Reception** variable's value to `open`.
- The other for setting the value of the **Reception** variable's value to `closed`.

The following is an image of a completed call flow:



### Procedure

1. Click  **Modules** and add a module called **ReceptionOpen**.
2. Add a **Set User Variable** action to the module.
  - a. Click **Conditions Actions**, click  **Set User Variable** action.
  - b. Click the **Details** pane to place the action.
  - c. Open **Properties** for the new  **Set User Variable** action.
  - d. In the **Entry Prompts** tab, click  **Add a Prompt** icon. Add a prompt such as "Reception is open."

- e. Click the **Specific** tab.
  - f. Click **Assign the following user variable** to select **Reception**.
  - g. In the **with the following value** field, type `open`.
  - h. Click **OK**.
3. Connect the **Start Point** to the **Set User Variable** action.
  4. Repeat the steps above to create another module called **ReceptionClosed**. Use it to set the value of the **Reception** variable to `closed` with a prompt such as *Reception is closed*.
  5. Click the  **Save & Make Live** icon.

### Next steps

- Having adding the modules, we can now add short codes to trigger them. Go to [Adding Short Codes to Change the Variable Value](#) on page 47.

### Related links

[Using User Defined Variables](#) on page 45

---

## Adding Short Codes to Change the Variable Value

Having created two modules to change the value of the **Reception** variable between `open` and `closed` (see [Creating Modules to Alter the Variables Value](#) on page 46), we need short codes to trigger either action.

### Procedure

1. In IP Office Manager, add the following short code:
  - a. In **Code**, enter `*91`.
  - b. In **Feature** enter `Voicemail Collect`.
  - c. In **Telephone Number** enter `ReceptionOpen`.
  - d. In **Line Group ID** enter `0`.
2. Repeat the process, this time creating a **\*92** short code set to **ReceptionClosed**.
3. Merge the new short codes with the telephone system.

### Next steps

- We now have modules to set the current value of a variable and short codes to trigger those modules. We can now alter our auto-attendant to use the variable value. Go to [Using the Variable in the Call Flow](#) on page 48.

### Related links

[Using User Defined Variables](#) on page 45

## Using the Variable in the Call Flow

Having defined a user variable (see [Creating a New Variable](#) on page 46), we now also have modules to set the current value of a variable and short codes to trigger those modules. We can now use its current value to control operation of our auto-attendant.



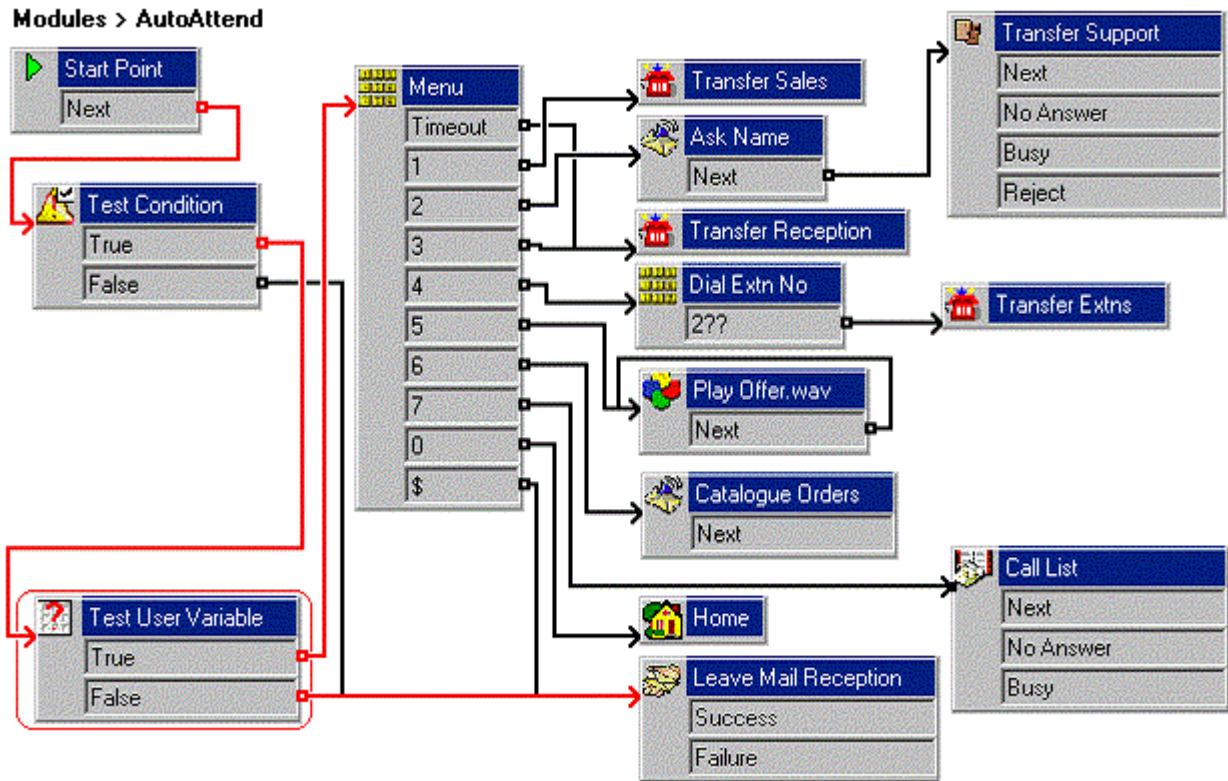

The following is an image of a completed call flow:



The red arrow or arrows in the call flow are the changes added in this section.

### Procedure

1. In the **AutoAttend** module, delete the current connection from the **Test Condition** action's **True** result..
2. Add a **Test User Variable** action.
  - a. Click **Conditions Actions**, select **Test User Variable**.
  - b. Click the **Details** pane to place the action.
  - c. Open the **Properties** for the new **Test User Variable**.
  - d. In the **Specific** tab, from the **This action will return TRUE if the following variable** list box, select **Reception**.
  - e. In **matches the value below**, type `open`.

- f. Click **OK**.
3. Connect the new action into the callflow:
  - a. Click  **Connection**.
  - b. Connect the **Test Condition** action's `True` result to the **Test User Variable** action.
  - c. Connect the  **Test User Variable** action's `True` result to the **Menu** action.
  - d. Connect the  **Test User Variable** action's `False` result to the **Leave Mail Reception** action.
4. Click the  **Save & Make Live** icon.
5. From any extension, dial **\*91** to set the reception variable to **Open**.
6. Make a test call to the auto-attendant module. The `attendant.wav` is played.
7. From any extension, dial **\*92** to set the reception variable to **Close**.
8. Make a test call to the auto-attendant module. A message *Leave a message for reception* is played.
9. From any extension, dial **\*91** to return the reception variable to **Open**.

#### Related links

[Using User Defined Variables](#) on page 45

## Combining the Controls

Previously, we created two modules to control setting the value of our user variable (see [Creating Modules to Alter the Variables Value](#) on page 46). However, we could have combined the actions into a single module, accessed using a single short code.

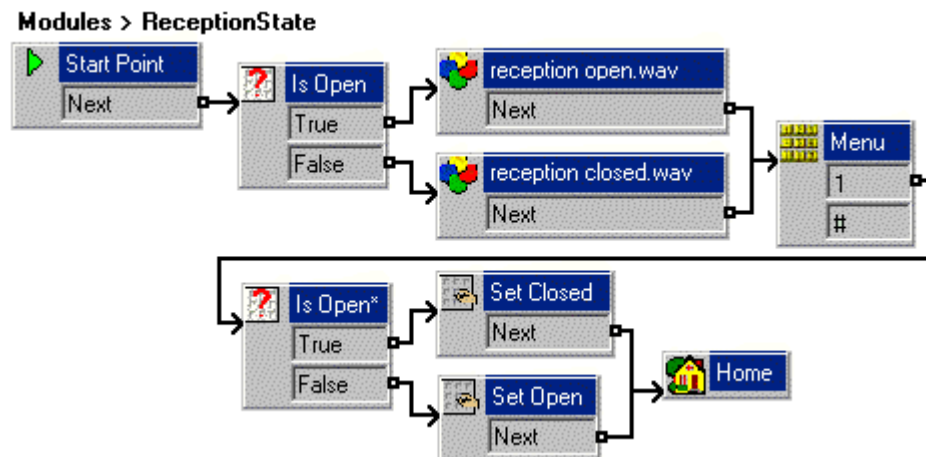

Using User Defined Variables

**Related links**

[Using User Defined Variables](#) on page 45

# Chapter 11: Module Returns and Reusing Modules

So far for our example we have been creating our auto-attendant as a single module. However, you can use an existing module as a component in another modules or callflow. Do so:

- Simplifies the appearance and management of the callflow easier to understand.
- Allows a common action, such as testing for business hours and whether the reception is open, to be used by multiple other modules.

For our example, we will combine the auto-attendants **Test Condition** and **Test User Variable** actions into a separate module.

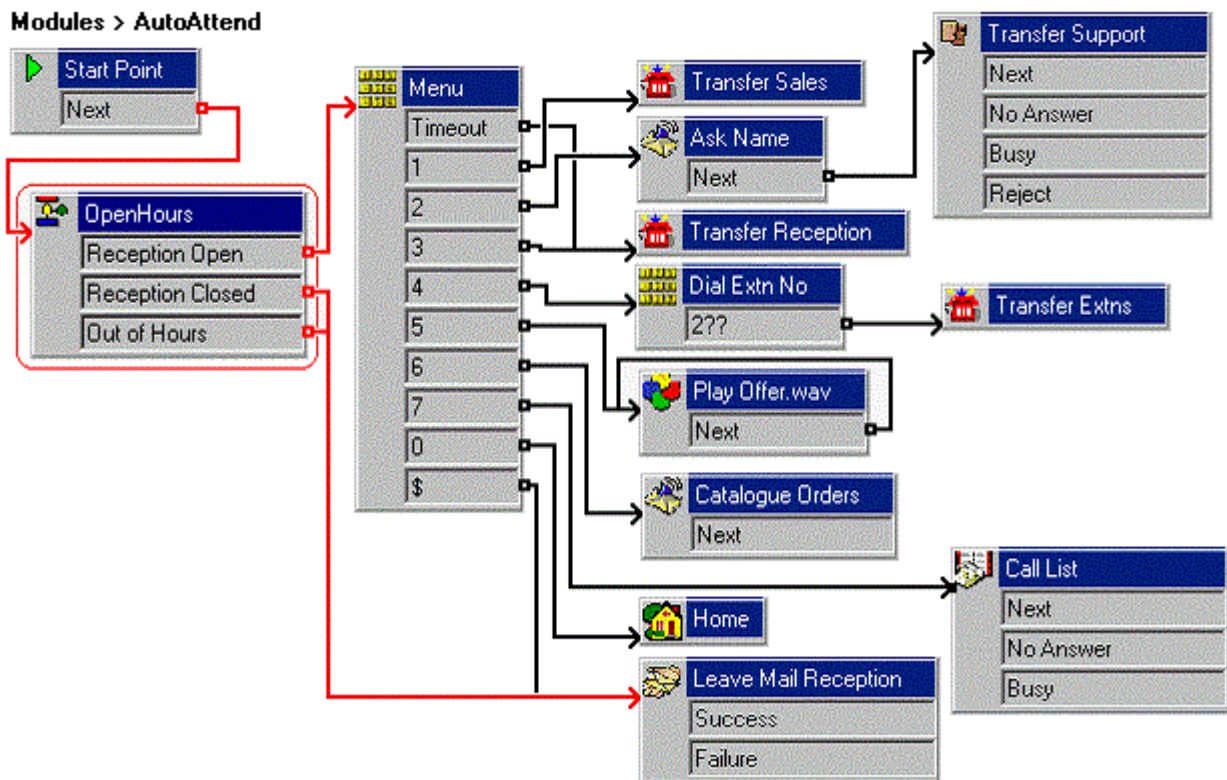

Modules > OpenHours

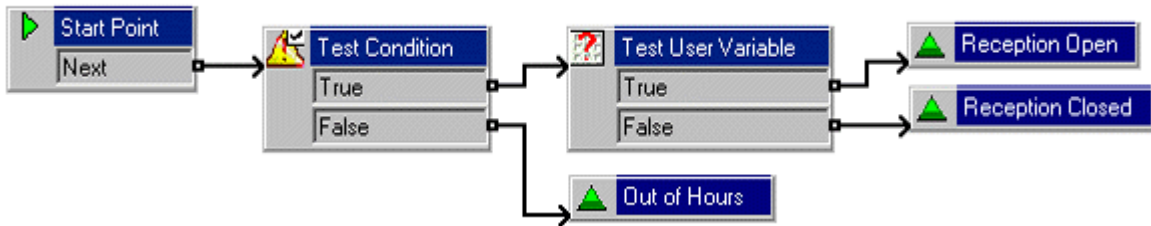

Related links

[Creating the Module for Reuse](#) on page 52

[Adding the Module](#) on page 53

---

## Creating the Module for Reuse

In this example we will create a module that combines the **Test Condition** and **Test User Variable** actions previously added directly to the auto-attendant module. The new module will contain a number of **Module Return** actions. When the module is used in another callflow, these appear as connection results in that callflow.





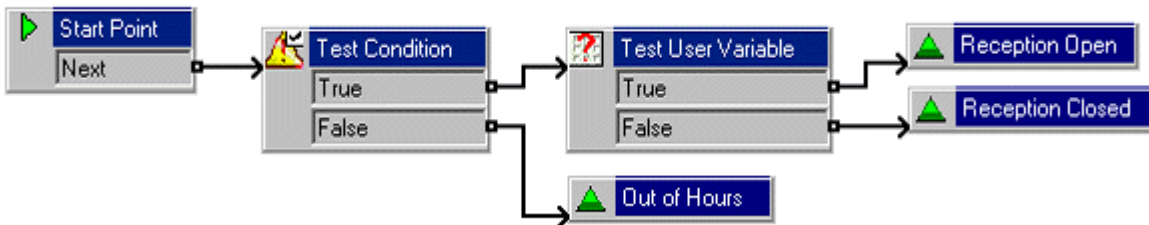



The following is an image of a completed call flow:

Modules > OpenHours



### Procedure

1. Add a new **Modules** called **OpenHours**.
2. Add a **Test Condition** action.
  - a. Click **Conditions Actions**, click **Test Condition**.
  - b. Click the **Details** pane to place the action.
  - c. Open the **Properties** for the new **Test Condition**.
  - d. In the **Specific** tab, click the list box, select the `Attendant` condition.
  - e. Click **OK**.
3. Add a **Test User Variable** action.
  - a. Click **Conditions Actions**, select  **Test User Variable**.

- b. Click the **Details** pane to place the action.
  - c. Open the **Properties** for the new  **Test User Variable**.
  - d. In the **Specific** tab, from the **This action will return TRUE if the following variable** list box, select **Reception**.
  - e. In **matches the value below**, type `open`.
  - f. Click **OK**.
4. Do the following to add three-module return actions.
    - a. Click  **Basic Actions**, click  **Module Return**.
    - b. Click the **Details** pane to place the action.
    - c. Right-click the new  **Module Return**, select **Rename**. The New action name window opens. Type `Reception Open`.
    - d. Click **OK**.
    - e. Add a  **Module Return** and rename it `Reception Closed`.
    - f. Add a  **Module Return** and rename it `Out of Hours`.
  5. Do the following to add a connection.
    - a. Click  **Connection**.
    - b. Connect the **Test Condition** action's `True` result to the **Test User Variable** action.
    - c. Connect its `False` result to the **Module Return** named `Out of Hours`.
    - d. Connect the **Test User Variable** action's `true` result to the **Module Return** named `Reception Open`.
    - e. Connect the **Test User Variable** action's `true` result to the **Module Return** named `Reception Open`.
  6. Click the  **Save & Make Live** icon.

### Next steps

- We can now add the module to our existing auto-attendant module. Go to .

### Related links

[Module Returns and Reusing Modules](#) on page 51

---



## Adding the Module

Having created a module to check whether the business and reception are open (see [Creating the Module for Reuse](#) on page 52), we can now add it to the example auto-attendant.

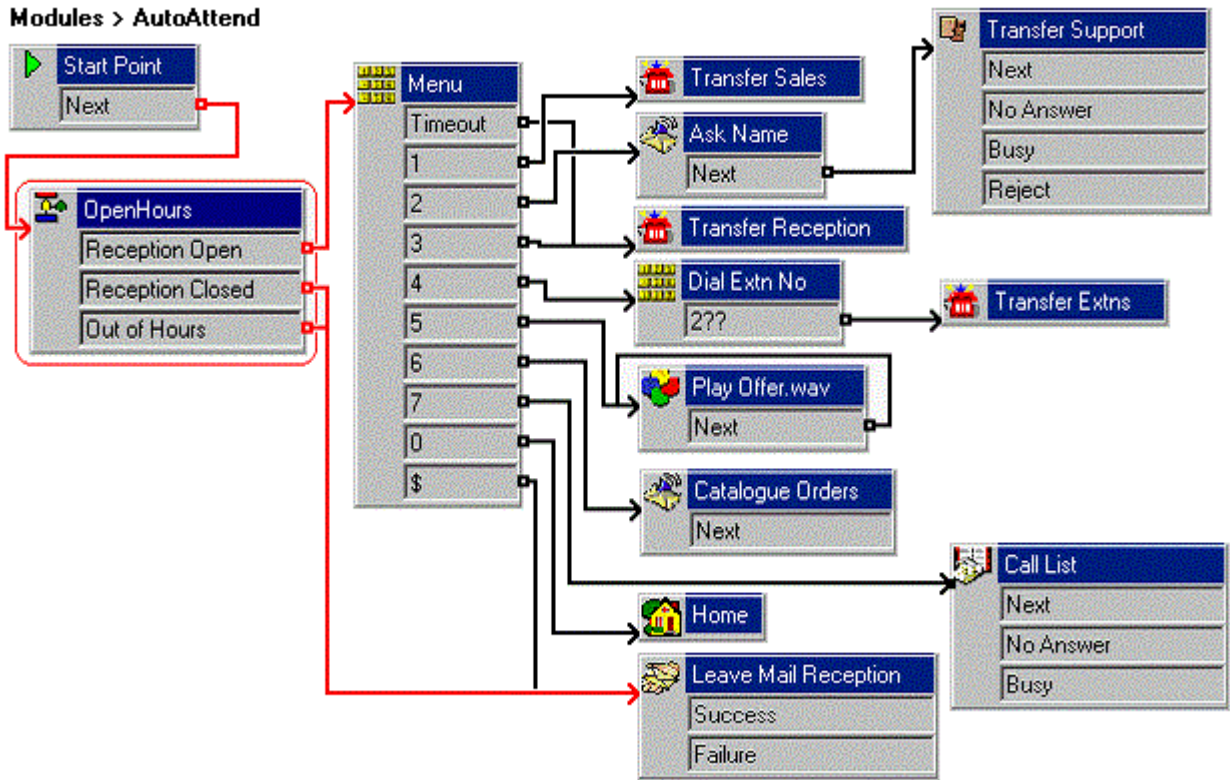
The following is an image of a completed call flow:



### Procedure

1. In **Voicemail**, open the **AutoAttend** module.
2. Delete the existing **Test Condition** and **Test User Variable** actions.
3. Click and drag **OpenHours** module from the list of modules into the **AutoAttend** module.
4. Click  **Connection**.
  - a. Connect the **Start Point** to the **OpenHours** module
  - b. Connect the `Reception Open` result to the **Menu** action.
  - c. Connect the `Reception Closed` and `Out of Hours` results to **Leave Mail Reception**.
5. Click the  **Save & Make Live** icon.

### Related links

[Module Returns and Reusing Modules](#) on page 51

# Part 3: Creating a Hunt Group Callflow

# Chapter 12: Creating a Hunt Group Attendant

Currently, callers leaving a message for the Sales hunt group hear the normal prompts. That behavior can be customized to provide callers with other options before actually leaving a message.

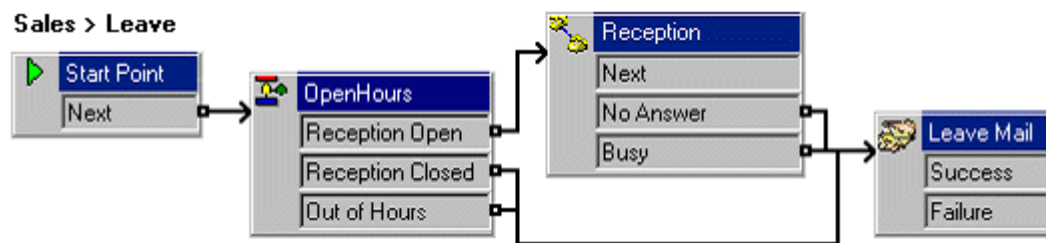

## Related links

[Add the Sales Group Attendant](#) on page 56

---

## Add the Sales Group Attendant

In this exercise we will create a callflow for callers leaving a message for the Sales group. It reuses the same module for business hours are used by the main auto-attendant.

The following is an image of a completed call flow:

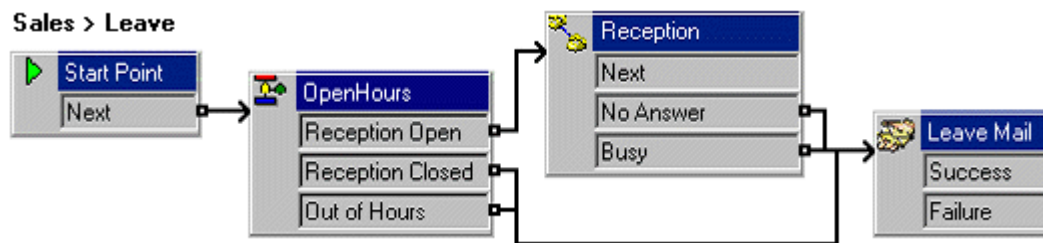

## Procedure

1. Under **Specific Start Points**, right-click **Groups** and select **Add**.
2. Use the drop-down list to select **Sales**.
3. Check **Leave** and then select **OK**.

4. Click the **Leave** start point now under **Sales**.
5. From the list of **Modules**, click and drag **OpenHours** into the call flow.
6. From **Telephony Actions**, add an **Assisted Transfer** and open its properties.
  - a. In the **General** tab, change the **Token Name** to **Reception**.
  - b. In the **Entry Prompts** tab, add a *"Transferring you to reception"* prompt.
  - c. In the **Specific** tab, set the **Mailbox** to **Reception**.
  - d. Set the **Source of transfer** to **Sales Busy** and click **OK**.
7. Connect the modules as shown in the image above.
8. From **Mailbox Actions**, add a **Leave Mail** action and open its properties.

In the **Specific** tab, set the **Mailbox** to **Sales**.
9. Click the  **Save & Make Live** icon.

#### Related links

[Creating a Hunt Group Attendant](#) on page 56

# Chapter 13: Using a Queue Position Action

You can replace the default queued message with the caller position in the Sales group queue through this exercise. You can create a recording method that allows a non-system administrative person (such as a receptionist) to record or re-record messages using short code. Once the system administrator configures, you can record or re-record messages without accessing the GUI, for example, when the entire team is attending an off-site meeting.

## Related links

[Adding a Queued Message](#) on page 58

[Creating the Queued Call Flow](#) on page 59

---

## Adding a Queued Message

Use this procedure to add the .wav file is used to replace the default "You are in a queue" greeting.

### Procedure

1. Add **Edit Play List** action and open its **Properties**.
  - a. Change the **Token Name** to `Edit SalesQueue.wav`.
  - b. In the **Specific** tab, enter `sales queue.wav` in the **File path** and select **OK**.
2. Click **2** to `Edit SalesQueue.wav`.
3. Click the  **Save & Make Live** icon.
4. On an extension, dial **\*80**.
  - a. Dial 1234 when you are requested to enter the access code.
  - b. Record a message, for example, *All members of our Sales team are currently busy. Please hold, you are currently in a position.*

## Related links

[Using a Queue Position Action](#) on page 58

## Creating the Queued Call Flow

You can add a new Queued start point for the Sales group.

The following is an image of a completed call flow:

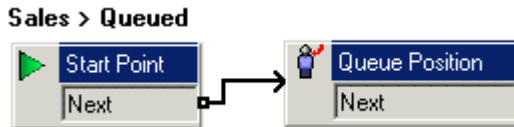

### Procedure

1. Under **Specific Start Points** for **Groups**, right-click **Sales** and select **Edit**.
2. Check **Queued** and choose **OK**.
3. Select the **Queued** start point.
4. From **Queue Actions**, add a **Queue Position** action and open its properties.
  - a. In the **Entry Prompts** tab, add `sales queue.wav` and select **OK**.

**Note:**

You can also click the **Specific** tab to add a prompt after announcing the caller position.

- b. Connect the **Start Point** to the **Queue Position** action.
5. Click the **Save & Make Live** icon.
6. Make extension 208 busy and dial 301 from 207. After 10 seconds, you are placed in the queue, and `sales queued.wav` is played, indicating your position in the queue. If you continue to hold, you eventually hear the queued message, which repeats every 30 seconds.

### Related links

[Using a Queue Position Action](#) on page 58

# Chapter 14: Adding a Queue ETA Action

You can use a **Queue ETA** action on the queued message to inform callers of the waiting time for answering the call through this exercise.

- Calculating the Estimated Time to Answer (ETA): At least five answered calls within the last hour are required to calculate the ETA. If more calls are available, the ETA is calculated from the average of the last 20 answered calls within the previous 60 minutes.

## Related links

[Add an ETA Message](#) on page 60

[Adding the Queue ETA Action](#) on page 61

---

## Add an ETA Message

You can add the `.wav` file that is used to inform callers of their estimated time of answer.

### Procedure

1. In the **Recording** module, add touch-tone **3** to the **Menu** action.
2. Add **Edit Play List** action and open its **Properties**.
  - a. Change the **Token Name** to `Edit AnsweredIn.wav`.
  - b. In the **Specific** tab, enter `answered in.wav` in the **File path** and select **OK**.
3. Connect **3** to `Edit AnsweredIn.wav`.
4. Click the  **Save & Make Live** icon.
5. Using the short code `*80`, record a message, for example, *...and will be answered in the following number of minutes*.

## Related links

[Adding a Queue ETA Action](#) on page 60

## Adding the Queue ETA Action

The following is an image of a completed call flow:



### Procedure

1. Select the **Queued** start point under the **Sales** group.
2. From **Queue Actions**, add a **Queue ETA** action and open its properties.
3. Connect the **Queue Position** action to the **Queue ETA** action.
4. Click the **Save & Make Live** icon.
5. Make extension 208 busy and dial 301 from 207. When you are placed in the queue, `sales_queue.wav` plays and your position in the queue. Later when you are placed in the queue, `time.wav` plays and estimated time to answer.

### Related links

[Adding a Queue ETA Action](#) on page 60

# Chapter 15: Still Queued

After hearing the queued call flow, callers in the queue hear queued messages. You can customize the queued actions to allow those queued callers to exit the queue and leave a message or be transferred to the **Reception** group through this exercise.

## Related links

[Recording a Sales Still Queued Message](#) on page 62

[Adding the Still Queued Actions](#) on page 62

---

## Recording a Sales Still Queued Message

You can add the `wav` file that is used to replace the default "You are still in a Queue" greeting.

### Procedure

1. In the **Recording** start point, add a new touch-tone and **Edit Play List** action through which you can record `sales still queued.wav`.
2. Using the short code `*80`, record a message. For example, *All our Sales team are currently busy. Press 1 to remain in the queue, otherwise please hold.*

## Related links

[Still Queued](#) on page 62

---

## Adding the Still Queued Actions



You can add a **Still Queued** start point for the **Sales** hunt group.

The following is an image of a completed call flow:

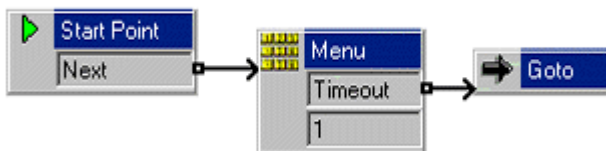
Sales > Still Queued



## Procedure

1. Under  **Groups**, right-click **Sales** and select **Edit**.
2. Add **Still Queued** to the selected options and click **OK**.
3. Select the **Still Queued** start point under **Sales**.
4. Add a new **Menu** action and open its **Properties**.
  - a. In the **Entry Prompts** tab, add `sales still queued.wav`.
  - b. In the **Touch Tones** tab, tick **1**.
  - c. Set **Wait for a key press for up to** to **3** and select **OK**.
5. From **Basic Actions**, add a **Goto** action and open its properties.
  - a. In the **Specific** tab, click **Browse**.
  - b. Select **Start Point** or module, and from the list, select **Sales Leave**.
6. Do the following to add a connection:
  - a. Click  **Connection**.
  - b. Click **Start Point** and select **Menu**.
  - c. Connect the **Timeout** result to the **Goto** action.
7. Click the  **Save & Make Live** icon.
8. Do the following to make a test call that is queued.
  - a. Make 208 busy and dial 301 from 207. You will hear to a message, for example *You are placed in a queue* and the default queued greeting is played with your queue position and estimated time answer.
  - b. Wait for another 20 seconds. The call flows to **Still Queued** start point.
  - c. Press 1 to stay in the queue. Wait, and on the second turn, do not press 1. The call is transferred to the actions in the **Sales Leave** call flow.

## Related links

[Still Queued](#) on page 62

# Chapter 16: Forwarding Messages to Multiple Users

You can learn how to create a module that allows the users to record an announcement is automatically forwarded to several mailboxes.

## Related links

[Creating the Module to Record and Forward the Message](#) on page 64

[Adding a short code](#) on page 65

---

## Creating the Module to Record and Forward the Message

You can add the **Start Point** that records and forwards the message.

The following is an image of a completed call flow:



## Procedure

1. Add a new **Modules** called **Sales Team**.
2. Add an **Edit Play List** action and open its properties.
  - a. Change the **Token Name** to **Record Sales Message**.
  - b. In the **Specific** tab, enter `sales msg.wav` and select **OK**.
3. Add a new **Generic Action** and open its properties.

In the **Specific** tab, enter `FWD:207#208##`, and select **OK**.
4. Connect the **Start Point** and **Record Sales Message**.
5. Connect the **Record Sales Message** and **Generic** actions.
6. Click the  **Save & Make Live** icon.

## Related links

[Forwarding Messages to Multiple Users](#) on page 64

---

## Adding a short code

Use this procedure to add short codes to access the **Sales Team** module.

### Procedure

1. In IP Office Manager, add the following short codes:
  - a. In **Code**, enter \*95.
  - b. In **Feature**, enter `Voicemail Collect`.
  - c. In **Telephone Number**, enter `Sales Team`.
  - d. In **Line Group ID**, enter 0.
  - e. Leave **Locale** and **Force Account Code** blank.
2. Save and merge the configuration with the telephone system.
3. On extension 205, dial \*95 and record a message. For example, *Sales meeting on Monday at 9.30 am in the Board Room*. Extensions 207 and 208 announces the Sales Team message.

### Related links

[Forwarding Messages to Multiple Users](#) on page 64

# Part 4: Creating a Personal User Callflow

# Chapter 17: Create an User Auto-Attendant

The callflow used for individual users can be customized in the same way as that of hunt groups and general calls.

## Related links

[Creating a Personal Attendant for a User](#) on page 67

[Using a Default Start Point](#) on page 68

---

## Creating a Personal Attendant for a User

You can add a **User Start Point** for callers leaving a voicemail for Kate Smith (extension 208). To this call flow, you can add a menu of options for callers.

This user **Specific Start Points** action precedes any call flow in the default **Leave** start point and standard voicemail.

The following is an image of a completed call flow:

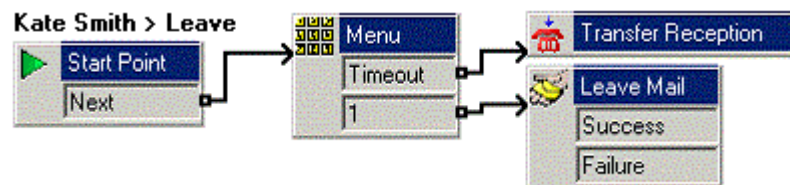

## Procedure

1. Under **Specific Start Points**, right-click **Users** and select **Add**.
2. In the **Name**, enter `Kate Smith`.
3. Select the **Leave** entry point and click **OK**.
4. Click **Leave** now shown under Kate Smith.
5. Create a recording for the **Menu** action.

Create a recording and a call flow that allows a caller to choose whether to leave a message, transfer to Bob Rogers (207), transfer to the Sales group (301), or hold to be transferred to Reception (300).

**\* Note:**

You cannot use the usual mailbox greeting, as the **Leave Mail** action uses that action.

6. Click the  **Save & Make Live** icon.

### Result

From an extension other than 207 or 208, dialing 208, after not being answered the call announcement is heard as per the recording in **Menu** action and the call is transferred to Kate Smiths voicemail.

### Related links

[Create an User Auto-Attendant](#) on page 67

---

## Using a Default Start Point

Through this exercise can use the **Default Start Points > Collect** to change the options available to all users when they collect their messages.

A specific start point for a specific user or group precedes a default start point.

The following is an image of a completed call flow:

**Default Start Points > Collect**

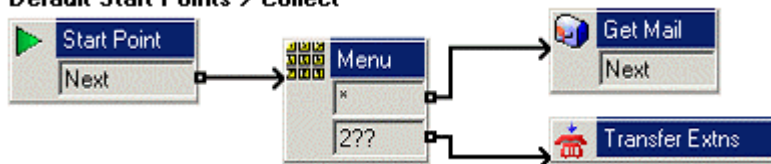

### Procedure

1. In **Default Start Points**, select **Collect**.
2. Add a **Menu** action and in its **Touch Tones** tab, add \* and 2??.
3. From **Mailbox Actions**, add a **Get Mail** action and open its properties.  
In the **Specific** tab, ensure the **Caller's Mailbox** option is selected.
4. Add a **Transfer** action and open its properties.
  - a. Change its **Token Name** to **Transfer Extn.**
  - b. In the **Specific** tab, enter \$KEY in the **Mailbox** action.
5. Do the following to add a connection:
  - a. Click  **Connection**.
  - b. Click **Start Point** and click **Menu** action.
  - c. Click \* for the call flow to **Get Mail** action.

- d. Click **???** for the call flow to **Transfer Extn** action.
6. Add a `wav` file of the options to the **Entry Prompts** of the **Menu** action.
7. Click the  **Save & Make Live** icon.
8. At any extension, dial \*17 and test that the new start point is operational.

**Related links**

[Create an User Auto-Attendant](#) on page 67

# Chapter 18: Using an Assisted Transfer Action

You can replace the **Transfer** action with an **Assisted Transfer** action. This new action returns the user to the **Menu** action if the called party is busy or does not answer. Therefore, the user can make another choice if required.

## Related links

[Adding the Assisted Transfer Action](#) on page 70

[Adding a Number Unavailable Prompt](#) on page 71

---

## Adding the Assisted Transfer Action

The following is an image of a completed call flow:

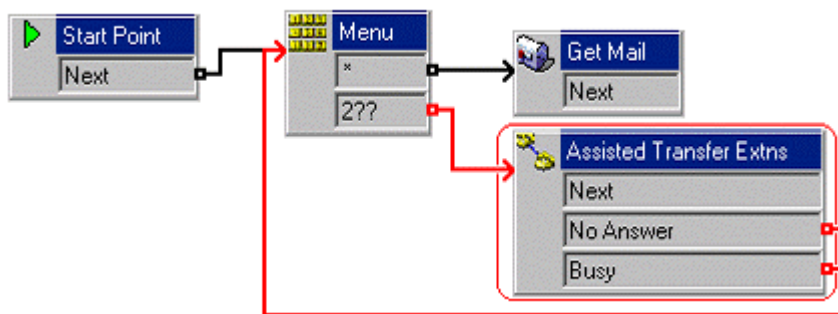

### Default Start Points > Collect



The red arrow or arrows in the call flow are the changes added in this section.

## Procedure

1. Within **Default Start Points > Collect**, delete the **Transfer Extn** action.
2. From **Telephony Actions**, add an **Assisted Transfer** action and open its properties.
3. Change **Token Name** to **Assisted Transfer Extns**.
  - a. In the **Specific** tab, in **Mailbox**, enter `$KEY`.
  - b. Change **No Answer Timeout** to 10 seconds, and select **OK**.

4. Do the following to add a connection:
  - a. Click  **Connection**.
  - b. Click **2??** for the call flow to the **Assisted Transfer Extns** action.
  - c. Click **No Answer** or **Busy** for the call flow to the **Menu**.
5. Click the  **Save & Make Live** icon.
6. Do the following to test call flow:
  - a. Make 208 busy. At another extension, dial \*17. Dial 208 when prompted.
  - b. As 208 is busy, you are returned to the **Menu** action.
  - c. Dial another extension that you know is free. Allow this extension to ring for 10 seconds, and you are returned to the **Menu** action again.

### Related links

[Using an Assisted Transfer Action](#) on page 70

## Adding a Number Unavailable Prompt

You can use the **Home** action to simplify the connections in the call flow and play a wav file to users when an extension they want is busy or not answered.

The following is an image of a completed call flow:

### Default Start Points > Collect

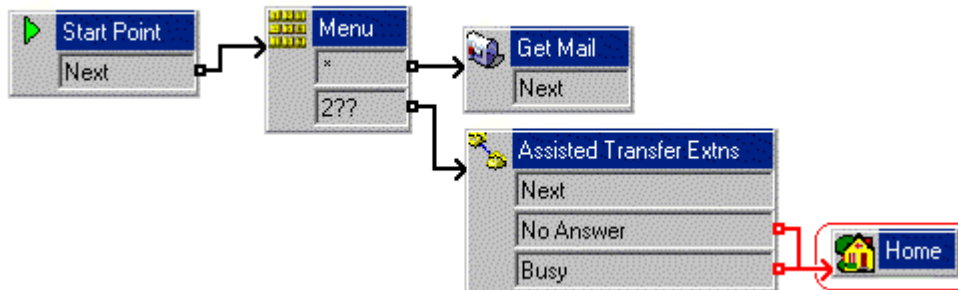

The red arrow or arrows in the call flow are the changes added in this section.

### Procedure

1. In the **Recording** module, add a new touch-tone and using the **Edit Play List** action allows you to record unavailable.wav with a message. For example: "Sorry, that extension is currently unavailable. Please make another choice."
2. In **Default Start Points > Collect**, delete the connections to the **Menu** action from the **No Answer** and **Busy** results.
3. Add a **Home** action and open its properties.

## Using an Assisted Transfer Action

4. In the **Entry Prompts** tab, add `unavailable.wav` file.
5. Click **Close** and then **OK**.
6. Connect the **No Answer** and **Busy** results to the **Home** action.
7. Click the  **Save & Make Live** icon.
8. Do the following to test call flow:
  - a. Make 208 busy.
  - b. On another extension, dial \*17 and dial 208 when prompted. As this extension is busy, you hear `unavailable.wav` and then are returned to the **Menu** action.

### Related links

[Using an Assisted Transfer Action](#) on page 70

# Chapter 19: Using a Play Configuration Menu Action

Internal users can use the voicemail service to alter some of their settings on the telephone system. This is done using the **Play Configuration Menu** action.

## Related links

[Adding a Play Configuration Menu Action](#) on page 73

---

## Adding a Play Configuration Menu Action

Through this exercise, you can add an action to enable users to configure their user options via voicemail. It is beneficial when users are working remotely.

The following is an image of a completed call flow:

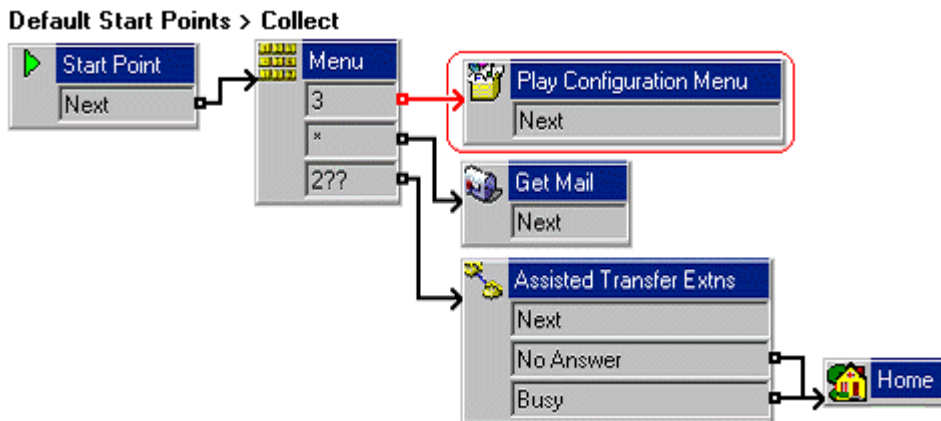

The red arrow or arrows in the call flow are the changes added in this section.

## Procedure

1. Within **Default Start Points > Collect**, add touch-tone **3** to the **Menu** action.
2. From **Configuration Actions**, add a **Play Configuration Menu** action and open its properties.
3. Click the **Save & Make Live** icon.

4. Do the following to test call flow:
  - a. From extension 208, dial \*17.
  - b. Press 3. The configuration list options are announced.
  - c. Press 5 for **Do Not Disturb**.
  - d. Press 1 to enable and end the call.
  - e. Dial extension 208 from any other extension. You will hear a busy tone.
  - f. End the call.
  - g. Repeat the steps and press 3 to disable **Do Not Disturb**.

**Related links**

[Using a Play Configuration Menu Action](#) on page 73

# Chapter 20: Using an Alarm Set Action

The voicemail server can use its own internal clock to provide time related options to callers.

## Related links

[Using the Alarm Set Action](#) on page 75

[Using the Clock Action](#) on page 76

---

## Using the Alarm Set Action

Through this exercise, you can learn to add an **Alarm Set** action to **Default Start Points > Collect** and allow users to set alarm calls on their extensions via voicemail. The **Alarm Set** action can only be used on internal extensions. Voicemail attempts to present the alarm call every 5 minutes for half an hour until answered.

The following is an image of a completed call flow:

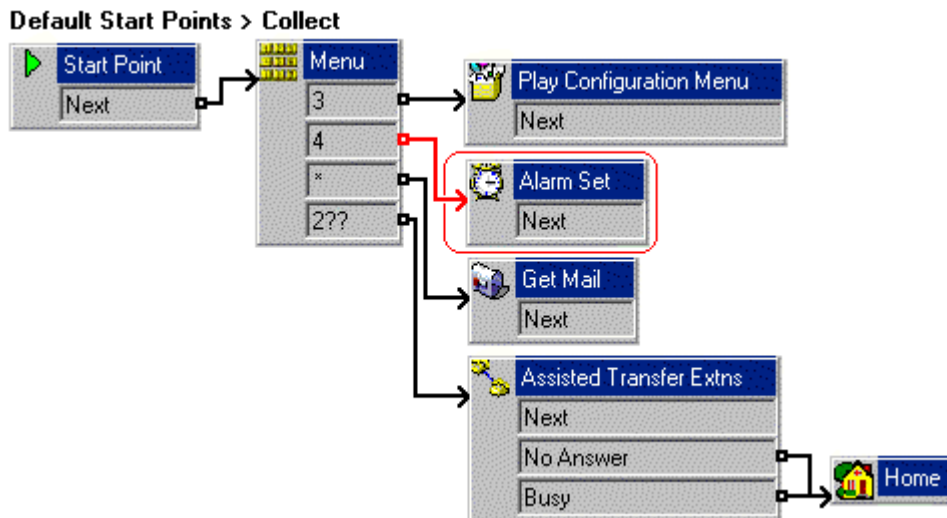

The red arrow or arrows in the call flow are the changes added in this section.

## Procedure

1. In **Default Start Points > Collect**, add touch-tone 4 to the **Menu** action.
2. From the **Miscellaneous Actions** icon, add an **Alarm Set** action.

3. Connect 4 to the **Alarm Set** action.
4. Click the  **Save & Make Live** icon.
5. Do the following to test call flow:
  - a. From any extension, dial \*17 and press 4.
  - b. Follow the instructions and set an alarm call for 3 minutes after the current time on the voicemail server.
  - c. The extension should ring at the time requested. When you answer, you will hear the message recorded when the alarm was set. End all calls.

### Related links

[Using an Alarm Set Action](#) on page 75

---

## Using the Clock Action

Through this exercise, you can add a new module to give users the time from the Voicemail Server PC.

The following is an image of a completed call flow:

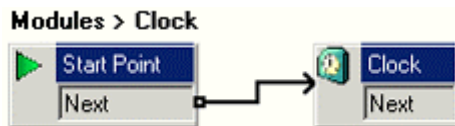

### Procedure

1. Add a new **Modules** called **Clock**.
2. From **Miscellaneous Actions**, add a **Clock** action to the module.
3. Connect the **Start Point** and the **Clock** action.
4. Click the  **Save & Make Live** icon.
5. In IP Office Manager, add the following short codes:
  - a. In **Code**, enter 123.
  - b. In **Feature**, enter Voicemail Collect.
  - c. In **Telephone Number**, enter Clock.
  - d. In **Line Group ID**, enter 0.
6. Save and merge the configuration with the telephone system.
7. Dial 123 on any extension. The time according to the voicemail server is provided.

### Related links

[Using an Alarm Set Action](#) on page 75

[Triggering Actions for Other Users](#) on page 77

## Triggering Actions for Other Users

Having created a callflow to perform some particular action, you may want that callflow presented to another user. This can be done using a **Post Dial** action.

### Related links

[Using the Clock Action](#) on page 76

[Adding a Post Dial Action](#) on page 80

# Chapter 21: Using a Callback Start Point

Through this exercise, you can use a Callback start point to let Bob Rogers (extension 207) be informed of new voicemail messages when at a remote location, for example, his mobile, home number and so on. This feature is separate from voicemail ring back, which works with the user's internal extension number.

Before Bob Rogers can use callback start point, his system administrator must configure a voicemail code for their mailbox.

## Related links

[Setting Up the Callback Call Flow](#) on page 78

[Setting the Callback Number](#) on page 79

---

## Setting Up the Callback Call Flow

The following is an image of a completed call flow:

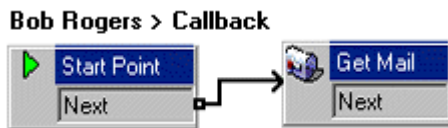

## Procedure

1. Under **Specific Start Points**, right-click **Users** and select **Add**.
2. In **Name**, enter Bob Rogers.
3. Select the **Callback** entry point and select **OK**.
4. Within Bob Rogers, select **Callback**.
5. Add a **Get Mail** action and under the **Specific** tab, in **Mailbox** enter his username or extension.
6. Connect the **Start Point** and the **Get Mail** action.
7. Click the **Save & Make Live** icon.

## Related links

[Using a Callback Start Point](#) on page 78

---

## Setting the Callback Number

Through this exercise, you can enter the number to be called. Through the IP Office Manager configuration.

### Procedure

1. In IP Office Manager, open the **Users** configuration form for Bob Rogers.
2. In the **Voicemail** tab, in **Voicemail Code**, enter 5678 and confirm this in Confirm Voicemail Code.

 **Note:**

The callback does not work if the user does not have a voicemail code set.

3. In the **Source Numbers** tab, add the relevant telephone number prefixed by a capital P.  
For example, P01923123456. For testing this, use a mobile number if your test system has external lines. Otherwise, use an extension number.
4. Save and send the configuration to the telephone system.
5. From any other extension, dial 207 and leave a message for Bob Rogers.

### Result

After a few seconds, the telephone number configured in the Source Numbers tab rings. When answered, you are prompted for the voicemail access code. Once that is entered, you can access the mailbox.

### Related links

[Using a Callback Start Point](#) on page 78

# Chapter 22: Triggering Actions for Other Users

Having created a callflow to perform some particular action, you may want that callflow presented to another user. This can be done using a **Post Dial** action.

## Related links

[Using the Clock Action](#) on page 76

[Adding a Post Dial Action](#) on page 80

---

## Adding a Post Dial Action

The **Post Dial** action can be used to play the actions in a Voicemail Pro start point to a different extension than the one triggering the process.

You can create a short code that allows the **Reception** to play the **Clock** module previously created to another extension. This is just an example of how post dial can be used to launch a chosen call flow start point at another extension (we could have used a Menu action to let the receptionist indicate the extension).

The following is an image of a completed call flow:

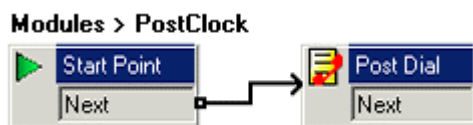

## Procedure

1. Add a new **Modules** called **PostClock**.
2. From **Miscellaneous Actions**, add a **Post Dial** action and open its properties.
  - a. In the **Specific** tab, in **Post** the following action or wav file, click .
  - b. Select **Start Point** or module and select the **Clock** module created previously.
  - c. Click **OK**.
  - d. In to extension, enter 207 and select **OK**.
3. Connect the **Start Point** to the **Post Dial** action.

4. Click the  **Save & Make Live** icon.
5. In IP Office Manager, add the following short codes:
  - a. In **Code**, enter \*98.
  - b. In **Feature**, enter Voicemail Collect.
  - c. In **Telephone Number**, enter Post Clock.
  - d. In **Line Group ID**, enter 0.
6. The **Post Dial** action can also be used to play a wav file to the target extension.

### Example

For example, to play the file `c:\file\mymusic.wav`, in the **Specific** tab, you can to play the .wav file in a continuous loop and delete the .wav file after completion.

### Related links

[Triggering Actions for Other Users](#) on page 77

# Part 5: Using Campaigns

# Chapter 23: Using Campaigns

Through this exercise, you can create a campaign where callers are prompted for information that can be recorded and then accessed by a user when required. The user responsible for responding to the information can listen to the resulting `wav` files.

This exercise recreates the catalog request process previously produced using a Voice Question action. It reuses the `wav` files created for the earlier exercise.

## Related links

[Creating the Campaign](#) on page 83

[Getting Callers to the Campaign \(Part 1\)](#) on page 86

[Getting Callers to the Campaign \(Part 2\)](#) on page 87

[Getting Callers to the Campaign \(Part 3\)](#) on page 87

---

## Creating the Campaign

### Procedure

1. Click the **Campaign Editor** icon.  
The Campaign Wizard Introduction window opens.
2. Select **Create a new Campaign**.
3. Click **Next**.  
The Customer Prompts window opens.
4. In Customer Prompts window, do the following:
  - a. Click **+ Add**.  
The **Please edit the Campaign Action** window opens.
  - b. Select the option **Play a prompt to the customer**.  
A `.wav` file created in the earlier exercises is reuse.
  - c. Click **Browse**.  
The Wave Editor window opens.
  - d. In **Please select a file or enter a new file name**, click  **Open**.

- e. Select `catalogue.wav` and click **Open**.  
You return to the Wave Editor window.
- f. Click **Close**.  
You return to the Please edit the Campaign action, window.
- g. Click **OK**.  
You return to the Customer Prompt window.
- h. Click **+ Add** and in **Play a prompt to the customer** enter `name.wav`.
- i. Click **OK**.  
You return to the Customer Prompt window.
- j. Click **+ Add** and select the **Allow the customer to input information** option.
- k. In **Please enter the maximum recording length**, enter 10.
- l. In **Please enter a unique name that will describe the input**, enter `CustomerName`.

**\* Note:**

When entering a name, ensure that you use no spaces.

- m. Click **OK**.

You return to the Customer Prompt window.

- 5. Repeat the procedure to add `address.wav`, allow 20 seconds recording time, and enter `CustomerAddress` as the unique name.

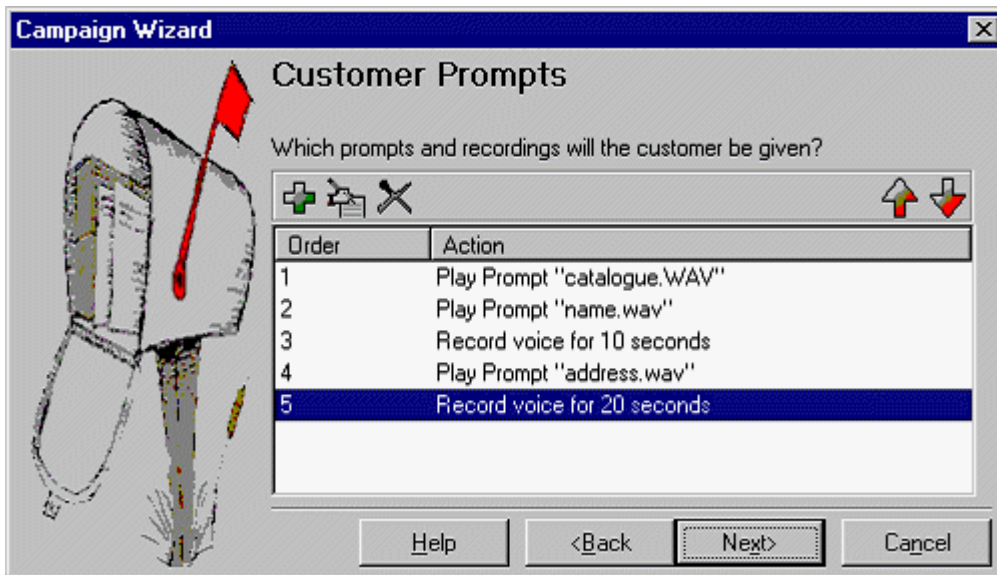

- 6. Click **Next**.

The Customer Menu window opens.

7. Do the following in the Customer Menu window:
  - a. In **Please select the prompt to be played after the customer has made their recordings**, use the  **Browse** to enter the wav file called `thanks.wav`.
  - b. Under **Please select which options will be available to the customer after the above prompt has played**, select **1, 2, 3, and 4**.

**\* Note:**

Ensure the prompt `thanks.wav` recording is recorded with selected options.

- c. Click  **Browse** to open the Wave Editor window and re-record the prompt.

Return to the Customer Menu window.

**Customer Menu**

Please select the prompt to be played after the customer has made their recordings

thanks.wav

Please select which options will be available to the customer after the above prompt has played

Key Press	Action
<input checked="" type="checkbox"/> 1	Save the Campaign (and then quit)
<input checked="" type="checkbox"/> 2	Play back responses to Campaign
<input checked="" type="checkbox"/> 3	Restart the whole Campaign
<input checked="" type="checkbox"/> 4	Quit the Campaign (without saving)

Time out

Wait for a key press for up to  seconds

- d. Click **Next**.

The Campaign Identification window opens.

8. In Campaign Identification, do the following:
  - a. In **Where should this Campaign be parked when information is either left by a customer or collected by an agent?**, enter `5000`.
  - b. In **The name of this Campaign is**, enter **Sales Catalog**.
  - c. Click **Next**.

The A new Campaign called "Sales catalogue" will now be produced window opens.

- d. Click **Finish** to produce the campaign.

## Related links

[Using Campaigns](#) on page 83

---

# Getting Callers to the Campaign (Part 1)

You can add a call flow to test the Catalog campaign.

The following is an image of a completed call flow:



## Procedure

1. Add a new **Modules** called **Catalog**.
2. From **Mailbox Actions**, add a **Campaign** action and open its properties.
  - a. In the **Specific** tab, from the **Please select a campaign** list, select **Sales Catalog**.
  - b. Ensure the **Leave campaign information** option is selected and click **OK**.
3. Connect the **Start Point** to the **Campaign** action.
4. Click the  **Save & Make Live** icon.
5. In IP Office Manager, add the following short codes:
  - a. In **Code**, enter \*94.
  - b. In **Feature**, enter `Voicemail Collect`.
  - c. In **Telephone Number**, enter `Catalogues`.
  - d. In **Line Group ID**, enter 0.
6. Save and merge the configuration with the telephone system.
7. From any extension, dial \*94 and answer the questions as you are taken through the campaign.

Repeat several times to leave several messages for the campaign.

## Related links

[Using Campaigns](#) on page 83

## Getting Callers to the Campaign (Part 2)

You can replace the **Catalog Orders Voice Question** action in the **Attendant** call flow with the **Catalog** module.

The following is an image of a completed call flow:

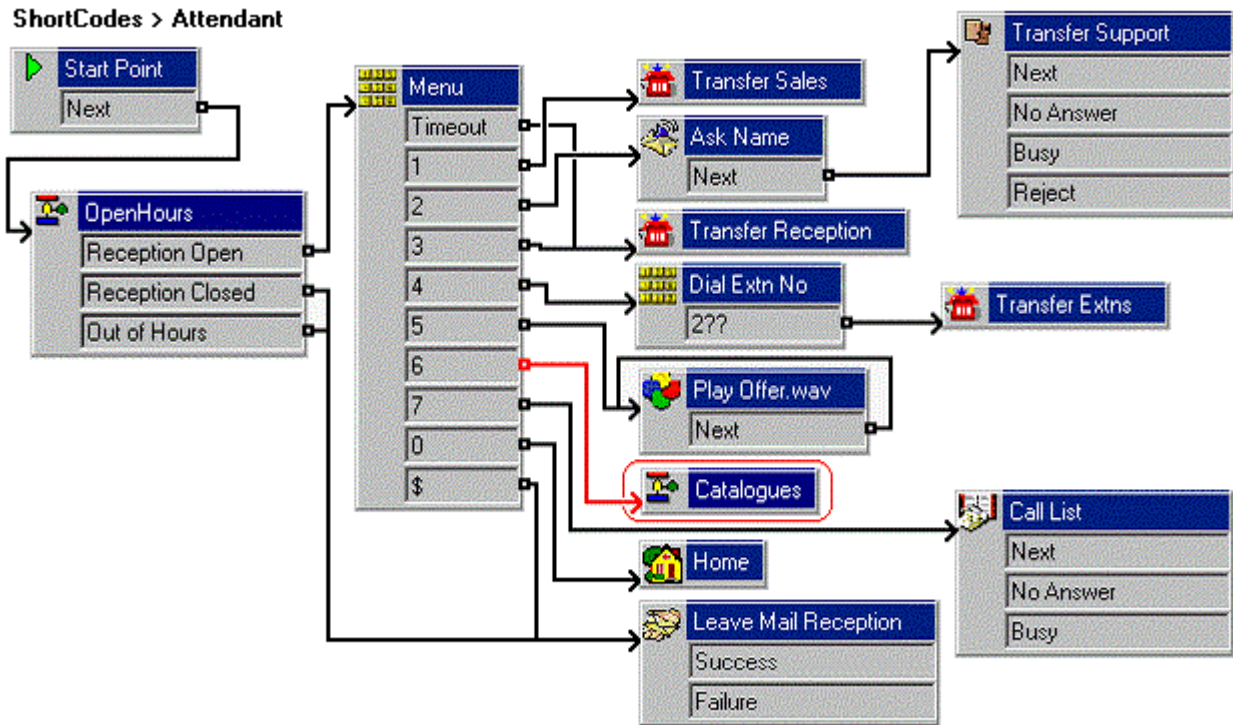

The red arrow or arrows in the call flow are the changes added in this section.

### Procedure

Add an **Incoming Call Route** in IP Office Manager with VM:Catalogues or \*94 as its **Destination**.

### Related links

[Using Campaigns](#) on page 83

## Getting Callers to the Campaign (Part 3)

### Procedure

In IP Office Manager, add the following short codes:

- In **Code**, enter \*96.
- In **Feature**, enter Voicemail Collect.
- In **Telephone Number**, enter Sales Catalogs.

## Using Campaigns

d. In **Line Group ID**, enter 0.

### Related links

[Using Campaigns](#) on page 83

# Chapter 24: Collecting the Campaign Results

After creating a campaign for callers, you must collect and process the results. This can be done in many ways.

**\* Note:**

When you are in the campaign messages, the controls differ from regular mailbox messages. You can step back and forth between the individual responses in the message.

Key	Purpose of the key
1	Start of message
2	Rewind
3	Stop message
4	Mark as processed and delete
5	Mark as processed and save
6	-
7	Previous response
8	Start of response
9	Next response
*	Rewind
0	Pause
#	Fast forward

## Related links

[Using a DSS Key](#) on page 90

[Using the Campaign Action to Collect Messages](#) on page 91

[Using a Short Code to Collect Campaign Messages](#) on page 92

## Using a DSS Key

The Park Slot number assigned to the Campaign can be used with DSS keys. The advantage is that if the key includes a BLF lamp, the lamp is lit when campaign messages are waiting to be processed.

### Procedure

1. In IP Office Manager, receive the telephone system configuration.
2. Open the **Users** form for Kate Smith.
3. To select the **Button Programming** tab.
4. Select a free DSS button, do the following:
  - a. Right-click **Action**.
  - b. Select **Emulation > Call Park**.
  - c. Right-click **Action Data**.
  - d. Enter the park slot number of the campaign.

Enter 5000 for our Catalogue Requests campaign.

5. Save the configuration back to the telephone system and reboot.
6. Wait until voicemail services restarts.

The DSS key on extension 208 flashes red, indicating messages in the campaigns park slot.

7. Press the DSS key to display the campaign name and number of messages.
8. Press the DSS key again to start processing those messages.

#### **Note:**

The UnPark Call function can also be used to collect the calls, but this method does not provide any visual feedback when messages are present.

9. Do the following to use the UnPark Call function:
  - a. Select a free DSS button.
  - b. Right-click **Action**.
  - c. Select **Advanced > Call > UnPark Call**.

### Related links

[Collecting the Campaign Results](#) on page 89



## Using the Campaign Action to Collect Messages

Through this exercise, you can change the call flow for collecting Sales group messages so that users can choose to check the campaign messages.

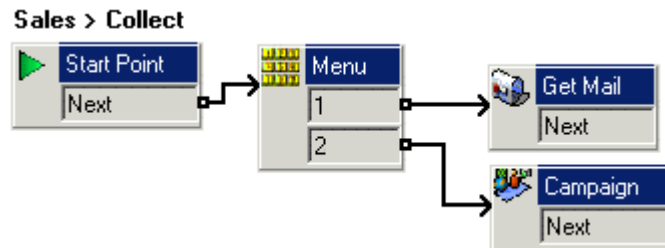
The following is an image of a completed call flow:



### Procedure

1. Record a prompt called `sales collect menu.wav`.  
Record messages as *Press 1 for group messages, 2 for campaign messages*.
2. Under **Groups**, right-click **Sales** and select **Edit**.
3. Add **Collect** to the ticked options and click **OK**.
4. Select the **Collect** start point now under **Sales**.
5. Add a **Menu** action and open its properties.
  - a. In the **Entry Prompts** tab, add `sales collect menu.wav`.
  - b. In the **Touch Tones** tab, select **1** and **2**.
  - c. Click **OK**.
6. Add a **Get Mail** action and open its properties.
  - a. In the **Specific** tab, set the **Mailbox** to **Sales**.
  - b. Click **OK**.
7. Add a **Campaign** action and open its properties.
  - a. In the **Specific** tab, select the **Sales Catalog** campaign and **Pick up campaign information**.
  - b. Click **OK**.
8. Click  **Connection**.
  - a. Select **Start Point** to the **Menu** action.
  - b. Select **1** to select **Get Mail** action.
  - c. Select **2** to select **Campaign** action.
9. Click the  **Save & Make Live** icon.

10. From any extension, dial \*88. Press 2 to collect and process campaign messages.

**Related links**

[Collecting the Campaign Results](#) on page 89

---

## Using a Short Code to Collect Campaign Messages

You can create a short code for direct access to collecting campaign messages.

**Procedure**

1. In IP Office Manager, add the following short codes:
  - a. In **Code**, enter \*98.
  - b. In **Feature**, enter `Voicemail Collect`.
  - c. In **Telephone Number**, enter `Sales Catalog Collect`.
  - d. In **Line Group ID**, enter 0.
2. Save and merge the configuration with the telephone system.
3. At any extension, dial \*98.

You will hear one of the messages left for the **Sales Catalog** campaign.

**Related links**

[Collecting the Campaign Results](#) on page 89

# Part 6: Miscellaneous

# Chapter 25: The NameWavs Table

The NameWavs table is a useful tool for an administrator to record names for mailboxes without having to directly access each mailbox. Through this exercise, you can access the NameWavs table. This is a quick way to access a list of mailboxes without the dialing into each mailbox.

## Related links

[Amending the Recordings Module](#) on page 94

[Recording Names to be used with a Call List Action](#) on page 95

---

## Amending the Recordings Module

You can create and add an action that goes to the NameWavs table for recording individual mailbox names.

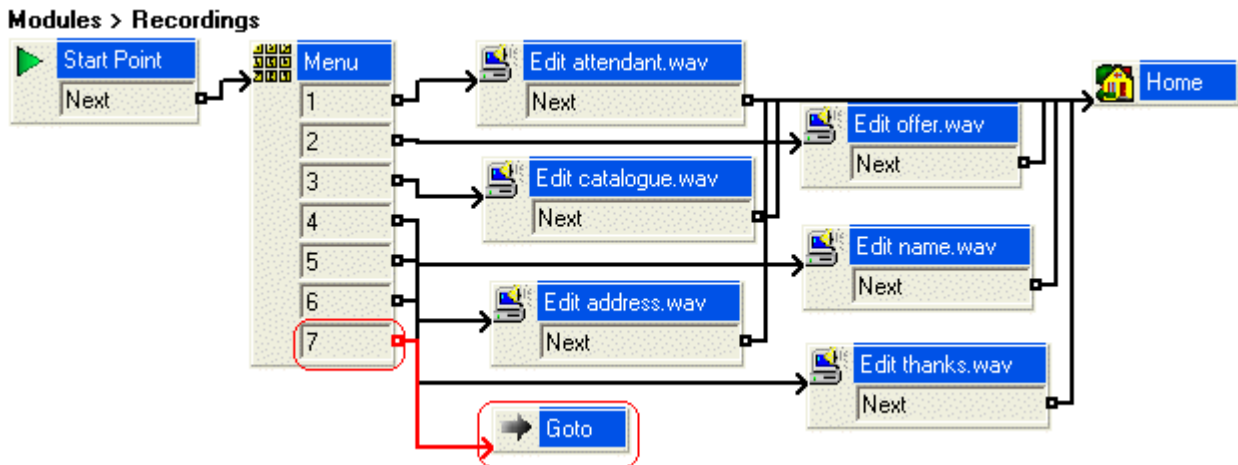

The following is an image of a completed call flow:



The red arrow or arrows in the call flow are the changes added in this section.

## Procedure

1. To add a new option to the **Menu** do the following:
  - a. Select the module **AutoAttend**.
  - b. Open properties for the **Menu** action.

- c. In the **Touch Tones** tab, click **7** and click **OK**.
2. To add a **Goto** action, do the following:
  - a. Click the **Basic Actions** icon, select **Goto**.
  - b. Click the **Details** pane to place the action.
  - c. Right-click the **Goto** action and select **Properties**.
  - d. Click the **Specific** tab.
  - e. In **Please select a node to go to** type `NameWavsTable`.  
You can record mailbox names without going into individual mailboxes.
  - f. Click **OK**.
3. Click  **Connection**.  
Connect **7** to the **Goto** action.
4. Click the  **Save & Make Live** icon.

#### Related links

[The NameWavs Table](#) on page 94

---

## Recording Names to be used with a Call List Action

You can record a name for each extension that is a member of the Accounts group. Through this exercise, you can use names with the Call List Action created above.

If the Voicemail Pro is running Intuity mailbox mode, mailbox users are asked to record their name when they first access their mailbox. They can also re-record their name through the mailbox controls. For IP Office mode mailbox users, you must create a module that uses the **Record Name** action to let users record their name.

### Procedure

1. On any extension, dial \*80.
2. Dial 1234 when requested to enter the access code.
3. Select 1.
4. When prompted, dial 207 and record a name to be associated with that extension, for example: Bob Rogers.
5. When prompted, dial 208 and record a name to be associated with that extension, for example: Kate Smith.
6. Hang-up the call.

7. Make a test call to the auto-attendant module.
  - a. Dial 7 to access the Call List action. You are played the names recorded above together with the associated extension numbers.
  - b. Dial the extension that you want.

**Related links**

[The NameWavs Table](#) on page 94

# Part 7: Further Help

# Chapter 26: Additional Help and Documentation

The following pages provide sources for additional help.

## Related links

- [Additional Manuals and User Guides](#) on page 98
- [Getting Help](#) on page 98
- [Finding an Avaya Business Partner](#) on page 99
- [Additional IP Office resources](#) on page 99
- [Training](#) on page 100

---

## Additional Manuals and User Guides

The [Avaya Documentation Center](#) website contains user guides and manuals for Avaya products including IP Office.

- For a listing of the current IP Office manuals and user guides, look at the [Avaya IP Office™ Platform Manuals and User Guides](#) document.
- The [Avaya IP Office Knowledgebase](#) and [Avaya Support](#) websites also provide access to the IP Office technical manuals and users guides.
  - Note that where possible these sites redirect users to the version of the document hosted by the [Avaya Documentation Center](#).

For other types of documents and other resources, visit the various Avaya websites (see [Additional IP Office resources](#) on page 99).

## Related links

- [Additional Help and Documentation](#) on page 98

---

## Getting Help

Avaya sells IP Office through accredited business partners. Those business partners provide direct support to their customers and can escalate issues to Avaya when necessary.

If your IP Office system currently does not have an Avaya business partner providing support and maintenance for it, you can use the Avaya Partner Locator tool to find a business partner. See [Finding an Avaya Business Partner](#) on page 99.

#### Related links

[Additional Help and Documentation](#) on page 98

---

## Finding an Avaya Business Partner

If your IP Office system currently does not have an Avaya business partner providing support and maintenance for it, you can use the Avaya Partner Locator tool to find a business partner.

#### Procedure

1. Using a browser, go to the [Avaya Website](#) at <https://www.avaya.com>
2. Select **Partners** and then **Find a Partner**.
3. Enter your location information.
4. For IP Office business partners, using the **Filter**, select **Small/Medium Business**.

#### Related links

[Additional Help and Documentation](#) on page 98

---

## Additional IP Office resources

In addition to the documentation website (see [Additional Manuals and User Guides](#) on page 98), there are a range of website that provide information about Avaya products and services including IP Office.

- [Avaya Website](#) (<https://www.avaya.com>)

This is the official Avaya website. The front page also provides access to individual Avaya websites for different regions and countries.

- [Avaya Sales & Partner Portal](#) (<https://sales.avaya.com>)

This is the official website for all Avaya business partners. The site requires registration for a user name and password. Once accessed, you can customize the portal to show specific products and information type that you want to see.

- [Avaya IP Office Knowledgebase](#) (<https://ipofficekb.avaya.com>)

This site provides access to an online, regularly updated version of IP Office user guides and technical manual.

- [Avaya Support](#) (<https://support.avaya.com>)

This site provide access to Avaya product software, documentation and other services for Avaya product installers and maintainers.

- [Avaya Support Forums](https://support.avaya.com/forums/index.php) (<https://support.avaya.com/forums/index.php>)

This site provides forums for discussing product issues.

- [International Avaya User Group](https://www.iuag.org) (<https://www.iuag.org>)

This is the organization for Avaya customers. It provides discussion groups and forums.

- [Avaya DevConnect](https://www.devconnectprogram.com/) (<https://www.devconnectprogram.com/>)

This site provides details on APIs and SDKs for Avaya products, including IP Office. The site also provides application notes for third-party non-Avaya products that interoperate with IP Office using those APIs and SDKs.

- [Avaya Learning](https://www.avaya-learning.com/) (<https://www.avaya-learning.com/>)

This site provides access to training courses and accreditation programs for Avaya products.

#### Related links

[Additional Help and Documentation](#) on page 98

---

## Training

Avaya training and credentials ensure our Business Partners have the capabilities and skills to successfully sell, implement, and support Avaya solutions and exceed customer expectations. The following credentials are available:

- Avaya Certified Sales Specialist (APSS)
- Avaya Implementation Professional Specialist (AIPS)
- Avaya Certified Support Specialist (ACSS)

Credential maps are available on the [Avaya Learning](#) website.

#### Related links

[Additional Help and Documentation](#) on page 98

# Index

## Special Characters

? Wild Card .....	<a href="#">19</a>
\$ Wild Card .....	<a href="#">21</a>

## A

Access Code .....	<a href="#">33</a>
Action	
Alarm Set Action .....	<a href="#">75</a>
Assisted Transfer .....	<a href="#">70</a>
Call List .....	<a href="#">37</a>
Generic .....	<a href="#">22</a>
Home .....	<a href="#">24</a>
Leave Mail .....	<a href="#">43</a>
Module Return .....	<a href="#">52</a>
Play Configuration Menu .....	<a href="#">73</a>
Post Dial Action .....	<a href="#">80</a>
Queue ETA Action .....	<a href="#">61</a>
Set User Variable .....	<a href="#">46</a>
Test Condition .....	<a href="#">41</a>
Test User Variable .....	<a href="#">48</a>
Voice Question .....	<a href="#">27</a>
Whisper Action .....	<a href="#">34, 35</a>
Add	
Module .....	<a href="#">10</a>
Short Code .....	<a href="#">12</a>
adding	
queue eta action .....	<a href="#">60</a>
short code .....	<a href="#">65</a>
Administrator .....	<a href="#">98</a>
Alarm Set Action .....	<a href="#">75</a>
Announcements .....	<a href="#">14</a>
APIs .....	<a href="#">99</a>
Application Notes .....	<a href="#">99</a>
Assisted Transfer Action .....	<a href="#">70</a>

## B

business partner locator .....	<a href="#">99</a>
--------------------------------	--------------------

## C

Call List Action .....	<a href="#">37</a>
Callflow	
Restart .....	<a href="#">24</a>
Clock Action .....	<a href="#">75</a>
collecting	
campaign results .....	<a href="#">89</a>
group messages .....	<a href="#">32</a>
Condition	
Test .....	<a href="#">41</a>

courses .....	<a href="#">99</a>
Create	
Variable .....	<a href="#">46</a>
creating	
attendant hours condition .....	<a href="#">41</a>
campaigns .....	<a href="#">83</a>
new module .....	<a href="#">10</a>

## D

Default Start Point .....	<a href="#">68</a>
---------------------------	--------------------

## E

Entry Prompts .....	<a href="#">14</a>
---------------------	--------------------

## F

forums .....	<a href="#">99</a>
forwarding	
messages to multiple users .....	<a href="#">64</a>

## G

Generic Action .....	<a href="#">22</a>
getting callers	
campaign part 1 .....	<a href="#">86</a>
campaign part 3 .....	<a href="#">87</a>
Group	
Auto Attendant .....	<a href="#">56</a>
Message Waiting Indication .....	<a href="#">32</a>
Remote Access Code .....	<a href="#">33</a>

## H

Help .....	<a href="#">98</a>
Home Action .....	<a href="#">24</a>

## I

Import example exercises .....	<a href="#">7</a>
--------------------------------	-------------------

## L

Leave Mail Action .....	<a href="#">43</a>
-------------------------	--------------------

## M

Manuals .....	<a href="#">98</a>
Menu Action	
Timeout .....	<a href="#">18</a>

Message Waiting Indication .....	<a href="#">32</a>	<b>T</b>	Technical Bulletins .....	<a href="#">99</a>
Module			Test Condition Action .....	<a href="#">41</a>
Add .....	<a href="#">10</a>		Test User Variable Action .....	<a href="#">48</a>
Recording .....	<a href="#">15</a>		Timeout .....	<a href="#">18</a>
Module Return Action .....	<a href="#">52</a>		training .....	<a href="#">99, 100</a>
module returns				
reusing modules .....	<a href="#">51</a>			
<b>N</b>		<b>U</b>		
name		User Guides .....	<a href="#">98</a>	
wav table .....	<a href="#">94</a>	using		
<b>P</b>		assisted transfer action .....	<a href="#">70</a>	
Play Configuration Menu .....	<a href="#">73</a>	callback start point .....	<a href="#">78</a>	
Play Configuration Menu Action .....	<a href="#">73</a>	campaigns .....	<a href="#">83</a>	
Post Dial Action .....	<a href="#">77, 80</a>	clock action .....	<a href="#">76</a>	
Postal Dial Action .....	<a href="#">80</a>	condition editor .....	<a href="#">40</a>	
Prompts .....	<a href="#">14</a>	DSS key .....	<a href="#">90</a>	
		queue position action .....	<a href="#">58</a>	
		user defined variables .....	<a href="#">45</a>	
		<b>V</b>		
<b>Q</b>		Variable		
Queue ETA Action .....	<a href="#">61</a>	Set User Variable Action .....	<a href="#">46</a>	
Quick Reference Guides .....	<a href="#">98</a>	Voice Question Action .....	<a href="#">27</a>	
<b>R</b>		<b>W</b>		
Record		websites .....	<a href="#">99</a>	
Prompts .....	<a href="#">14</a>	Whisper Action .....	<a href="#">34, 35</a>	
recording		Wildcards		
call list action .....	<a href="#">95</a>	? Wild Card .....	<a href="#">19</a>	
names .....	<a href="#">95</a>	\$ Wild Card .....	<a href="#">21</a>	
sales still queued message .....	<a href="#">62</a>			
Remote Access Code .....	<a href="#">33</a>			
Reseller .....	<a href="#">98</a>			
<b>S</b>				
sales .....	<a href="#">99</a>			
SDKs .....	<a href="#">99</a>			
Set User Variable Action .....	<a href="#">46</a>			
setting				
callback number .....	<a href="#">79</a>			
Short Code				
Add .....	<a href="#">12</a>			
Start Point				
Callback .....	<a href="#">78</a>			
Default Start Point .....	<a href="#">68</a>			
still				
queued .....	<a href="#">62</a>			
support .....	<a href="#">99</a>			
system				
configuration .....	<a href="#">6</a>			
System Administrator .....	<a href="#">98</a>			